



National Fire Protection Association

1 Batterymarch Park, Quincy, MA 02169-7471
Phone: 617-770-3000 • Fax: 617-770-0700 • www.nfpa.org

MEMORANDUM

TO: NFPA Technical Committee on Respiratory Protection Equipment

FROM: Stacey Van Zandt

DATE: August 15, 2011

SUBJECT: NFPA 1981 ROP TC Letter Ballot (F2012)

The ROP letter ballot for NFPA 1981 is attached. The ballot is for formally voting on whether or not you concur with the committee's actions on the proposals. Reasons must accompany all negative and abstention ballots.

Please do not vote negatively because of editorial errors. However, please bring such errors to my attention for action.

Please complete and return your ballot as soon as possible but no later than August 30, 2011. As noted on the ballot form, please return the ballot to Stacey Van Zandt either via e-mail to svanzandt@nfpa.org or via fax to 617-984-7056. You may also mail your ballot to the attention of Stacey Van Zandt at NFPA, 1 Batterymarch Park, Quincy, MA 02169.

The return of ballots is required by the Regulations Governing Committee Projects.

Attachments: Proposals
Letter Ballot

1981-1 Log #1 FAE-RPE
(Entire Document)

Final Action: Reject

Note: This Proposal appeared as Comment 1981-33 (Log #5) which was held from the F2006 ROC on Proposal 1981-1.

Submitter: Tom Kissner, Smithsburg, MD

Recommendation: Instead of changing the cylinders, why don't you just change the bracket that holds the cylinder? Make all of the manufactures can to a ratchet type assembly. Have NIOSH and OSHA lift there cylinder requirement by the same manufacture to gain there certification for use.

Substantiation: Agree, but with changes.

Committee Meeting Action: Reject

Committee Statement: The technical committee rejected this proposal because it is outside the scope of the standard. This is an apparatus design issue.

1981-2 Log #2 FAE-RPE
(Entire Document)

Final Action: Reject

Note: This Proposal appeared as Comment 1981-5 (Log #14) which was held from the F2006 ROC on Proposal 1981-2.

Submitter: David Covington, San Antonio Fire Department

Recommendation: It is my understanding that the committee is working on cylinder interoperability compatibility. Although this may be a good idea, I caution the committee to consider it very carefully in light of recent events in San Antonio. We recently experienced a number of o-ring failures where the SCBA valve screws in to the cylinder. After sending units to NIOSH and Southwest Research Institute (a respected research lab in San Antonio), we have found that the type of fitting that we now use in our SCBA cylinders is antiquated and based on a 1965 CGA standard.

Substantiation: The engineers at SWRI have concluded that the design is flawed and this would explain our o-ring failures. Our informal poll of departments confirmed that virtually all SCBA manufacturers have o-ring issues. The CGA spec does not include an o-ring but allows it when hand tightening. We have more information if you wish to see it, but the real issue is that it would be wrong to build an interoperability based on a defective design that has plagued the fire service for many years. The correct method would be to consult the dive people who have ditched the design and work out a new fitting that works for firefighters.

Committee Meeting Action: Reject

Committee Statement: NIOSH is the federal agency that writes standards for respiratory protection. The CGA fitting specified in 42 CFR Part 84 meets the performance requirements of the current NIOSH and NFPA standards. Since the federal standards incorporated the CGA fitting for cylinder filling in 1972, many hundreds of approvals have been processed. There have been very few complaints relative to the CGA connector, and there is no body of evidence indicating the current CGA standard is inherently flawed. Furthermore, CGA would be the appropriate body to modify this standard. NIOSH uses industry and consensus standards wherever possible. NIOSH does not prohibit the manufacturer from employing other types of connectors in addition to the CGA-compatible connectors. Several SCBA manufacturers incorporate an additional fitting.

1981-3 Log #3 FAE-RPE
(Entire Document)

Final Action: Reject

Note: This Proposal appeared as Comment 1981-10 (Log #88) which was held from the F2006 ROC on Proposal 1981-2.

Submitter: I. David Daniels, International Association of Fire Chiefs

Recommendation: The Safety, Health and Survival section of the IAFC is in favor of changes to SCBAs that provide for interoperability. To this end, we believe that the most effective approach would be to require the retroactive installation of a standardized RIC/RIT connection, in addition to requiring that all new assemblies be provided with the connection. We agree that work needs to be done on cylinder standardization, but do not feel it reasonable to expect that this would occur in a reasonable period of time, given the technical financial and legislative changes that will be necessary to accomplish this.

Substantiation: The problem with cylinder standardization in the standard is the reality that many agencies will not be able to comply with the requirement in the short term principally for financial reasons. Fire Departments continue to struggle with shrinking budgets; therefore, it does not seem like a good idea to create a requirement that few will strive to achieve due to perceptions barriers, when the same objective can be achieved by alternative means. Further, a requirement in the standard for standardization of cylinders may create a greater safety hazard in its place if organizations elect to ignore it.

Committee Meeting Action: Reject

Committee Statement: An RIC UAC connection is a required component on all SCBA certified to the 2002 and 2007 Editions of NFPA 1981. Design and performance requirements cannot be added to past editions of NFPA 1981.

However, replacement parts, components and add-on accessories are permitted, as explained in paragraphs 4.2.8.1 and 4.2.8.2 of NFPA 1981, 2007 Edition. An SCBA upgrade to the 2007 Edition of NFPA 1981 is permitted under the conditions specified in NFPA 1852, *Standard on Selection, Care, and Maintenance of Open-Circuit Self-Contained Breathing Apparatus (SCBA)*, 2008 Edition.

1981-4 Log #4 FAE-RPE
(Entire Document)

Final Action: Reject

Note: This Proposal appeared as Comment 1981-26 (Log #245) which was held from the F2006 ROC on Proposal 1981-2.

Submitter: Roger Donnellan, Waynesville, NC

Recommendation: Every new SCBA purchased has a RIT fitting at the cylinder valve. This RIT fitting is universal on all new SCBA no matter the manufacturer. The new NFPA update on SCBA proposed enhanced communications and CBRN, both of these proposed upgrades are long overdue. You should also include a self rescue on SCBA's harness, when all other avenues are closed.

I suggest removal of all 2,200 psi and 3,000 psi SCBA's cylinders and upgrade to 4,500 psi 1,200, 1800 and 2400 liters. All cylinder valve outlets should be on the same side.

Substantiation: I disagree that there will be no more innovations on SCBA's.

Committee Meeting Action: Reject

Committee Statement: NFPA 1981 deals with respiratory protection, not with rescue harnesses. Self-rescue devices are commercially available, and NFPA 1981 does not preclude their use as an accessory in conjunction with an SCBA. The proposer provides no substantiation, so it is difficult to address the portion of the proposal dealing with cylinder pressure. Cylinder pressure does not determine cylinder volume. Limiting pressure would be design-restrictive, and the TC sees no benefit in eliminating pressure options. Again, the proposer provides no substantiation for the portion of the proposal dealing with cylinder valve outlets. There is not enough information provided to determine the need, and the technical committee is rejecting this proposal because it is design-restrictive.

1981-5 Log #5 FAE-RPE
(Entire Document)

Final Action: Reject

Note: This Proposal appeared as Comment 1981-31 (Log #31) which was held from the F2006 ROC on Proposal 1981-2.

Submitter: Tom May, Rochester, NY

Recommendation: I would like to comment on the SCBA Standard 1981.

The heads up display is a good idea to remind wearers of their air supply, but I have found problems. In very dark conditions the bright lights opposes one's night vision. While searching for both life and fire I find the heads up display very distracting, and I feel more blind than usual.

My suggestion is to try using all red lights to allow better night vision, or just one red light that comes on at 1/2 the bottles capacity.

Substantiation: The current heads up display could cause as many problems as it solves. I can imagine that some one could miss the signs of rollover, or miss finding a fire when the glow of a fire is not seen due to that blinding green light in one's face.

I have heard the same comments from other firefighters, but no one seems to know how to make changes. I assume this is a start. I have also heard that NFPA codes are mainly developed by industry and those who do not use the firefighting equipment. I hope that the firefighters who use the equipment are listened to.

Committee Meeting Action: Reject

Committee Statement: The HUD is required to display a signal in at least four increments of pressure to represent the function of a gauge. A single light at 50% would not fulfill this requirement. There is no evidence to suggest that a change to all red lights would improve any issues with glare. Also, there is no concrete evidence indicating one color is less obtrusive than another when utilized in a Heads-Up-Display. In relation to night-blindness, there are compelling arguments both for and against the use of the color red. Additionally, other research has shown the blue/greens and yellow/greens would be preferable. Since there is no definitive evidence that would warrant a HUD light-color mandate, the technical committee rejected the proposal.

1981-6 Log #10 FAE-RPE
(Entire Document)

Final Action: Accept in Principle

Submitter: Jeffrey O. Stull, International Personnel Protection, Inc.

Recommendation: Develop criteria for alternative pressure vessel technology incorporated into SCBA.

Substantiation: Consideration should be provided in the revision of NFPA 1981 to alternative pressure vessels. One such pressure vessel technology based on an array of multiple non-metal lined pressures should be used as a model for the development of new criteria that anticipate alternative pressure vessel implications for design and performance criteria provided in NFPA 1981. A project team lead by the IAFF will be willing to propose specific criteria for the committee's consideration.

Committee Meeting Action: Accept in Principle

See meeting action on 1981-26 (Log #CP7).

Committee Statement: NFPA 1981 does not preclude alternative pressure vessel technology to be incorporated into SCBA. However, should a specific alternative pressure vessel be developed and certified that cannot be tested to existing NFPA 1981 test methods, the technical committee will develop or modify test methods that would accommodate such technology. See also 1981-26 (Log #CP7).

1981-7 Log #CP1 FAE-RPE
(Entire Document)

Final Action: Accept

Submitter: Technical Committee on Respiratory Protection Equipment,

Recommendation: Review entire document to: 1) Update any extracted material by preparing separate proposals to do so, and 2) review and update references to other organizations documents, by preparing proposal(s) as required.

Substantiation: To conform to the NFPA Regulations Governing Committee Projects.

Committee Meeting Action: **Accept**

Committee Statement: The technical committee reviewed the entire document to update any extracted material, and reviewed and update references to other organizations documents. Separate proposals were prepared as required.

1981-8 Log #CP4 FAE-RPE
(Chapters 1, 3, 6, 7, 8)

Final Action: Accept

Submitter: Technical Committee on Respiratory Protection Equipment,

Recommendation: Add a new paragraph 1.3.1.1 as follows:

1.3.1.1 If the SCBA is equipped with an EBSS, the EBSS performance requirements set forth in this standard shall only apply to open-circuit SCBA and combination SCBA/SARs used by the fire service for respiratory protection of its personnel during the applications listed in 1.3.1.

Revise text as follows:

3.3.X EBSS Abbreviation for emergency breathing safety system.

3.3.X Emergency Breathing Safety System (EBSS). A device on an SCBA that allows users to share their available air supply in an emergency situation.

Insert Table 4.3.9 Here

5.2.6 (5) Emergency procedures to be followed in the event of an out-of-air situation.

6.6 Emergency Breathing Safety System (EBSS) Design Requirements

6.6.1 If an SCBA is equipped with an EBSS, it shall meet the performance requirements of 7.20 and 8.27.

6.6.2 Each EBSS shall operate off the pressure after the first stage pressure reducer of the SCBA.

6.6.3 The EBSS shall have an operating pressure of at least 5.5 bar (80 psi).

6.6.4 The EBSS shall have a male and female connection with a check valve feature to prevent inward contaminants.

6.6.5 The EBSS pressure hose assembly shall be a minimum of 20" long.

6.6.6 The EBSS shall be accessible by the wearer.

6.6.7 The EBSS shall require only one action for connection of the donor's fitting to the receiving SCBA's fitting.

6.6.8 The EBSS shall require two distinctive actions to disconnect the fitting between the donor SCBA and receiving SCBA.

6.6.9 The EBSS fitting(s) shall be equipped with a dust cap or sealing plug to prevent dust, dirt, and debris from entering the fitting(s).

6.6.10 The connection of two EBSS shall be independent of the facepieces.

7.20 Emergency Breathing Safety System Cold Temperature Performance Requirements

7.20.1 Each SCBA shall be tested independently for airflow performance as specified in Section 8.1, Airflow Performance Test, and the SCBA facepiece pressure shall not be less than 0.0 mm (0.0 in.) water column and shall not be greater than 89 mm (3½ in.) water column above ambient pressure from the time the test begins until the time the test is concluded.

7.20.2 Each SCBA shall be tested independently for activation of EOSTI during the airflow performance testing specified in Section 8.1, Airflow Performance Test, and each EOSTI shall activate as specified in 6.2.2 and shall continue to operate throughout the remainder of the airflow performance test.

7.20.3 Each SCBA shall be tested independently for proper functioning of the HUD breathing air cylinder content informational display and visual alert signals during the airflow performance testing specified in Section 8.1, Airflow Performance Test, and the HUD shall display the visual information for the breathing air cylinder content as specified in 6.3.9.5 and shall display the visual alert signal as specified in 6.3.8.5.

7.20.4 The SCBA classified as the donor shall start at full cylinder pressure and the SCBA classified as the receiving SCBA shall have a pressure of 7 bar + 0.6 bar/- 0 bar (100 psi + 10 psi/- 0).

7.20.5 Both SCBA shall be connected through the EBSS and shall be tested for cold environment as specified in 8.X and the SCBA facepiece pressure shall not be less than 0.0 mm (0.0 in.) water column and shall not be greater than 89 mm (3½ in.) water column above ambient pressure from the time the test begins until the time the test is concluded.

7.20.6 The donor SCBA shall be tested for activation of EOSTI during the environmental temperature performance as specified in Section 8.X, Emergency Breathing System Cold Temperature Performance Test.

7.20.7 The donor SCBA shall be tested for the proper functioning of the HUD breathing air cylinder content informational display and the visual alert signal during the environmental temperature performance as specified in Section 8.X, Emergency Breathing System Cold Temperature Performance Test.

8.27 Emergency Breathing Safety System Cold Temperature Performance Test

8.27.1 Application. This test method shall apply to two complete SCBA.

8.27.2 Samples. Each sample to be tested shall be as specified in 4.3.9.

Table 4.3.9 Test Series

Test Order	Category A (SCBA #1)	Category B (SCBA #2)	Category C		Category D		Category E (SCBA #5)	Category F (SCBA #6)	Category G (Component Tests)	Category H (Additional SCBA as required)
			(SCBA #3)	(SCBA #4)	(SCBA #3)	(SCBA #4)				
1	Airflow (Section 8.1)	Airflow (Section 8.1)	Airflow (Section 8.1)	Airflow (Section 8.1)	HUD visibility performance (Sections 8.17 through 8.19)	Low power capacity test (Section 8.26)	Fabric flame resistance (Section 8.4)	EOSTI independent activation (Section 8.13)		
2	Facepiece carbon dioxide content (Section 8.12)	Breathing air cylinder and valve assembly retention test (Section 8.22)	Vibration resistance (Section 8.3)	Heat and flame resistance (Section 8.11)	HUD low power source visual alert signal test (Section 8.16)	Heat and immersion leakage tests (Section 8.24)	Fabric heat resistance (Section 8.5)	EOSTI recognition performance (Section 8.14)		
3	Mechanical voice diaphragm test (Section 8.10)	Cylinder connections and accessibility test (Section 8.23)	—	—	Wiring connection performance (Section 8.15)	—	Thread heat resistance (Section 8.6)	<u>Lens Convection</u> (Section 8.29)		
4	Voice communications system test (Section 8.25)	RIC UAC cylinder refill breathing performance (Section 8.20)	—	—	<u>Lens Radiant Heat</u> (Section 8.28)	—	Facepiece lens abrasion resistance (Section 8.9)	—		
5	Environmental temperature (Section 8.2)	RIC UAC system fill rate performance (Section 8.21)	—	—	—	—	—	—		
6	Particulate resistance (Section 8.8)	Accelerated corrosion resistance (Section 8.7)	—	—	—	—	—	—		
	<u>EBSS Cold Temp. Performance Test (+)</u> (Section 8.27)	<u>EBSS Cold Temp. Performance Test (+)</u> (Section 8.27)	—	—	—	—	—	—		
7	<u>Particulate resistance</u> (Section 8.8)	<u>Accelerated corrosion resistance</u> (Section 8.7)	—	—	—	—	—	—		

+ to be tested together

8.27.3 Specimen Preparation.

8.27.3.1 Specimens for conditioning shall be two complete SCBA.

8.27.3.2 Prior to testing, the SCBA shall be placed in an ambient environment of 22°C, ± 3°C (72°F, ±5°F) and RH of 50 percent, ±25 percent for a minimum 12-hour dwell period.

8.27.3.3 The air used in the SCBA breathing air cylinders shall comply with the quality requirements of NFPA 1989, *Standard on Breathing Air Quality for Fire and Emergency Services Respiratory Protection*.

8.27.4 Apparatus.

8.27.4.1 The SCBA shall be placed in an environmental chamber and positioned to simulate the normal wearing position of the SCBA on a person as specified by the manufacturer.

8.27.4.2 During the cold temperature exposures the SCBA shall be mounted on a Scott Aviation Model No. 803608-01 or 803608-02 test head form or equivalent.

8.27.4.3 The thermocouple or other temperature-sensing element used shall be mounted within the chamber in a manner in which it will be exposed directly to the chamber atmosphere.

8.27.4.4 Two test head forms shall be connected to two breathing machines specified in Section 8.1, Airflow Performance Test.

8.27.4.5 The breathing machines shall be permitted to be located either inside or outside the environmental chamber.

8.27.5 Procedure.

8.27.5.1 The variation in pressure extremes caused by the cold temperature performance test configuration shall be determined in the following manner. The airflow performance test as specified in Section 8.1, Airflow Performance Test, shall be carried out using the configuration specified in 8.2.4 at the 103 L/min, ±3 L/min ventilation rate. The difference in pressure between the two tests shall be calculated by subtracting the values obtained using the configuration defined in 8.2.4 from the values obtained using the configuration specified in Section 8.1, Airflow Performance Test.

8.27.5.1.1 The breathing machine for the donor SCBA and for the receiving SCBA shall be such that they initially operate out of phase of each other. At least twice during the test duration the breathing machines must operate in phase with each other.

8.27.5.2 The facepiece pressure during each entire test shall be read from the strip chart recorder and corrected by adding the value of the difference in pressure calculated in 8.2.5.1 to determine pass or fail as specified in 7.2.1.1.

8.27.5.3 The dwell period between cold temperature tests shall be used for refilling the breathing air cylinder and visually inspecting the SCBA for any gross damage that could cause unsafe test conditions.

8.27.5.4 The SCBA shall be cold soaked at -32°C, ±1°C (-25°F, ±2°F) for a minimum of 12 hours.

8.27.5.5 The SCBA shall then be tested for airflow performance as specified in Section 8.1, Airflow Performance Test, at a chamber air temperature of -32°C, ±5°C (-25°F, ±10°F).

8.27.5.5.1 For the EBSS cold temperature performance test the airflow performance test shall begin after five cycles of the breathing machine and shall continue to operate through at least 36 bar (520 psi) of cylinder inlet pressure.

8.27.6 Report.

8.27.6.1 The facepiece peak inhalation pressure and peak exhalation pressure shall be recorded and reported for each test condition.

8.27.6.2 The activation and operation or the failure to activate and operate of the donor SCBA EOSTI shall be recorded and reported.

8.27.6.3 The activation and identification of the donor SCBA HUD visual alert signals shall be recorded and reported.

8.27.7 Interpretation.

8.27.7.1 The peak inhalation and peak exhalation shall be used to determine pass or fail performance for each test procedure.

8.27.7.2 One or more specimens failing this test shall constitute failing performance.

8.27.7.3 Failure of the donor SCBA EOSTI alarm signal to activate and remain active during the test shall constitute failing performance.

8.27.7.4 Failure of the donor SCBA HUD to display the breathing air cylinder content or to display the visual alert signal during the test shall constitute failing performance.

Substantiation: EBSS have advanced technologically over the years and, with proper training, can increase user safety in emergency scenarios. At the ROP meeting in July 2011, the technical committee was informed by NIOSH representatives that NIOSH is expected to change its policy regarding the use of EBSS via the issuance of a policy amendment in August 2011. It is anticipated that NIOSH will rescind its former prohibition of EBSS for fire fighting, and will allow certification and use of EBSS for that application only. The technical committee believes that, since EBSS will soon become a permissible optional component of an SCBA, NFPA 1981 should include the minimum EBSS performance requirements.

Committee Meeting Action: Accept

1981-9 Log #8 FAE-RPE
(1.6)

Final Action: Reject

Submitter: Suleiman Said Al Adawi, Petroleum Development Oman

Recommendation: The standard should specify the spare self contained breathing apparatus cylinders proportionate to the number of breathing apparatus sets based on decided numbers of BA sets in fire stations. For instance 1 BA set should have 1 spare cylinder.

NOTE: I tried to read different standards and seek/exchange ideas with my colleagues but never come across to the standard specifying the number of spare cylinders against BA sets.

Substantiation: The proposal will assist when new introduced fire station (zero base fire station i.e. if the fire station decided to have 10 BA sets (including appliances and back up sets in general) then the required of additional 10 spare BA cylinders might be essential. Thus will cover for BA wearer to use 2 cylinders plus contingencies such as lost of air incase face mask visor broken any other technical faults that cause lost of air, vast emergencies, volunteers, outage of cylinders for hydrostatic pressure test etc.

Committee Meeting Action: Reject

Committee Statement: NFPA 1981 is a performance standard, not a use or selection, care and maintenance standard. The proposal deals with an issue related to SCBA selection.

1981-10 Log #CP2 FAE-RPE
(Chapters 2, 3, 6, 7, 8)

Final Action: Accept

Submitter: Technical Committee on Respiratory Protection Equipment,

Recommendation: Add the following new references to Chapter 2:

2.3.X IEC Publications. International Electrotechnical Commission, 3, rue de Varembe P.O. Box 131, 1211 Geneva 20, Switzerland

2.3.X.1 IEC 60268-16:2003, Sound System Equipment – Part 16: Objective Rating of Speech Intelligibility by Speech Transmission Index.

Add the following definitions to Chapter 3:

3.3.X (HATS) Head and Torso Simulator. A Head and Torso Simulator is a mannequin with built-in ear and mouth simulators that provides a realistic reproduction of the acoustic properties of an average adult human head and torso.

3.3.X.1 (STI) Speech Transmission Index. A measure of intelligibility of speech quality on a scale of intelligibility whose values varies from 0 = completely unintelligible to 1 = perfect intelligibility.

3.3.X.2 (SPL) Sound Pressure Level. The local pressure deviation from the ambient (average or equilibrium) atmospheric pressure caused by a sound wave.

6.1.10 All SCBA shall have a voice communications system that, at a minimum, shall consist of a mechanical speaking diaphragm.

6.1.10.1 The voice communications system shall be designed to project sound without other persons needing a receiver to hear the voice communications.

6.1.10.2 Where the voice communications system uses electronics, the design shall incorporate an indicator that the system is “on.” This indicator shall be permitted to be positioned outside the user’s field of vision with the SCBA facepiece properly donned.

6.1.10.3 Where the voice communications system uses electronics, the power source shall display a visual alert signal indicating low power capacity.

6.1.10.4 Where the voice communications system uses electronics, the voice communications system shall be designed to be switched off and on manually without the performance of the SCBA being affected.

6.1.10.5 Where the voice communications system is automatically activated, the operation of the on/off control shall override the auto activation of the voice communications system without affecting the performance of the SCBA.

6.1.10.6 Where the voice communications system uses electronics, the voice communications system shall be permitted to be equipped with an adjustable volume (gain) control.

Revise text to read as follows:

7.10 Non-Electronic Mechanical Diaphragm Communications Performance Requirements. The SCBA non-electronic voice communications system shall be tested for communications performance as specified in Section 8.10, Mechanical Voice Diaphragm Non-Electronic Communications Test, and shall have a Speech Transmission Index (STI) value of not less than ~~80~~ 0.45 percent.

7.17 Supplementary Voice Communications System Performance Requirements. If the SCBA is equipped with a supplementary voice communications system as identified by the SCBA manufacturer, it shall be tested for communications performance as specified in Section 8.10 ~~25~~, Mechanical Voice Diaphragm Voice Communications System Test, and shall have a Speech Transmission Index (STI) value of not less than ~~80~~ 0.50 percent.

8.10 Mechanical Voice Diaphragm Non-electronic Communications Test.

8.10.1 Application. This test method shall apply to complete SCBA facepiece(s) and second stage regulator(s).

8.10.2 Samples. Each sample to be tested shall be as specified in 4.3.9 with all voice communications systems installed, including supplementary voice communications systems, and in the “off” mode per manufacturer instructions.

8.10.3.2 Specimens for conditioning shall be complete medium size SCBA facepiece(s) and inner mask(s) with the second stage regulator(s) installed in the as worn position as specified by the manufacturer and with the regulator set in breathing mode and sealed from the ambient environment.

8.10.4.1 Testing shall be conducted in a chamber that absorbs a minimum of 90 percent of all sound from 500 Hz to 5000 Hz having the following characteristics:

(1) Room dimensions (minimum) with acoustic treatments: 3.6 m long X 3.0 m wide X 2.4 m high (12 ft long X 10 ft wide X 8 ft high) with a minimum volume of 27.2 m³ (960 ft³).

(2) Construction: Hemi-anechoic

(3) Ambient noise level inside chamber: <40 dBA/<50 dBC

(4) Walls and ceiling: ≥90% absorptive between 125 Hz and 8 kHz

8.10.4.1.1 All surfaces above the floor shall be acoustically treated for internal acoustic absorption, as well as for

external noise mitigation.

~~8.10.4.2 Five listening subjects and five talkers consisting of four males and one female shall be available for testing. The alternative of electronic recording of five talkers for testing automation and repeatability shall be permitted.~~

~~8.10.4.2 The Head and Torso Simulator (HATS) test mannequin having the following characteristics shall be used:~~

~~8.10.4.2.1 The mouth simulator shall be capable of producing 112 dB/1 kHz sine tone at 25 mm (1 inch) with the mouth reference point un-equalized and the total harmonic distortion (THD) shall be $\leq 3\%$.~~

~~8.10.4.2.2 The mouth simulator frequency response shall be able to be equalized flat ± 2 dB between 180 Hz and 10 kHz and the response shall be -15 dB or less at 100 Hz and -20 dB or less at 15 kHz.~~

~~8.10.4.2.3 The head of the HATS shall be anatomically correct to ensure the proper fit of the facepiece.~~

~~8.10.4.3 The subjects participating as listeners shall have "audiometrically normal" hearing as defined in Section 5.3 of ANSI S3.2, Method for Measuring the Intelligibility of Speech over Communication Systems, in the range of 500 Hz to 3000 Hz and shall not be permitted to use any device that would enhance their ability to hear.~~

~~8.10.4.3 A sound pressure level (SPL) meter having the following characteristics shall be used:~~

~~(1) The SPL meter shall be capable of applying an equivalent continuous sound pressure level (Leq) with A and C weighting filters.~~

~~(2) The SPL meter shall have a dynamic range from 30 dB (or less) to 130 dB (or more).~~

~~(3) The SPL meter shall display the measurement to at least one decimal place.~~

~~8.10.4.4 Talkers and listeners shall be selected and trained according to Section 7 of ANSI S3.2, Method for Measuring the Intelligibility of Speech over Communication Systems.~~

~~8.10.4.4 Test signal/pink noise analog audio signal generators having the following characteristics shall be used:~~

~~8.10.4.4.1 One generator shall be capable of playing wave files in the following format:~~

~~(1) 48 kHz, 16-bit mono at an output level of 0 dB, FS=18 dBu sine according to EBU R68~~

~~8.10.4.4.2 The second generator shall be capable of generating pink noise and sine waves from -80 dBu to -2 dBu in one digit steps with a THD+N of -90 dB (0.0032%) at 8 dBu noise floor typ 25uv.~~

~~(1) The frequency range shall be 10 Hz to 20 kHz in 1 digit steps $\pm 0.01\%$.~~

~~(2) The amplitude accuracy shall be within ± 0.5 dB or less.~~

~~8.10.4.5 The five talkers shall not have facial hair, any unusual facial characteristics, or any other condition that could cause interference with the seal of the facepiece.~~

~~8.10.4.5 A digital equalizer having the following characteristics shall be used:~~

~~(1) The digital equalizer shall be capable of at least two concurrently selectable equalizer sections:~~

~~(a) One-31 band graphic with an adjustment range of at least ± 18 dB.~~

~~(b) A ten band parametric with an adjustment range of at least ± 18 dB.~~

~~(2) The digital equalizer shall have a dynamic range of ≥ 112 dB.~~

~~(3) The digital equalizer shall be capable of:~~

~~(a) equalizing the frequency response of the HATS mannequin to flat ± 2 dB between 180 Hz and 10 kHz.~~

~~(b) applying a 180 Hz high pass filter with a slope of -24 dB octave.~~

~~(c) applying a 10 Hz low pass filter with a slope of -24 dB octave (-15 dB at 100 Hz – 20 dB at 15 kHz).~~

~~8.10.4.6 The talkers shall perform and pass a qualitative facepiece-to-face fit check per the SCBA manufacturer's instructions.~~

~~8.10.4.6 A powered speaker having the following characteristics shall be used:~~

~~(1) A sensitivity of ≥ 84 dB at one watt at 1 meter.~~

~~(2) The frequency response shall be rated at ≤ 80 Hz to ≥ 13 kHz.~~

~~(3) The amplifier shall be able to deliver ≥ 10 watts with a total harmonic distortion $< 1\%$.~~

~~8.10.4.7 Where the talker is qualified to wear several sizes of facepieces, the talker shall choose the facepiece that is most comfortable.~~

~~8.10.4.7 A microphone having the following characteristics shall be used:~~

~~(1) The microphone shall be a condenser type.~~

~~(2) The microphone polar pattern shall be omni-directional.~~

~~(3) The frequency response shall be flat ± 0.5 dB from 100 Hz to 15 kHz.~~

~~(4) The residual noise shall be ≤ 30 dB.~~

~~(5) The microphone shall accept signals of at least 130 dBA.~~

~~8.10.4.8 The five talkers shall be trained in the donning and usage of the SCBA per manufacturer's instructions.~~

~~8.10.4.8 A Speech Transmission Index (STI) analyzer having the following characteristics shall be used:~~

~~(1) The STI PA analyzer shall be capable of measuring and displaying a single value STI PA result to two decimal places with a 7 octave band modulated noise test signal using the Netherlands Organization for Applied Scientific Research (TNO) verified algorithm.~~

~~(2) The STI PA analyzer shall conform to IEC-60268-16:2003, Sound System Equipment – Part 16: Objective Rating of~~

Speech Intelligibility by Speech Transmission Index.

8.10.4.9 All of the apparatus identified in 8.10.4.2, 8.10.4.3, 8.10.4.4, 8.10.4.5, 8.10.4.6, and 8.10.4.7 shall be located in the hemi-anechoic chamber (Figures 8.10.4.9a and 8.10.4.9b).

~~***Insert Figure 8.10.4.9(a) Hemi-Anechoic Chamber***~~

~~***Insert Figure 8.10.4.9(b) Hemi-Anechoic Chamber***~~

~~8.10.4.9 The five talkers shall have no obvious speech defect or strong regional accent.~~

8.10.4.10 The HATS test mannequin shall be positioned in the chamber in the following manner:

8.10.4.10.1 The distance between the HATS test mannequin and the microphone shall be 1.5 m, +25 mm/-0 mm (5 ft, +1 in/-0 ft), and they shall be facing each other.

8.10.4.10.2 The distance between the HATS test mannequin's mouth and the floor shall be 1.5 m, +25 mm/-0 mm (5 ft, ± 4 in).

8.10.4.10.3 The distance between the microphone and the floor shall be 1.5 m, ± 100 mm (5 ft ± 4 in).

8.10.4.10 The distance between the talker and the listener(s) shall be 1.5 m, +305 mm/-0 mm (5 ft, +1 ft/-0 ft), and they shall be facing each other.

~~8.10.4.11 The test chamber shall be filled with broadband "pink" noise with a tolerance of 6 dB per octave band from 400 100 Hz to 4000 10 kHz.~~

~~8.10.4.12 The forward axis of the powered speaker ~~loudspeaker~~ shall be oriented away from the ~~listener group~~ HATS test mannequin microphone.~~

~~8.10.4.13 The distance between the powered speaker ~~loudspeaker~~ and the HATS test mannequin microphone ~~listeners~~ shall be as great as possible so as to create a quasi-uniform sound field over the ~~listening group~~ hemi-anechoic chamber microphone.~~

8.10.4.15 The STI test signal from the mannequin shall be adjusted to achieve a C-weighted sound level of 105.5 dB, +0 dB/-1 dB at the mouth reference point (MRP), 50 mm (2 in) from the test mannequin's mouth ±3 mm (1/8 in).

8.10.4.16 The gain of the powered speaker used to generate the pink noise shall be adjusted to achieve a C-weighted sound level of 15 dB ±0.5 dB below the signal level generated as identified in 8.10.4.15 measured at the microphone placed as identified in 8.10.4.10.1.

~~8.10.5.1 The method for measuring speech transmission index ~~word intelligibility~~ shall be as specified in ANSI S3.2, Method for Measuring the Intelligibility of Speech over Communication Systems IEC 60268-16:2003, Sound System Equipment – Part 16: Objective Rating of Speech Intelligibility by Speech Transmission Index, using the STI-PA technique, with the modified apparatus specified in 8.10.4.~~

8.10.5.2 The medium size facepiece with inner mask and second stage regulator in the normal use mode shall be fitted to the HATS test mannequin in the following manner:

(1) Place the chin of the mannequin in the "chin cup" of the facepiece.

(2) Place the facepiece to seal against the face of the HATS test mannequin.

(3) The head harness of the facepiece shall be passed over the HATS test mannequin and tightened in a manner that maintains the symmetry of the facepiece on the HATS test mannequin with talc to minimize friction between the HATS test mannequin and strap.

(4) The straps shall be tightened to a tension of 50 N (11.2 lbf).

~~8.10.5.2 The test material shall be the reading of one complete list of modified rhyme words as contained in Table 2 of ANSI S3.2, Method for Measuring the Intelligibility of Speech over Communication Systems:~~

~~8.10.5.2.1 The words shall be spoken singularly in the following carrier sentence: "Would you circle [list word] now?"~~

~~8.10.5.2.2 The rate shall be approximately one test word every 6 seconds.~~

~~8.10.5.2.3 The talkers shall be trained to talk at 75 dBA to 85 dBA without an SCBA facepiece, measured at the listener's ear, placing no unusual stress on any word.~~

~~8.10.5.2.4 Training shall include the use of background noise as defined in 8.10.4.11 through 8.10.4.15.~~

~~8.10.5.2.5 The talkers shall not vary their voice level from that used without the facepiece after the facepiece is donned.~~

~~8.10.5.2.6 The listeners shall circle each word as they hear it.~~

8.10.5.3 ~~Three medium size facepieces~~ The talkers shall be tested ~~conduct two tests~~ in the chamber having an ambient noise field as specified in 8.10.4.11 through 8.10.4.15, ~~using a different word list for each of the following conditions:~~ Each facepiece shall be mounted as specified in 8.10.5.2, and then tested as follows:

~~(1) ~~With no SCBA~~ Five separate readings shall be recorded for each donning of the facepiece.~~

~~(2) ~~With SCBA worn and operated per the SCBA manufacturer's instructions~~ Three separate donnings shall be~~

NFPA 1981

Log CP 2

Figure 8.10.4.9 (a) Hemi-Anechoic Chamber 1

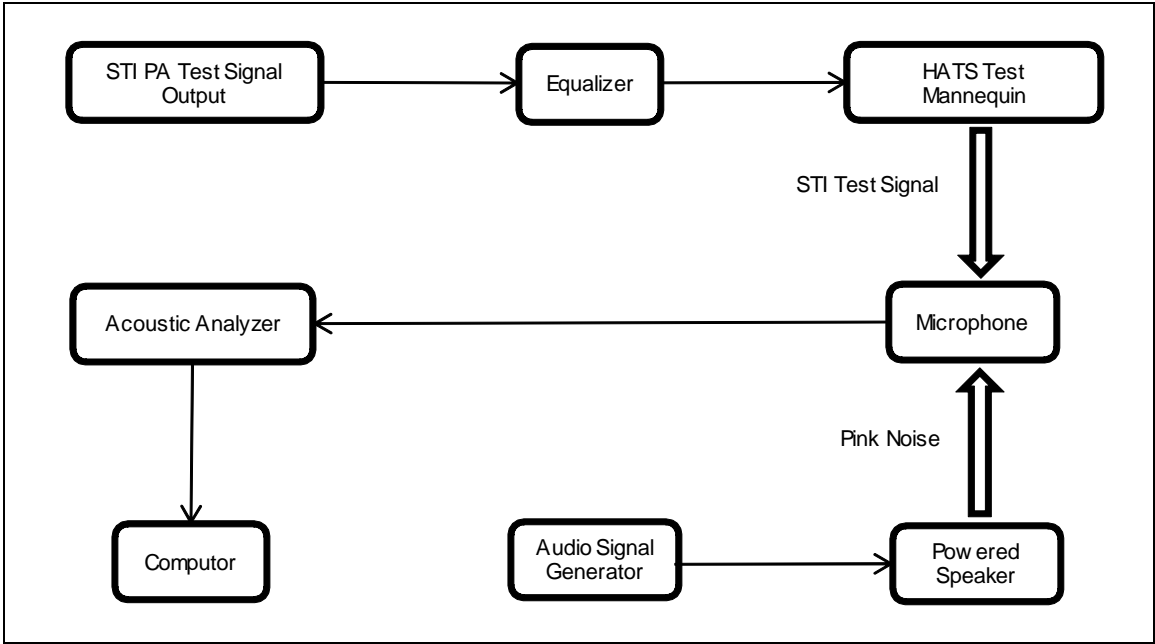

NFPA 1981

Log CP 2

Figure 8.10.4.9 (b) Hemi-Anechoic Chamber 2

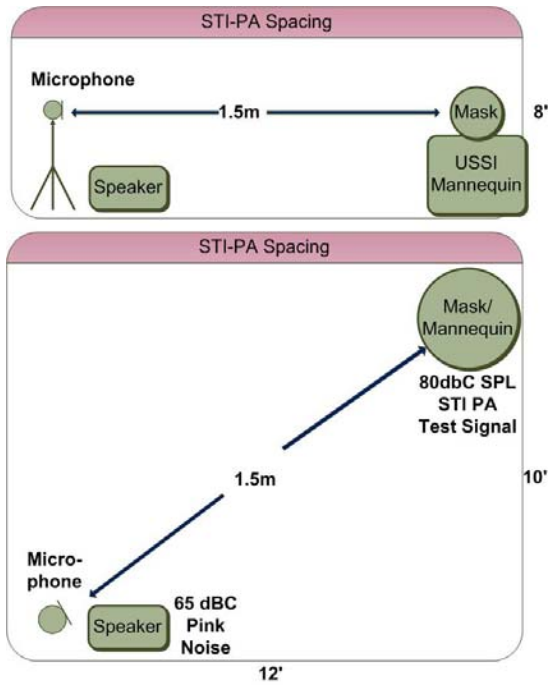

performed

~~8.10.5.4 Talkers' speech shall be monitored during the tests to determine if the talkers conform to the word list specified for that test.~~

~~8.10.5.5 Each listener's response form shall be scored as to the number of correct responses out of the 50 words recited:~~

~~8.10.5.5.1 Listeners' scores shall be based on the words actually spoken by the talkers.~~

~~8.10.5.5.2 Listeners' scores shall not be reduced because of speaking mistakes of the talkers.~~

~~8.10.5.5.3 All of the listeners' scores without the SCBA used by the talker shall be averaged, and all of the listeners' scores with the SCBA used by the talker shall be averaged.~~

~~8.10.5.5.4 The average score of the five listeners for the talker using the SCBA shall be divided by the average score of the five listeners for the talker without using the SCBA, and the result shall be called the "score value." This procedure shall be performed for each of the five talkers.~~

~~8.10.5.6 The average of the score values obtained in 8.10.5.5.3 and 8.10.5.5.4 shall be calculated.~~

~~8.10.5.6.1 Where the average of the score values is ≥ 80 percent, this average score value shall be used to determine pass or fail.~~

~~8.10.5.5 All of the readings obtained from 8.10.5.3 shall then have the standard deviation calculated to determine the pass or fail performance.~~

~~8.10.5.5.1 The sample standard deviation (s.d.) of the score values shall be calculated in the following manner:~~

~~***Insert Equation 8.10.5.5.1 Here***~~

where:

\bar{x} = score values

x = average of the score values

N = sample size (number of score values recorded)

~~8.10.5.6.3 Where the calculated sample standard deviation of the test score values is ≥ 10.0 , the test shall be invalidated and the procedures of 8.10.5.2 through 8.10.5.6.6 shall be repeated.~~

~~8.10.5.6.4 Where the calculated sample standard deviation of the test score values is < 10.0 , a test statistic, T-value, shall be calculated to determine if the average of the score values obtained is or is not equivalent to 80 percent. The T-value shall be calculated in the following manner:~~

~~8.10.5.6.5 For T-values ≤ 2.13 , the score value shall be considered 80 percent and shall be used to determine pass or fail.~~

~~8.10.5.6. For T-values > 2.13 , the score value shall be as calculated in 8.10.5.6, and this calculated score value shall be used to determine pass or fail performance.~~

~~8.25.1 Application. This test method shall apply to complete SCBA facepiece(s) and second stage regulator(s).~~

~~8.25.2 Samples. Each sample to be tested shall be as specified in 4.3.9.~~

~~8.25.3.2 Specimens for conditioning shall be complete SCBA medium size SCBA facepiece(s) and inner mask(s) with the second stage regulator(s) installed in the as worn position as specified by the manufacturer.~~

~~8.25.4.1 Testing shall be conducted in a chamber that absorbs a minimum of 90 percent of all sound from 500 Hz to 5000 Hz: having the following characteristics shall:~~

~~(1) Room dimensions (Minimum): 3.6 m long X 3.0 m wide X 2.4 m high (12 ft long X 10 ft wide X 8 ft high) with a minimum volume of 27.2 m³ (960 ft³).~~

~~(2) Construction: Hemi-anechoic~~

~~(3) Ambient noise level inside chamber: < 40 dBA/ < 55 dBC~~

~~(4) Walls and ceiling: $\geq 90\%$ absorbtive above 100 Hz~~

~~8.25.4.1.1 All surfaces above the floor shall be acoustically treated for internal acoustic absorption, as well as for external noise mitigation.~~

~~8.25.4.2 Five listening subjects and five talkers consisting of four males and one female shall be available for testing. The alternative of electronic recording of five talkers for testing automation and repeatability shall be permitted.~~

~~8.25.4.2 The Head and Torso Simulator (HATS) test mannequin having the following characteristics shall be used:~~

~~8.25.4.2.1 The mouth simulator shall be capable of producing 112 dB/1 kHz sine tone at 25 mm (1 inch) with the mouth reference point un-equalized and the total harmonic distortion (THD) shall be $\leq 3\%$.~~

~~8.25.4.2.2 The mouth simulator frequency response shall be able to be equalized flat ± 2 dB between 180 Hz and 10 kHz and the response shall be -15 dB or less at 100 Hz and -20 dB or less at 15 kHz.~~

~~8.25.4.2.3 The head of the HATS shall be anatomically correct to ensure the proper fit of the facepiece.~~

NFPA 1981

Log CP 2

Figure 8.10.5.5.1

$$s.d. = \sqrt{\frac{\sum_{i=1}^N (x_i - \bar{x})^2}{N - 1}}$$

~~8.25.4.3 The subjects participating as listeners shall have “audiometrically normal” hearing as defined in Section 5.3 of ANSI S3.2, Method for Measuring the Intelligibility of Speech over Communication Systems, in the range of 500 Hz to 3000 Hz, and shall not be permitted to use any device that would enhance their ability to hear.~~

~~8.25.4.3 A sound pressure level (SPL) meter having the following characteristics shall be used:~~

~~(1) The SPL meter shall be capable of applying an equivalent continuous sound pressure level (Leq) of A and C weighting filters.~~

~~(2) The SPL meter shall have a dynamic range from 30 dB (or less) to 130 dB (or more).~~

~~(3) The SPL meter shall display the measurement to at least one decimal place.~~

~~8.25.4.4 Talkers and listeners shall be selected and trained according to Section 7 of ANSI S3.2, Method for Measuring the Intelligibility of Speech over Communication Systems.~~

~~8.25.4.4 Test signal/pink noise analog audio signal generators having the following characteristics shall be used:~~

~~8.25.4.4.1 One generator shall be capable of playing wave files in the following format:~~

~~(1) 48 kHz, 16-bit mono at an output level of 0 dB, FS=18 dBu sine according to EBU R68~~

~~8.25.4.4.2 The second generator shall be capable of generating pink noise and sine waves from -80 dBu to -2 dBu in one digit steps with a THD+N of -90 dB (0.0032%) at 8 dBu noise floor typ 25uv.~~

~~(1) The frequency range shall be 10 Hz to 20 kHz in 1 digit steps $\pm 0.01\%$.~~

~~(2) The amplitude accuracy shall be within ± 0.5 dB or less.~~

~~8.25.4.5 The five talkers shall not have facial hair, any unusual facial characteristics, or any other condition that could cause interference with the seal of the facepiece.~~

~~8.25.4.5 A digital equalizer having the following characteristics shall be used:~~

~~(1) The digital equalizer shall be capable of at least two concurrently selectable equalizer sections:~~

~~(a) One-31 band graphic with an adjustment range of at least ± 18 dB.~~

~~(b) A ten band parametric with an adjustment range of at least ± 18 dB.~~

~~(2) The digital equalizer shall have a dynamic range of ≥ 112 dB.~~

~~(3) The digital equalizer shall be capable of:~~

~~(a) equalizing the frequency response of the HATS mannequin to flat ± 2 dB between 180 Hz and 10 kHz.~~

~~(b) applying a 180 Hz high pass filter with a slope of -24 dB octave.~~

~~(c) applying a 10 Hz low pass filter with a slope of -24 dB octave (-15 dB at 100 Hz – 20 dB at 15 kHz).~~

~~8.25.4.6 The talkers shall perform and pass a qualitative facepiece-to-face fit check per the SCBA manufacturer's instructions.~~

~~8.25.4.6 A powered speaker having the following characteristics shall be used:~~

~~(1) A sensitivity of ≥ 84 dB at one watt at 1 meter.~~

~~(2) The frequency response shall be rated at ≤ 80 Hz to ≥ 13 kHz.~~

~~(3) The amplifier shall deliver ≥ 10 watts with a total harmonic distortion $< 1\%$.~~

~~8.25.4.7 Where the talker is qualified to wear several sizes of facepieces, the talker shall choose the facepiece that is most comfortable.~~

~~8.25.4.7 A microphone having the following characteristics shall be used:~~

~~(1) The microphone shall be a condenser type.~~

~~(2) The microphone polar pattern shall be omni-directional.~~

~~(3) The frequency response shall be flat ± 0.5 dB from 100 Hz to 15 kHz.~~

~~(4) The residual noise shall be ≤ 30 dB.~~

~~(5) The microphone shall accept signals of at least 130 dBA.~~

~~8.25.4.8 The five talkers shall be trained in the donning and usage of the SCBA per manufacturer's instructions.~~

~~8.25.4.8 A Speech Transmission Index (STI) analyzer having the following characteristics shall be used:~~

~~(1) The STI PA analyzer shall be capable of measuring and displaying a single value STI PA result to two decimal places with a 7 octave band modulated noise test signal using the Netherlands Organization for Applied Scientific Research (TNO) verified algorithm.~~

~~(2) The STI PA analyzer shall conform to IEC-60268-16:2003, Sound System Equipment – Part 16: Objective Rating of Speech Intelligibility by Speech Transmission Index.~~

~~8.25.4.9 All of the apparatus identified in 8.25.10.4.2, 8.25.4.3, 8.25.4.4, 8.25.4.5, 8.25.4.6, 8.25.4.7 shall be located in the hemi-anechoic chamber (Reference Figure 8.25.4.9a and 8.25.4.9b).~~

*** Insert Figure 8.25.4.9(a) Here***

*** Insert Figure 8.25.4.9(b) Here***

NFPA 1981

Log CP 2

Figure 8.25.4.9 (a) Hemi-Anechoic Chamber 1

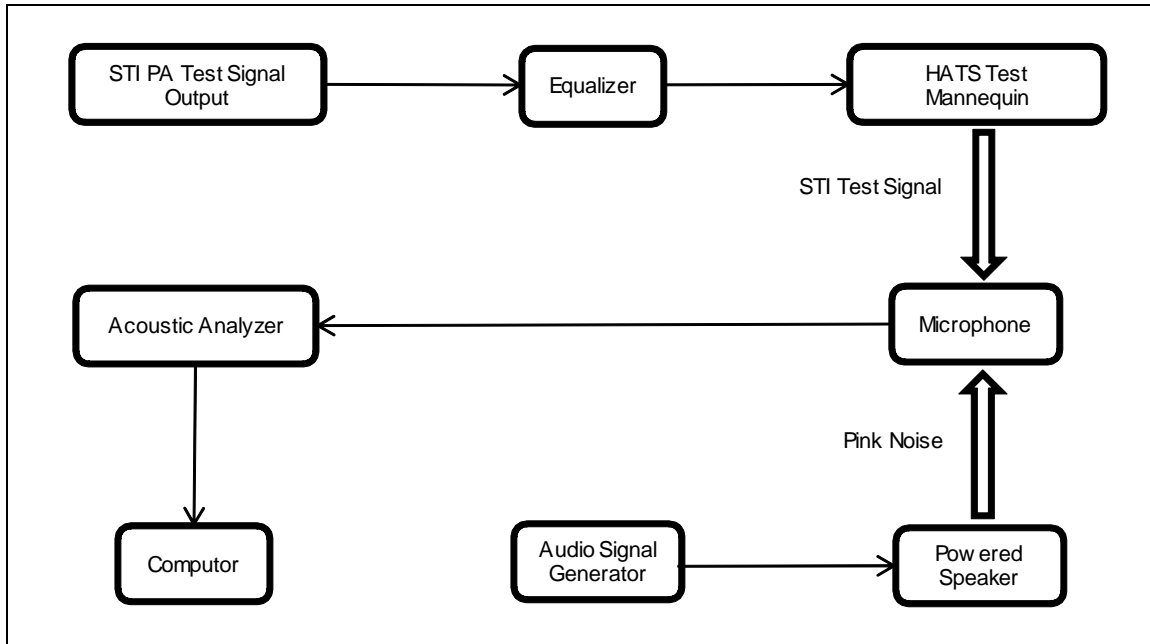

NFPA 1981

Log CP 2

Figure 8.25.4.9 (b) Hemi-Anechoic Chamber 2

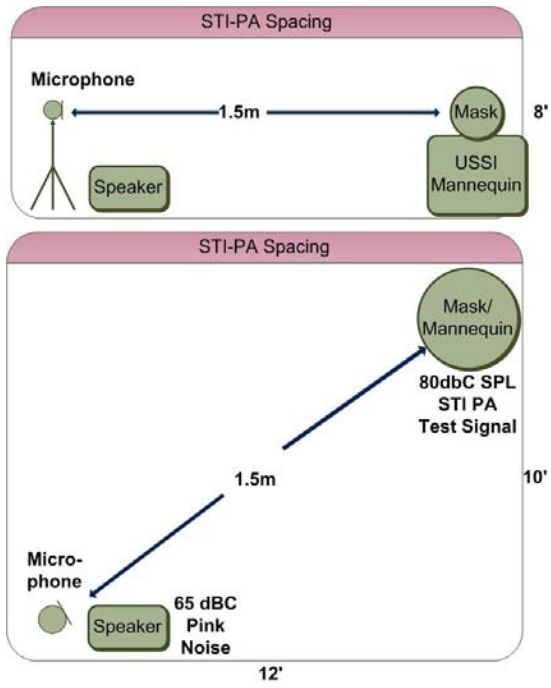

~~8.25.4.9 The five talkers shall have no obvious speech defects or strong regional accents.~~

~~8.25.4.10 The HATS test mannequin shall be positioned in the chamber in the following manner:~~

~~8.25.4.10.1 The distance between the HATS test mannequin and the microphone shall be 1.5 m, +25 mm/-0 mm (5 ft, +1 in/-0 ft), and they shall be facing each other.~~

~~8.25.4.10.2 The distance between the HATS test mannequin's mouth and the floor shall be 1.5 m, +25 mm/-0 mm (5 ft, ± 4 in).~~

~~8.25.4.10.3 The distance between the microphone and the floor shall be 1.5 m, ± 100 mm/(5 ft ± 4 in).~~

~~8.25.4.10 The distance between the talker and the listener(s) with the SCBA donned shall be 3 m, +305 mm/-0 mm (10 ft, +1 ft/-0 ft), and they shall be facing each other.~~

~~8.25.4.10.1 The distance between the talker and the listener(s) without the SCBA donned shall be 3 m, +305 mm/-0 mm (10 ft, +1 ft/-0 ft), and they shall be facing each other.~~

~~8.25.4.11 The test chamber shall be filled with broadband "pink" noise with a tolerance of 6 dB per octave band from 400 100 Hz to 4000 10 kHz.~~

~~8.25.4.12 The forward axis of the powered speaker loudspeaker shall be oriented away from the listener group HATS test mannequin microphone.~~

~~8.25.4.13 The distance between the powered speaker loudspeaker and the HATS test mannequin microphone listeners shall be as great as possible so as to create a quasi-uniform sound field over the listening group hemi-anechoic chamber microphone.~~

~~8.25.4.15 The STI test signal from the mannequin shall be adjusted to achieve a C-weighted sound level of 105.5 dB, +0 dB/-1 dB at the mouth reference point (MRP), 50 mm (2 in.) from the test mannequin's mouth ±3 mm (1/8 in).~~

~~8.25.4.16 The gain of the powered speaker amplifier used to generate the pink noise shall be adjusted to achieve a C-weighted sound level of 15 dB ±0.5 dB below the signal level generated as identified in 8.25.4.15 measured at the microphone placed as identified in 8.25.4.10.1, at each listener's the test mannequin's head position, without listeners present.~~

~~8.25.5.1 The method for measuring speech transmission index word intelligibility shall be as specified in ANSI S3.2, Method for Measuring the Intelligibility of Speech over Communication Systems IEC 60268-16:2003, Sound System Equipment – Part 16: Objective Rating of Speech Intelligibility by Speech Transmission Index, using the STI-PA technique, with the modified apparatus specified in 8.25.4.~~

~~8.25.5.2 The medium size facepiece with inner mask and second stage regulator in the normal use mode shall be fitted to the HATS test mannequin in the following manner:~~

~~(1) Place the chin of the mannequin in the "chin cup" of the facepiece.~~

~~(2) Place the facepiece to seal against the face of the HATS test mannequin.~~

~~(3) The head harness of the facepiece shall be passed over the HATS test mannequin and tightened in a manner that maintains the symmetry of the facepiece on the HATS test mannequin with talc to minimize friction between the HATS test mannequin and strap.~~

~~(4) The straps shall be tightened to a tension of 50 N (11.2 lbf).~~

~~8.25.5.2.1 Where the voice communications system is equipped with an adjustable volume (gain) control, the volume control shall be set at the lowest level during testing.~~

~~8.25.5.3 If the voice amplification system is integrated into the SCBA, the SCBA shall be mounted on the test mannequin to simulate the correct wearing position on a person as specified by the SCBA manufacturer's instructions. The speaker of the voice amplification system shall face in the direction of the microphone to within +/- 10 degrees.~~

~~8.25.5.3.1 Where the voice communications system is equipped with an adjustable volume (gain) control, the volume control shall be set at the lowest level during testing.~~

~~8.25.5.3 The test material shall be the reading of one complete list of modified rhyme words as contained in Table 2 of ANSI S3.2, Method for Measuring the Intelligibility of Speech over Communication Systems.~~

~~8.25.5.3.1 The words shall be spoken singularly in the following carrier sentence: "Would you circle [list word] now?"~~

~~8.25.5.3.2 The rate shall be approximately one test word every 6 seconds.~~

~~8.25.5.3.3 The talkers shall be trained to talk at 75 dBA to 85 dBA without an SCBA facepiece, measured at 1.5 m, +305 mm/-0 mm (5 ft, +1 ft/-0 ft) distance at the height of the listener's ear, placing no unusual stress on any word.~~

~~8.25.5.3.4 Training shall include the use of background noise as defined in 8.25.4.11 through 8.25.4.15.~~

~~8.25.5.3.5 The talkers shall not vary their voice levels from that used without the facepiece after the facepiece is donned.~~

~~8.25.5.3.6 The listeners shall circle each word as they hear it.~~

~~8.25.5.4 Three medium size facepieces. The talkers shall be tested conduct two tests in the chamber having an ambient noise field as specified in 8.25.4.11 through 8.25.4.15, using a different word list for each of the following conditions. Each facepiece shall be mounted as specified in 8.25.5.2, and then tested as follows:~~

~~(1) With no SCBA. Five separate readings shall be recorded for each donning of the facepiece~~

(2) With SCBA worn and operated per the SCBA manufacturer's instructions Three separate donnings shall be performed.

8.25.5.5 The talkers' speech shall be monitored during the tests to determine if the talkers conform to the word list specified for that test.

8.25.5.6 Each listener's response form shall be scored as to the number of correct responses out of the 50 words recited:

8.25.5.6.1 Listeners' scores shall be based on the words actually spoken by the talkers.

8.25.5.6.2 Listeners' scores shall not be reduced because of speaking mistakes of the talkers.

8.25.5.6.3 All of the listeners' scores without the SCBA used by the talker shall be averaged, and all of the listeners' scores with the SCBA used by the talker shall be averaged.

8.25.5.6.4 The average score of the five listeners for the talker using the SCBA at a distance of 3 m, +305 mm/-0 mm (10 ft, +1 ft/-0 ft) shall be divided by the average score of the five listeners for the talker without using the SCBA at a distance of 1.5 m, +305 mm/-0 mm (5 ft, +1 ft/-0 ft), and the result shall be called the "score value." This procedure shall be performed for each of the five talkers.

8.25.5.7 The average of the score values obtained in 8.25.5.6.3 and 8.25.5.6.4 shall be calculated.

8.25.5.5 All of the readings obtained from 8.25.5.4 shall then have the standard deviation calculated to determine the pass or fail performance:

8.25.5.7.1 Where the average of the score values is ≥ 85 percent, this average score value shall be used to determine pass or fail performance:

8.25.5.5.1 Where the average of the score values is < 85 percent; The sample standard deviation (s.d.) of the score values shall be calculated in the following manner:

Insert Equation 8.25.5.5.1 Here

where:

\bar{x} = score values

\bar{x} = average of the score values

N = sample size (number of score values recorded)

8.25.5.7.3 Where the calculated sample standard deviation of the test score values is ≥ 10.0 , the test shall be invalidated, and the procedures in 8.25.5.3 through 8.25.5.7.2 shall be repeated.

8.25.5.7.4 Where the calculated sample standard deviation of the test score values is < 10.0 , a test statistic, T-value, shall be calculated to determine if the average of the score values obtained is or is not equivalent to 85 percent:

8.25.5.7.5 For T-values ≤ 2.13 , the score value shall be considered to be equivalent to a score value of 85 percent.

8.25.5.7.6 For T-values ≥ 2.13 , the score value shall be as calculated in 8.25.5.6, and this calculated score value shall be used to determine pass or fail.

Annex A Explanatory Material

A.7.10 Because the communications test requires human subjects, there were variations in the data used to determine the appropriate pass or fail criteria. Therefore, a statistical approach to analyze the data was required to determine whether an individual SCBA meets the pass or fail criteria of Section 7.10. A null hypothesis test utilizing the Student t-distribution is the appropriate method to do this. The Student t-distribution of 2.13 results from the following conditions: degrees of freedom = 4; confidence level = 95 percent. Refer to any current statistical text for further information:

A.7.10 In an effort to improve the consistency and reliability of speech intelligibility measurements, the National Fire Protection Association (NFPA) 1981 Technical Committee reviewed several objective test methods in order to replace the subjective Modified Rhyme Test (MRT). The subjectivity of the MRT is associated with the use of human test subjects which resulted in variability in the results obtained. The variances were in the uses of different speakers, the speaker's vocalization level, the speaker's accent/dialect differing from the listeners, the general health and wellness of both the speaker and listeners, and the impact of background noise on the listener's comprehension.

In order to find an objective test method the Technical Committee reviewed/conducted:

Acoustic standards, research papers, existing scientific studies, and professional acoustic engineers were consulted

A trade study for evaluating alternative tests was defined

Trade Study criteria

Relevance - evaluate relevance to fire service

NFPA 1981

Log CP 2

Figure 8.25.5.5.1

$$s.d. = \sqrt{\frac{\sum_{i=1}^N (x_i - \bar{x})^2}{N - 1}}$$

Consistency - evaluate consistency of testing - repeatability/test-to-test variability

Comprehensiveness - ability to account for real-life sound degradations

Output scale – tests with a higher percentage of the test scale falling within the threshold of acceptability will provide more meaningful information

Standardization - utilize established test standards by respected organizations (ISO, IEC, ANSI, etc.)

Implementation Effort – how hard is the test to set-up and run

Measurement Time – how long does it take to run the test

As a result of this effort, the Technical Committee is utilizing the Speech Transmission Index (STI) method which removes the subjectivity which was found with the MRT.

A.7.17 In an effort to improve the consistency and reliability of speech intelligibility measurements, the National Fire Protection Association (NFPA) 1981 Technical Committee reviewed several objective test methods in order to replace the subjective Modified Rhyme Test (MRT). The subjectivity of the MRT is associated with the use of human test subjects which resulted in variability in the results obtained. The variances were in the uses of different speakers, the speaker's vocalization level, the speaker's accent/dialect differing from the listeners, the general health and wellness of both the speaker and listeners, and the impact of background noise on the listener's comprehension.

In order to find an objective test method the Technical Committee reviewed/conducted:

Acoustic standards, research papers, existing scientific studies, and professional acoustic engineers were consulted

A trade study for evaluating alternative tests was defined

Trade Study criteria

Relevance - evaluate relevance to fire service

Consistency - evaluate consistency of testing - repeatability/test-to-test variability

Comprehensiveness - ability to account for real-life sound degradations

Output scale – tests with a higher percentage of the test scale falling within the threshold of acceptability will provide more meaningful information

Standardization - utilize established test standards by respected organizations (ISO, IEC, ANSI, etc.)

Implementation Effort – how hard is the test to set-up and run

Measurement Time – how long does it take to run the test

As a result of this effort, the Technical Committee is utilizing the Speech Transmission Index (STI) method which removes the subjectivity which was found with the MRT.

Substantiation: The Technical Committee on Respiratory Protection's Task Group on Communications, in an effort to improve the consistency and reliability of speech intelligibility measurements, reviewed several objective test methods in order to replace the subjective Modified Rhyme Test (MRT). The subjectivity of the MRT is associated with the use of human test subjects which resulted in variability in the results obtained. The variances were in the uses of different speakers, the speaker's vocalization level, the speaker's accent/dialect differing from the listeners, the general health and wellness of both the speaker and listeners, and the impact of background noise on the listener's comprehension.

In order to find an objective test method the Technical Committee reviewed/conducted:

Acoustic standards, research papers, existing scientific studies, and professional acoustic engineers were consulted

A trade study for evaluating alternative tests was defined

Trade Study criteria

Relevance - evaluate relevance to fire service

Consistency - evaluate consistency of testing - repeatability/test-to-test variability

Comprehensiveness - ability to account for real-life sound degradations

Output scale – tests with a higher percentage of the test scale falling within the threshold of acceptability will provide more meaningful information

Standardization - utilize established test standards by respected organizations (ISO, IEC, ANSI, etc.)

Implementation Effort – how hard is the test to set-up and run

Measurement Time – how long does it take to run the test

As a result of this effort, the Technical Committee is utilizing the Speech Transmission Index (STI) method which

removes the subjectivity which was found with the MRT.

Committee Meeting Action: **Accept**

1981-11 Log #9 FAE-RPE **Final Action: Accept in Principle**
(2.3.6)

Submitter: Bob Eugene, Underwriters Laboratories Inc.

Recommendation: Revise text to read as follows:

2.3.6 UL Publications.

Underwriters Laboratories Inc., 333 Pfingsten Road, Northbrook, IL 60062-2096.

ANSI/UL 913, Standard for Intrinsically Safe Apparatus and Associated Apparatus for Use in Class I, II, and III, Division 1 Hazardous (Classified) Locations, ~~Sixth edition, July 31, 2006~~, Revised 2008.

Substantiation: Update referenced standard to most recent revision.

Committee Meeting Action: Accept in Principle

See meeting action on 1981-13 (Log #17).

Committee Statement: The technical committee accepted the proposal in principle. See 1981-13 (Log 17).

1981-12 Log #15 FAE-RPE **Final Action: Accept in Principle**
(2.3.6)

Submitter: John F. Bender, Underwriters Laboratories Inc.

Recommendation: Revise text to read as follows:

2.3.6 UL Publications. Underwriters Laboratories Inc., 333 Pfingsten Road, Northbrook, IL 60062-2096.

ANSI/UL 913, Standard for Intrinsically Safe Apparatus and Associated Apparatus for Use in Class I, II, and III, Division I Hazardous (Classified) Locations, 2006, Revised ~~2008~~ 2010.

Substantiation: Reason: Update referenced standards to most recent revisions.

Committee Meeting Action: Accept in Principle

See Meeting Action on 1981-13 (Log #17).

Committee Statement: See Committee Statement on 1981-13 (Log #17).

1981-13 Log #17 FAE-RPE **Final Action: Accept in Principle**
(2.3.6)

Submitter: John F. Bender, Underwriters Laboratories Inc.

Recommendation: Revise text as follows:

2.3.6 UL Publications. Underwriters Laboratories Inc., 333 Pfingsten Road, Northbrook, IL 60062-2096. ANSI/UL 913, *Standard for Intrinsically Safe Apparatus and Associated Apparatus for Use in Class I, II, and III, Division 1 Hazardous (Classified) Locations*, ~~Seventh edition, July 31, 2006~~, Revised 2010.

Substantiation: Reason: Update referenced standard to most recent revision.

Committee Meeting Action: Accept in Principle

Revise text to read as follows:

2.3.6 UL Publications. Underwriters Laboratories Inc., 333 Pfingsten Road, Northbrook, IL 60062-2096. ANSI/UL 913, *Standard for Intrinsically Safe Apparatus and Associated Apparatus for Use in Class I, II, and III, Division 1 Hazardous (Classified) Locations*, Seventh Edition.

Committee Statement: The technical committee accepted the proposal in principle, and decided to reference the seventh edition and not include the date.

1981-14 Log #CP3 FAE-RPE
(3.3 Reserve Air Supply, 6.2, 6.3)

Final Action: Accept

Submitter: Technical Committee on Respiratory Protection Equipment,

Recommendation: Revise text to read as follows:

3.3.X Reserve Air Supply. The period of time available for emergency egress, self-rescue, or assisted rescue.

3.3.17 End-of-Service-Time Indicator (EOSTI). A warning device on an SCBA that warns the user that the end of the breathing air supply is approaching: alerts the user that the reserve air supply is being utilized.

6.2.6 The EOSTI alarm shall activate at 33%, +5/-0%, of full cylinder pressure.

6.3.9.1 HUD shall display visual informational signals for at least breathing air cylinder content as specified in 6.3.9.5.1.

6.3.9.2 In addition to the mandatory visual informational signal specified in 6.3.9.5.1, additional visual informational signals to indicate when other status or conditions have occurred shall be permitted.

6.3.9.5 HUD shall display a visual informational signal for breathing air cylinder content in at least four equal increments of the cylinder's total rated service content from full to one-quarter 33%.

6.3.9.5.1 HUD visual information signals for breathing air cylinder content shall display at 100%, 75%, 50%, and 33%.

6.3.9.5.2 Where an analog visual display is used, the gauge shall visually indicate the reserve air zone with a red background.

6.3.9.5.3 Where an electronic visual display is used, the gauge shall visually indicate that reserve air is being utilized with a flash at a frequency of not less than one per second for the remaining duration of the cylinder.

Substantiation: Despite an overall decrease in the firefighter fatality rate over the past 30 years, the rate of firefighter deaths inside of structures has not significantly changed. Firefighter asphyxia following getting lost and running out of air accounts for approximately 25% of firefighter deaths inside of structures.

The current EOSTI setting of 25% (+/- 2%) may result in EOSTI notification at 23% of cylinder volume. A firefighter working near the end of a work cycle on SCBA is likely to be breathing at a rate greater than the 40 liter per minute rate used to determine rated service time and may have less than three minutes of reserve air. Increasing the EOSTI setting to 33% (+5/-0) will likely provide the user more reserve air for self or assisted escape from the IDLH environment.

For more information on this subject, see the NFPA research report "U.S. Fire Service Fatalities In Structure Fires, 1977-2009" (Fahy)

Committee Meeting Action: Accept

1981-15 Log #13 FAE-RPE
(4.2.8.2)

Final Action: Reject

Submitter: William Antunes, Structural Composites Industries

Recommendation: Revise text to read as follows:

Replacements parts, components, and add-on accessories for SCBA's certified to the 1997 edition or the 2002 edition of NFPA 1981 shall be approved by NIOSH in accordance with 42 CFR 84, "Respiratory Protective Devices, Tests for Permissibility." Cylinders that meet or exceed NIOSH's Technical Specifications under 42 CFR 84 are permissible for use by end users provided they are authorized by the Department of Transportation (DOT) approval process. Cylinders must be marked with the required DOT labeling. Manufacturer of these cylinders must maintain as ISO 9001 or AS9100 certification for quality assurance. Cylinders meeting this criteria that are of the same form, fit and function as those originally certified by NIOSH are permissible for use by end users and do not require certification by NIOSH.

Substantiation: 1) The current standard results in an economic hardship of end users by;

a) Unnecessarily increasing the cost of replacement cylinders without providing any additional value-added benefit
b) Requires purchase of new cylinders, prior to end of useful life, by end users when procuring different brands of SCBA

2) Current standard does not allow for cylinder innovation as the NIOSH approval is granted to Respirator Manufacturers who do not manufacture cylinders.

3) NIOSH's Standard Application Procedure (SAP) does not provide cylinder specific testing and approval certification. NIOSH's only technical requirement is DOT approval.

4) Cylinder durability is limited as end users are limited to few choices by NIOSH approval holders.

5) Interchangeability of cylinders is made difficult

a) Creates a proprietary system which restricts the ability of user to interchange cylinders

b) Closed and proprietary systems do nothing to mitigate safety concerns.

Committee Meeting Action: Reject

Committee Statement: Cylinders are certified by NIOSH as part of the entire SCBA system and are not certified as an independent component. NIOSH certification is required by law and utilizing an aftermarket cylinder would void NIOSH approval. NFPA 1981 requires NIOSH certification, so the technical committee must reject this proposal.

1981-16 Log #12 FAE-RPE
(6.1.2)

Final Action: Reject

Submitter: Jeffrey O. Stull, International Personnel Protection, Inc.

Recommendation: Revise text to read as follows:

6.1.2 Prior to certification of SCBA to the requirements of this standard, SCBA shall be NIOSH certified in accordance with 42 CFR 84, with the following modifications:

(1) Each remaining service-life indicator or warning device shall give an alarm when the remaining service life of the apparatus is reduced within a range as specified by the authority having jurisdiction but not less than 20 to 25 percent of its rated service time.

Substantiation: The requirement that SCBA be certified to the requirements of 42 CFR Part 84 is understood as OSHA regulations in 29 CFR Part 1910.132 dictated the NIOSH-approved respirators. However, in this case, the Federal regulations handicap the emergency service with requirements that were principally developed for industrial situations. The entire embodiment of NFPA 1981 is a testament to the additional requirements that must be specified for safe and effective use of SCBA for emergency services that are not included in the Federal regulations.

Committee Meeting Action: Reject

See Meeting Action on 1981-14 (Log #CP3).

Committee Statement: See Committee Statement on 1981-14 (Log #CP3).

1981-17 Log #14 FAE-RPE
(6.1.2.2)

Final Action: Reject

Submitter: Richard M. Duffy, International Association of Fire Fighters

Recommendation: Revise text to read as follows:

6.1.2.2 SCBA shall have a NIOSH-certified rated service time of at least ~~30~~ 45 minutes.

Substantiation: The fire service experiences a number of injuries and fatalities each year because fire fighters run out of air. The 30 minutes of air because the service life rating is based on 40 liters per minute service life. New cylinder technology is available and will be available that the weight differences for increased service life cylinders will be minimal.

Committee Meeting Action: Reject

See Meeting Action on 1981-14 (Log #CP3).

Committee Statement: See Committee Statement on 1981-14 (Log #CP3). The issue with duration is primarily one of escape time, not work time. The TC has proposed a change to 33% for the EOSTI remaining service time. This will provide additional escape time. The AHJ should do a needs assessment to determine which cylinder is appropriate for the application, taking into account the work time and escape time available.

1981-18 Log #11 FAE-RPE
(6.1.3)

Final Action: Reject

Submitter: Jeffrey O. Stull, International Personnel Protection, Inc.

Recommendation: Delete text as follows:

~~6.1.3 SCBA that are certified as compliant with NFPA 1981 shall also be certified by NIOSH as compliant with the Statement of Standard for NIOSH CBRN SCBA Testing.~~

Bring these requirements into the standard as new criteria and test methods.

Substantiation: The current arrangement for the testing of SCBA by NIOSH for CBRN is awkward. Per OMB Circular A119, the current criteria for CBRN testing for SCBA should become part of NFPA 1981. This would facilitate updating requirements, considering the use of surrogate agents, and other efficiencies that would lessen the costs of testing and allow for more frequent, consensus based reviews of the standard.

Committee Meeting Action: Reject

Committee Statement: OMB Circular A119 states "...this Circular directs agencies to use voluntary consensus standards in lieu of government-unique standards except where inconsistent with law...". NIOSH is the regulatory agency responsible for respiratory protection in the United States. The requirement for NIOSH certification must remain, as it has legal implications. Inclusion of the CBRN test methods into NFPA 1981 adds a potential failure point within the standard, as the technical committee has no oversight into changes in the NIOSH regulations. A change in NIOSH CBRN regulations could make NFPA 1981 certifications non-compliant with NIOSH. The potential use of chemical surrogates in place of chemical warfare agents has received a lot of attention. To evaluate the characteristics of a warfare agent with simulants will require a series of chemicals to replace each agent, which will increase the number of tests and therefore not necessarily improve efficiencies. The TC on Respiratory Protection Equipment will continue to provide standards which meet or exceed that required by law. The NFPA process ensures that frequent, consensus-based reviews will continue.

1981-19 Log #16 FAE-RPE
(6.2.3)

Final Action: Reject

Submitter: Christopher Langlois, Omaha Fire Dept. Training Bureau

Recommendation: Revise text to read as follows:

6.2.3 Each EOSTI shall meet the activation requirements of NIOSH certification as specified in 42 CFR 84.

Substantiation: The above 6.2.3 wording should not be changed. NIOSH 42 CFR 84.83 (f) states that the SCBA EOSTI activation should take place when the “remaining service life of the apparatus is reduced within a range of 20 to 25 percent of its rated service time”. We oppose changing the SCBA EOSTI activation level to any other level (i.e.: 33%, 50% or to be decided by the authority having jurisdiction). Please see the below reasons for opposition to changing the EOSTI.

Note: Supporting material is available for review at NFPA Headquarters.

This is not original material; its reference/source is as follows:

Information provided was developed by Capt. Chris Langlois and Capt. Dan Miller, Omaha Fire Dept. Training Bureau.

Committee Meeting Action: Reject

See Meeting Action on 1981-14 (Log #CP3).

Committee Statement: See Committee Statement on 1981-14 (Log #CP3). The technical committee invites the submitter to submit comments on this committee proposal.

1981-20 Log #CP8 FAE-RPE
(6.3.4)

Final Action: Accept

Submitter: Technical Committee on Respiratory Protection Equipment,

Recommendation: Revise text to read as follows:

6.3.4 Where HUD is provided with an external wiring disconnect, the wiring disconnect shall be designed to prevent accidental disconnection and shall not be capable of being connected in such a manner as to prevent the pneumatic system and the HUD from operating simultaneously.

Substantiation: The technical committee is proposing text adding requirements for connection of externally-wired HUDs to be modified to prevent improper connection.

Committee Meeting Action: Accept

1981-21 Log #6 FAE-RPE
(6.7 (New))

Final Action: Reject

Submitter: J. Roger Lackore, Pierce Manufacturing, Inc.

Recommendation: Add new text as follows:

6.7 Provisions for SCBA Retention in on an Apparatus

6.7.1 Each SCBA shall maintain an area clear of all obstructions forming a cylindrical area concentric with the bottle and one inch greater in radius than the bottle radius. For a cylinder with a dome shaped top this clear area shall begin 1 inch below the point where the spherical top of the bottle transitions into the cylindrical body of the bottle. For cylinders with flat tops, this clear area shall begin 2 inches below the top of the cylinder. This clear cylindrical area shall extend to 4 inches above the top of the bottle (see fig 1).

6.7.2 Each SCBA shall maintain a clear annular area concentric with the bottle, one inch greater in radius than the bottle radius, and 2 inches in height beginning at the back of the SCBA bottle and sweeping 160 degrees both clockwise and counterclockwise around the bottle. This clear annular area shall be located vertically on the bottle beginning on the plane at which the spherical top of the bottle transitions into the cylindrical body of the bottle, and extending downward (see fig 2). This area may overlap with the clear area specified in paragraph 6.7.1.

6.7.3 The bottle valve (or other lowest component) of each SCBA shall include a vertical surface with an area on the side of the bottle where the pack is mounted that is clear of obstructions for 1.5 inches up from the bottom of the component and for 0.5 inches from the valve (see fig 3).

6.7.4 Each SCBA pack shall be attached to the cylinder and constructed in such a manner that the SCBA can be extracted from a retention device that grips the cylinder with a maximum force of 80 lbs without damaging the pack for the expected life of the SCBA.

6.7.5 The SCBA bottle valve shall remain attached to the bottle without damage when a force of 20 times the weight of the bottle and pack is exerted at the CG of the SCBA for 10 seconds with the SCBA being held in two places, at the top of the bottle and at the extreme end of the valve.

Substantiation: SCBAs are commonly located inside the occupant area of fire or emergency vehicle apparatus. NFPA 1901 requires that such SCBAs be retained in a bracket to a minimum of 9 gs of deceleration to protect the occupants from the SCBA becoming a projectile in the event of a crash. SCBA retention bracket manufacturers struggle to design devices to adequately grip the bottle. The wide variety of SCBA pack designs, and the constant redesign of these products, makes it very difficult to ensure that a retention bracket will work with any SCBA manufactures product. This restricts inner-operability and places an undue burden on the fire service. This proposal establishes standards that would provide clear areas on each SCBA cylinder around which the SCBA retention device manufacturer can design universal products. It also establishes a minimum standard for SCBA pack durability when subjected to the repeated act of extracting the SCBA from a retention device that grips the cylinder to retain it in a device.

The 80 lb extraction force criteria is based on actual measurements of various SCBA holders on the market. As a base-line, the old "broom-clip" style bottle holders require 35 lb extraction force. This value also seems reasonable since the weight of the bottle and pack can weigh as much as 35 lbs, and the pack should survive continually pulling of at least twice its own weight so that it can last through the riggers of use at the fire scene.

The SCBA is commonly secured into the holder by gripping the bottle at the top, and the valve at the bottom. Although testing indicates that the typical bottle valve is more than strong enough to withstand the retention forces using this method of gripping, there does not appear to be any minimum valve strength criteria in the standard that would assure that future valves would always be strong enough to be treated in this manner without damage. The factor of 20 is well over the 9 g factor in 1901, but rather matches the FMVSS 207 seating systems. The logic being that if the seat should be held to the vehicle at 20 g, then the pack should be retained in the seat to 20 g.

Committee Meeting Action: Reject

Committee Statement: The proposal is design restrictive. It would prohibit using different pressure vessels other than those in the shape of a cylinder, and it would prohibit different SCBA designs. The bracket referred to in the proposal is not an issue within the scope of NFPA 1981.

1981-22 Log #7 FAE-RPE
(6.7 (New))

Final Action: Reject

Submitter: Roger Lackore, Pierce Mfg.

Recommendation: Add new text to read as follows:

6.7 Provisions for SCBA Retention in Fire Apparatus

6.7.1 Each SCBA shall maintain a space at the top of the bottle that is clear of all obstructions for retention devices that grab the top of the bottle. This space shall be bounded by a cylindrical volume concentric with the bottle and one inch greater in radius than the bottle radius. For a cylinder with a dome shaped top this clear area shall begin 1 inch below the point where the spherical top of the bottle transitions into the cylindrical body of the bottle (see fig. 1A). For a cylinder with a flat top, this clear volume shall begin 2 inches below the top of the cylinder (see fig. 1B). Each clear volume shall be preserved for at least 4 inches above the top of the bottle.

6.7.2 Each SCBA shall maintain a space near the top of the bottle that is clear of all obstructions for retention devices that grab around the body of the bottle. This space shall be bounded by an annular volume concentric with the bottle, 1.0 inch greater in radius than the bottle radius, and 2.0 inches in height beginning at the back of the SCBA bottle and sweeping 160 degrees both clockwise and counterclockwise around the bottle. For a cylinder with a dome shaped top this clear volume shall begin 1 inch below the point where the spherical top of the bottle transitions into the cylindrical body of the bottle (see fig. 2A). For a cylinder with a flat top, this clear volume shall begin 2 inches below the top of the cylinder (see fig. 2B). This volume may overlap with the volume specified in paragraph 6.7.1.

6.7.3 The bottle valve (or other lowest component) of each SCBA shall include a vertical surface with a volume on the side of the bottle where the pack is mounted that is clear of obstructions to accommodate a retention tab. This space shall be bounded by a rectangular prism that is 1.5 inches high beginning at the bottom of the valve, 0.5 inches deep from the face of the valve, and 3 inches in width centered on the valve (see fig 3).

6.7.4 Each SCBA pack shall be attached to the cylinder and constructed in such a manner that the SCBA can be extracted from a retention device with a force of 80 lbs without damaging the pack straps or frame for the expected life of the SCBA.

6.7.5 The SCBA bottle valve shall remain attached to the bottle without damage when a force of 20 times the weight of the bottle and pack is exerted at the CG of the SCBA for 10 seconds with the SCBA being retained by a fixture that grips the top of the bottle and the extreme end of the valve (see figure 4).

****Insert Artwork Here (6 pieces: Figures 1A, 1B, 2A, 2B, 3, 4)****

Substantiation: SCBAs are commonly located inside the occupant area of fire or emergency vehicle apparatus. NFPA 1901 requires that such SCBAs be retained in a bracket to a minimum of 9 gs of deceleration to protect the occupants from the SCBA becoming a projectile in the event of a crash. SCBA retention bracket manufacturers struggle to design devices to adequately grip the bottle. The wide variety of SCBA pack designs, and the constant redesign of these products, makes it very difficult to ensure that a retention bracket will work with all SCBA packs, frames and bottles. This restricts inner-operability and places an undue burden on the fire service. This proposal establishes standards that would provide clear spaces on each SCBA cylinder around which the SCBA retention device manufacturer can design universal products. It also establishes a minimum standard for SCBA pack durability when subjected to the repeated act of extracting the SCBA from a retention device that grips the cylinder to retain it in the holder.

The 80 lb extraction force criteria is based on actual measurements of various SCBA holders on the market. As a base-line, the old "broom-clip" style bottle holders require 35 lb extraction force. This value also seems reasonable since the weight of the bottle and pack can weigh as much as 35 lbs, and the pack should survive continually pulling of at least twice its own weight so that it can last through the riggers of use at the fire scene.

The SCBA is commonly secured into the holder by gripping the bottle at the top, and the valve at the bottom. Although testing indicates that the typical bottle valve is more than strong enough to withstand the retention forces using this method of gripping, there does not appear to be any minimum valve strength criteria in the standard. Acceptance of this proposal will assure that future valves would always be strong enough to be treated in this manner without damage. The 20 g factor matches the value used in FMVSS 207 for retention of seating systems. The logic for this value is that if the

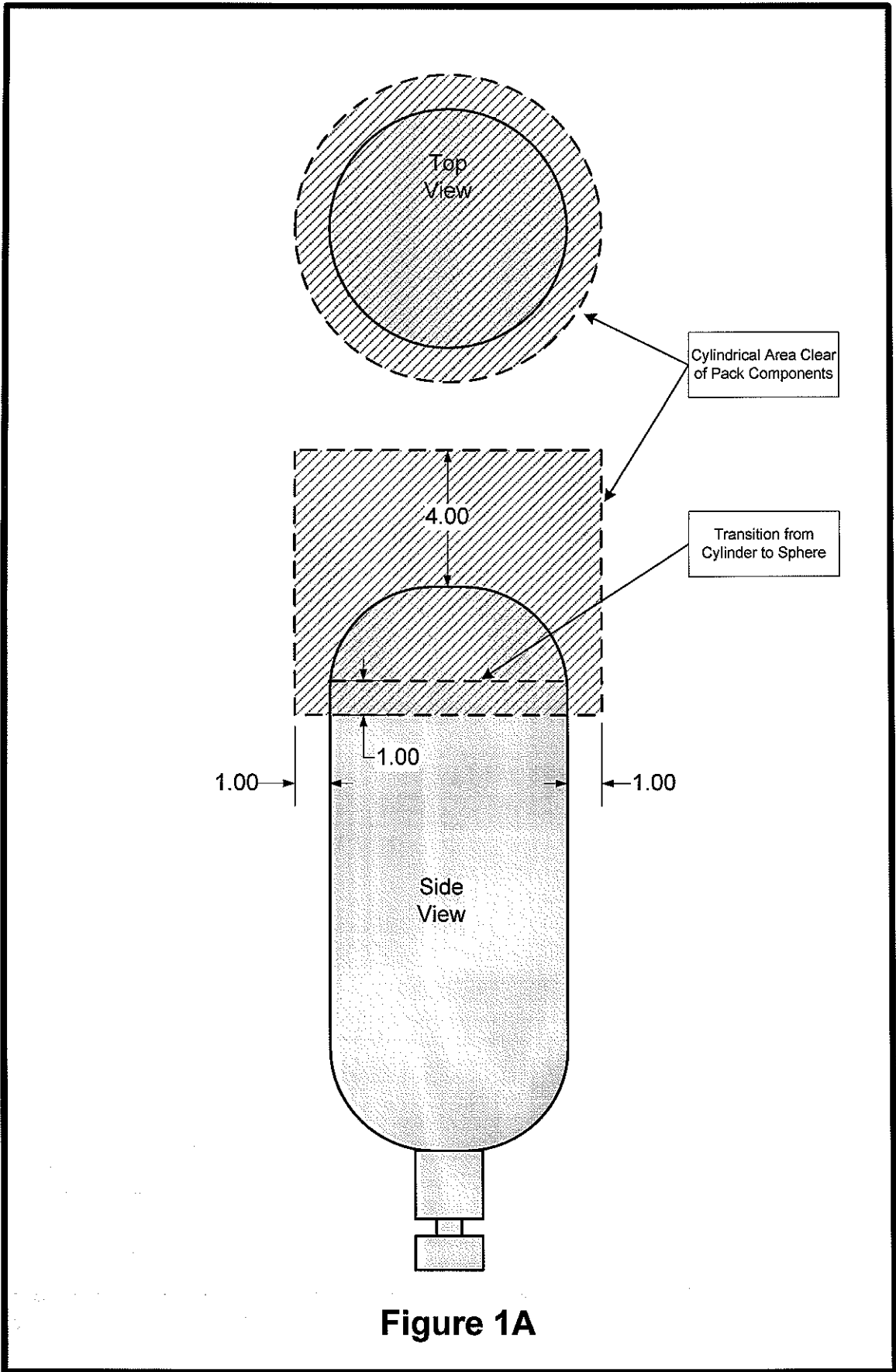

Figure 1A

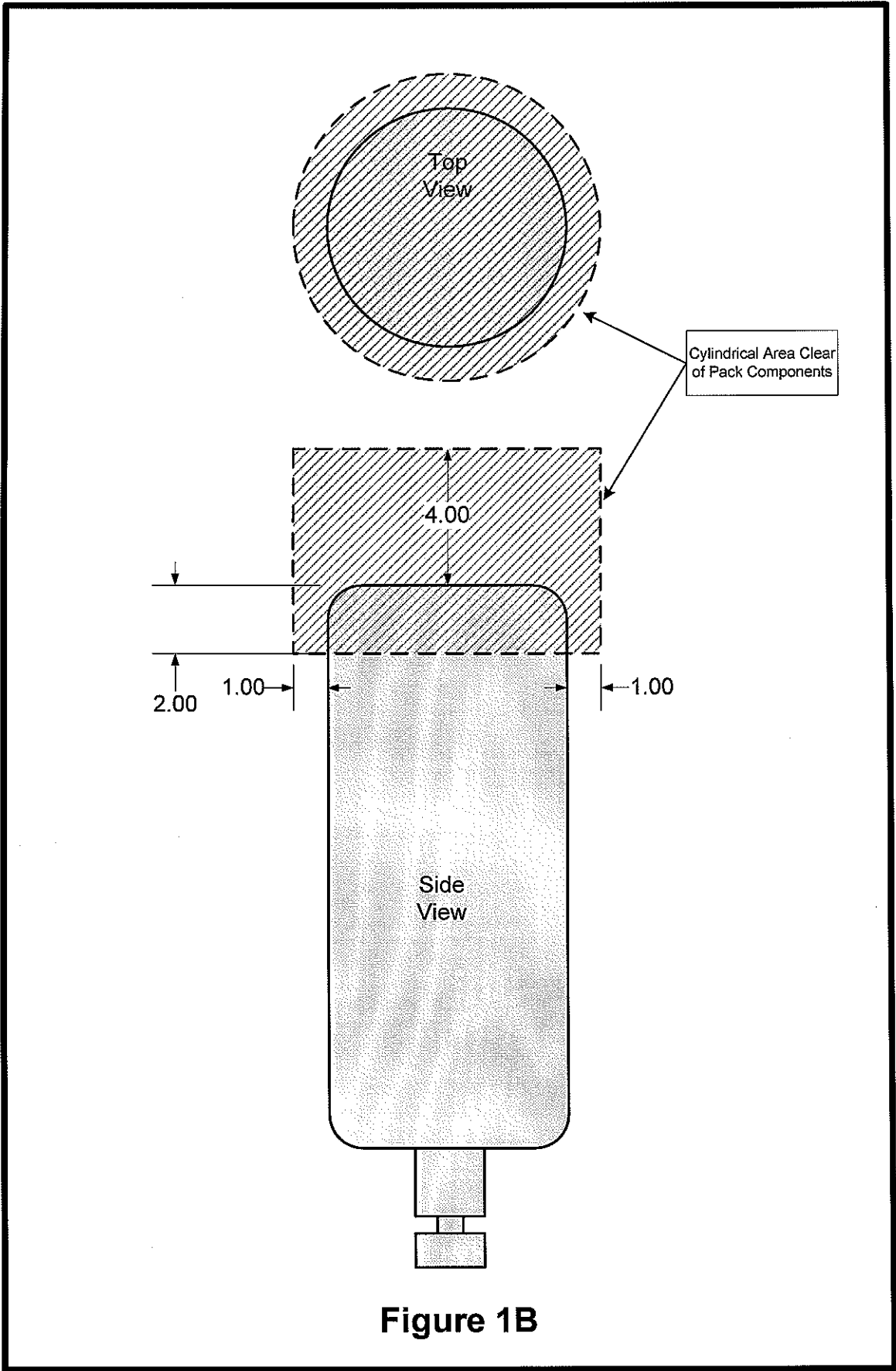

Figure 1B

1981, Log 7, Figures 1A, 1B, 2A, 2B, 3, 4

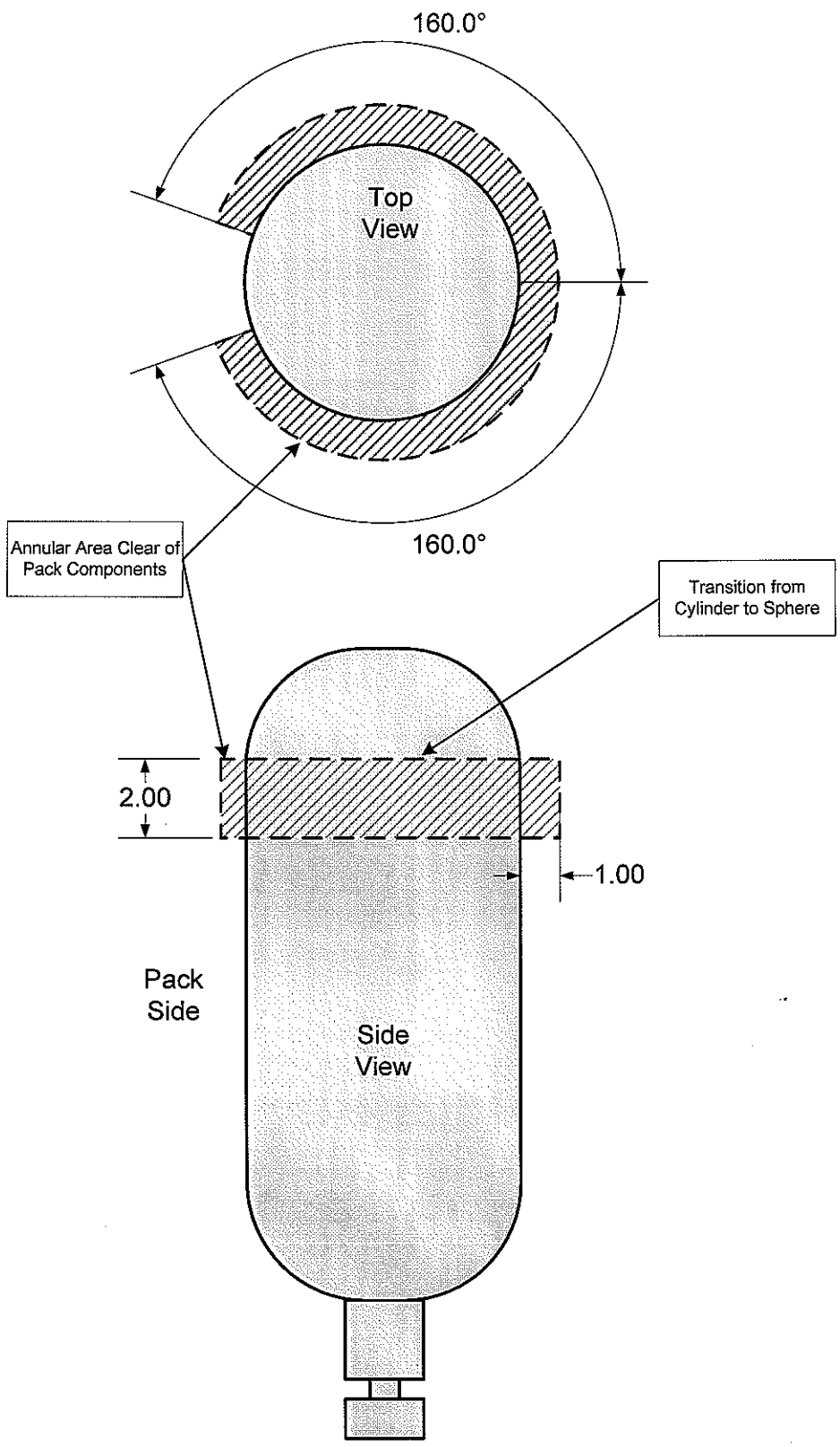

Figure 2A

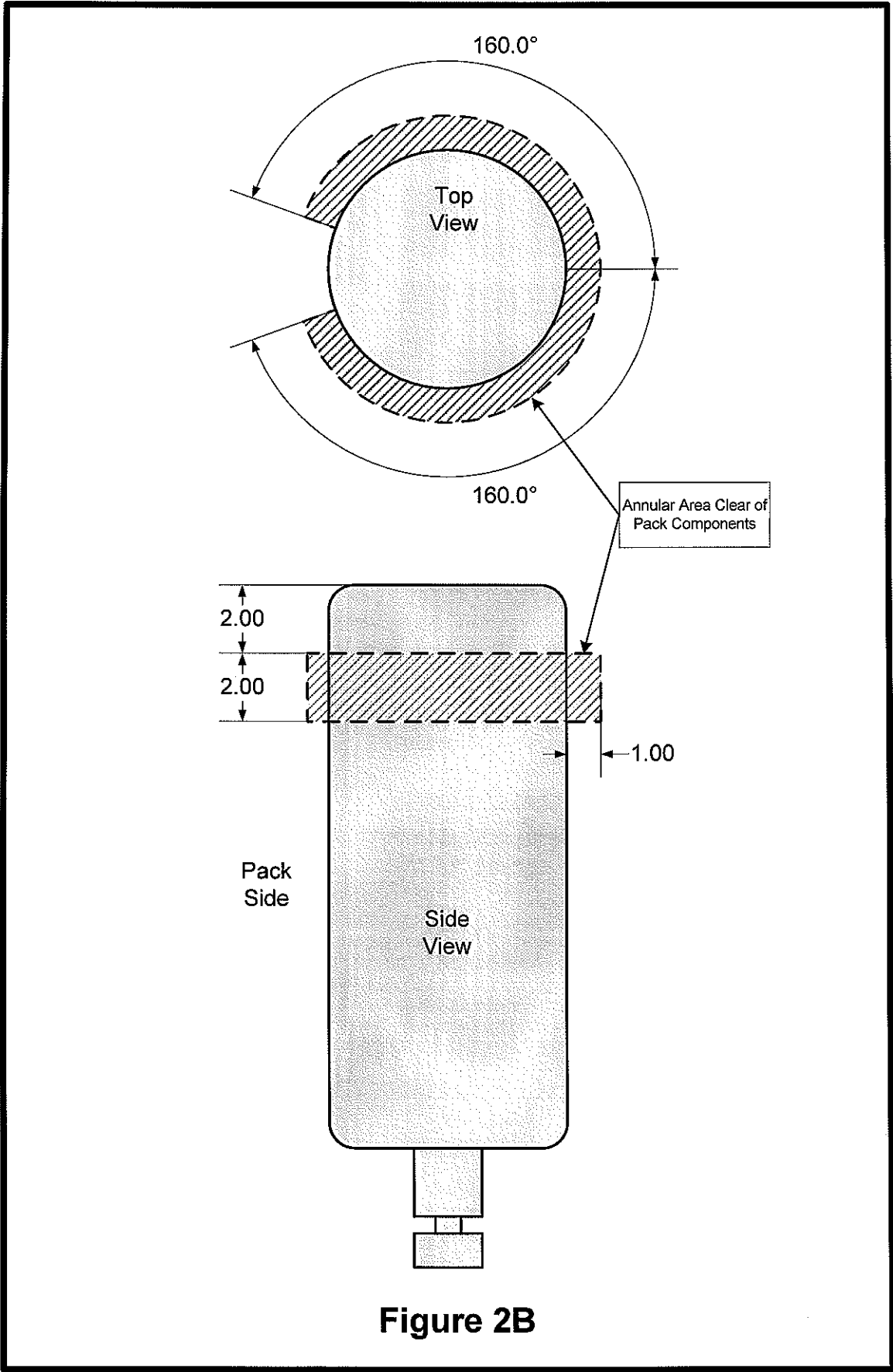

Figure 2B

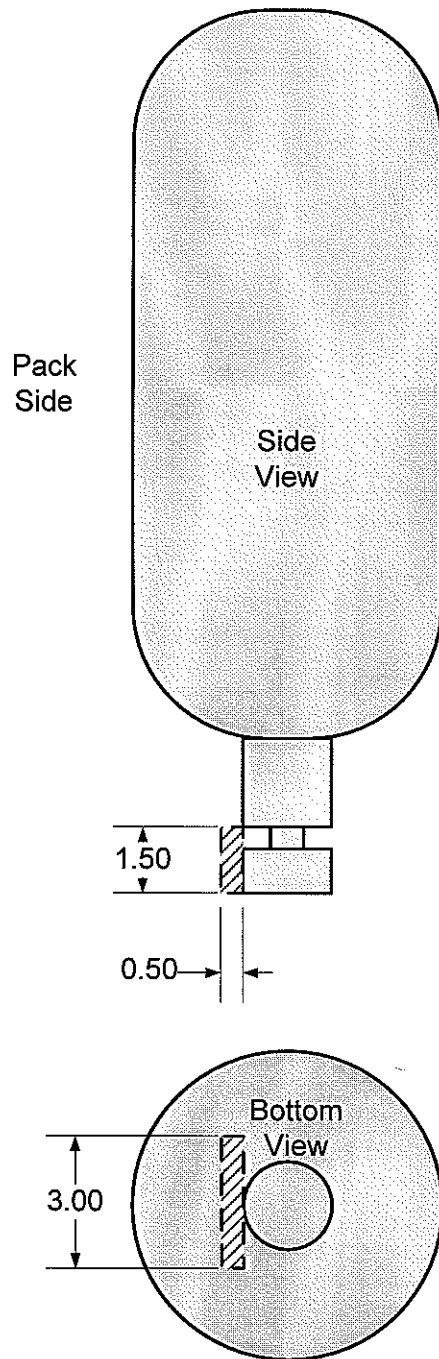

Figure 3

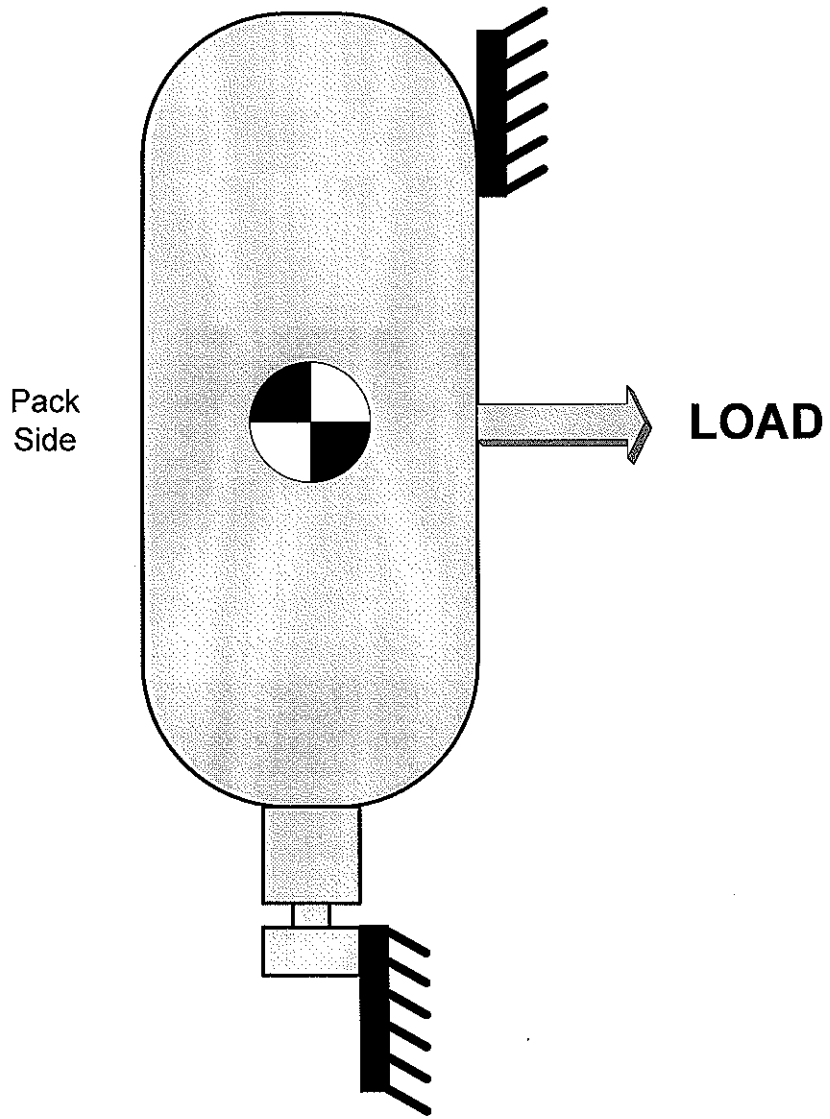

Figure 4

seat should be held to the vehicle at 20 g, then the pack should be retained in the seat to 20 g.

Committee Meeting Action: Reject

Committee Statement: The proposal is design restrictive. It would prohibit using different pressure vessels other than those in the shape of a cylinder, and it would prohibit different SCBA designs. The bracket referred to in the proposal is not an issue within the scope of NFPA 1981.

1981-23 Log #CP5 FAE-RPE
(7.21(New), 8.28 (New))

Final Action: Accept

Submitter: Technical Committee on Respiratory Protection Equipment,

Recommendation: Revise text to read as follows:

7.21 Lens Radiant Heat Resistance Performance.

7.21.1 SCBA shall be tested for lens radiant heat resistance as specified in Section 8.28. SCBA facepiece pressure shall not be less than 0.0 mm (0.0 in.) water column and shall not be greater than 89 mm (3½ in.) water column above ambient pressure from the time the test begins until the time the test is concluded.

7.21.2 The duration of the test as specified in 8.28 will be no less than 80% of the NIOSH-rated duration of the cylinder used.

8.28 Lens Radiant Heat Test.

8.28.1 Application. This test method shall apply to SCBA facepiece assemblies without installed accessories.

8.28.2 Samples. Each sample to be tested shall be as specified in 4.3.9.

8.28.3 Specimen Preparation.

8.28.3.1 Prior to testing, specimens shall be conditioned for a minimum of 4 hours and tested at an ambient temperature of 22°C, ±3°C (72°F, ±5°F) and RH of 50 percent, ±25 percent.

8.28.3.2 Specimens for conditioning shall be complete SCBA without installed accessories.

8.28.4 Apparatus.

8.28.4.1 A test headform meeting the requirements specified in 8.1.4.1 shall be provided.

8.28.4.2 The test headform shall be attached to the breathing machine as specified in Figure 8.1.4.9, with the modification that a 38 mm (1½ in.) I.D. breathing hose, not longer than 7.6 m (25 ft), shall be interconnected between the breathing machine and the throat tube of the test mannequin headform.

8.28.4.3 The test headform shall be covered with an undyed aramid hood for protection of the headform during testing.

8.28.4.3.1 The protective hood shall meet the hood requirements of NFPA 1971, *Standard on Protective Ensembles for Structural Fire Fighting and Proximity Fire Fighting*.

8.28.4.3.2 The protective hood, when placed on the test headform, shall not affect the seal of the facepiece to the headform.

8.28.4.3.3 The protective hood shall cover the facepiece retention system that holds the facepiece to the headform, the mask-mounted regulator and hoses, but not cover or protect any part of the facepiece lens.

8.28.4.4 The radiant heat test apparatus shall be as specified in *ASTM E162 Standard Test method for Surface Flammability of Materials Using a Radiant Heat Energy Source*, Section 6.1.1 and Fig. 1, without the inclusion of the Sheet Steel Stack.

8.28.4.5 A radiation shield shall be used to block radiant heat from the headform and facepiece before and after the test.

8.28.4.5.1 The radiation shield shall be at least 64 cm (25 in) wide by at least 56 cm (22 in) high, and be constructed of at least three layers of aluminum sheet separated by air gaps of 2 cm (0.8 in) with a black painted front side, or of similar design sufficient to block the radiant heat.

8.28.4.6 A heat flux transducer, water cooled, total heat flux sensor of Schmidt-Boelter type, with a viewing angle of 180° and a standard range of 0-20 kW/m², shall be used to measure the heat flux from the radiant heat test apparatus.

8.28.4.6.1 The heat flux transducer shall have been calibrated in the last 12 months.

8.28.4.6.2 The heat flux transducer shall be mounted so the face is vertical and parallel to the face of the radiant heat test apparatus.

8.28.4.6.3 The heat flux transducer shall be centered both horizontally and vertically with respect to the face of the radiant heat test apparatus.

8.28.5 Procedure.

8.28.5.1 The SCBA facepiece shall be mounted on the test headform to simulate the correct wearing position on a person as specified by the SCBA manufacturer's instructions.

8.28.5.2 The headform shall be positioned (at an angle if necessary) so that the vertical centerline of the facepiece lens is parallel with the face of the radiant heat test apparatus.

8.28.5.3.1 The headform shall be positioned so that the center of the facepiece lens is centered both horizontally and vertically with respect to face of the radiant heat test apparatus.

8.28.5.4 The radiant heat test apparatus shall be ignited and allowed to preheat and stabilize for a minimum of 45 minutes.

8.28.5.4.1 The air flow rate to the radiant heat test apparatus shall be set to 434 L/min, ±22 L/min (950 SCFH, ±50 SCFH).

8.28.5.4.2 The natural gas flow rate to the radiant heat test apparatus shall be set to 30 L/min, ±1.5 L/min (72 SCFH, ±4 SCFH).

8.28.5.4.3 During the conduct of the test, extraneous drafts shall be controlled by closing windows and doors, stopping air-circulating devices, and arranging baffles between the apparatus and any remaining sources of drafts.

8.28.5.5 To calibrate the radiant heat apparatus, the heat flux transducer shall be moved in front of the radiant heat test apparatus to a location where the heat flux transducer measures $15 \text{ kW/m}^2 \pm 0.5 \text{ kW/m}^2$ for 5 minutes.

8.28.5.5.1 The output voltage from the heat flux transducer shall be sampled at a minimum rate of 1 Hz by a data acquisition system, which has a minimum resolution of 1 part in 4096 of full scale (0.02%).

8.28.5.5.2 The output voltage shall be converted to units of heat flux using the most recent calibration coefficients.

8.28.5.5.3 The heat flux transducer shall be water cooled with 0.4 L/min – 0.8 L/min (0.1 gal/min – 0.2 gal/min) of water at 16°C – 30°C (61°F – 86°F), such that the exit temperature of the water does not vary more than ±2°C (4°F) during the test.

8.28.5.5.3 The horizontal distance from the radiant heat test apparatus to the face of the heat flux transducer shall be located and marked.

8.28.5.5.5 The heat flux transducer shall be removed from exposure to the radiant test apparatus.

8.28.5.6 After the radiant heat test apparatus has been preheated and has a calibration mark for 15 kW/m^2 , the radiation shield shall be positioned in front of the radiant heat test apparatus.

8.28.5.7 The SCBA facepiece mounted on the test headform at the appropriate angle as described in 8.28.5.3 shall be placed behind the radiation shield.

8.28.5.8 The airflow performance test shall be conducted as specified in 8.1.5, and with the heat flux specified in 8.28.5.5.

8.28.5.9 The airflow performance test shall begin no longer than 30 s before the SCBA facepiece is exposed to the radiant heat apparatus and shall continue for a total duration of 15 min.

8.28.5.10 The ventilation rate shall be set at 40 L/min, ±2 L/min, with a respiratory frequency of 24 breaths/min, ±1 breath/min at ambient conditions as specified in 8.1.3.2.

8.28.5.11 The radiation shield shall be removed, and the headform shall be moved towards the radiant heat apparatus, within 5 seconds of shield removal, so that vertical front face of the facepiece lens is lined up with the calibration mark for 15 kW/m^2 .

8.28.5.12 After the test headform is placed in the position specified in 8.28.5.9.1, the test exposure time of 5 minutes +2.0 seconds /- 0.0 seconds shall begin.

8.28.5.13 At the completion of the 5-minute exposure, the headform shall be moved away from the radiant heat test apparatus, and the radiation shield will be placed between the radiant heat test apparatus and the headform.

8.28.5.14 Within 15 seconds after the radiant heat exposure has been completed, the test headform shall be raised 150 mm, +6 mm/-0 mm (6 in., +¼ in./-0 in.) and dropped freely.

8.28.5.15 The facepiece pressure during the entire test shall be read from the strip chart recorder to determine pass or fail as specified in 7.21.1.

8.28.5.16 Any pressure spike caused by the impact of the drop test and measured within a duration of three cycles of the breathing machine after the apparatus drop shall be disregarded.

8.28.6 Report.

8.28.6.1 The facepiece pressure peak inhalation and peak exhalation shall be recorded and reported for each test condition.

8.28.7 Interpretation.

8.28.7.1 Pass or fail performance shall be based on the facepiece pressure peak inhalation and exhalation values for the duration of the test.

8.28.7.2 Failure to meet any of the test condition requirements shall constitute failure of the SCBA.

Substantiation: The NFPA Respiratory Protective Equipment Committee became aware of a number of fire incidents involving injury & fatalities where the self contained breathing apparatus (SCBA) face piece lens was thermally degraded while the fire fighters were likely still on air.

The National Institute of Occupational Safety and Health (NIOSH) Fire Fighter Fatality and Injury Prevention Program (FFFIPP) investigation results were communicated to the technical committee and a committee task group was established and with the assistance of a number of agencies, users, & manufacturers developed a test procedure to challenge the SCBA face piece lens. With the assistance of National Institute of Standards & Technology (NIST), thermal exposure tests, Lens Radiant Panel Heat Test and Lens Convection Heat and Flame Resistance Test, were developed and brought to the full committee for consideration.

The task group developed two lens tests that would mimic and address the likely conditions experienced by fire fighters during fire operations. The two tests address both the radiant thermal exposure and the convective heat exposure of SCBA lens. The task group presented both tests to the full committee and the full committee agreed that both tests should be added to NFPA 1981 standard to supplement the existing heat and flame test.

Committee Meeting Action: Accept

1981-24 Log #CP6 FAE-RPE
(7.22 (New), 8.29 (New))

Final Action: Accept

Submitter: Technical Committee on Respiratory Protection Equipment,

Recommendation: Revise text to read as follows:

7.22 Convection Lens Heat and Flame Resistance Performance Requirements.

7.22.1 SCBA shall be tested for lens heat and flame resistance as specified in Section 8.29. SCBA facepiece pressure shall not be less than 0.0 mm (0.0 in.) water column and shall not be greater than 89 mm (3½ in.) water column above ambient pressure from the time the test begins until the time the test is concluded.

7.22.2 The duration of the test as specified in 8.29 will be no less than 80% of the NIOSH-rated duration of the cylinder used.

8.29 Lens Convective Heat and Flame Resistance Test.

8.29.1 Application. This test method shall apply to complete SCBA.

8.29.2 Samples. Each sample to be tested shall be as specified in 4.3.9.

8.29.3 Specimen Preparation.

8.29.3.1 Prior to testing, specimens shall be conditioned for a minimum of 4 hours and tested at an ambient temperature of 22°C, ±3°C (72°F, ±5°F) and RH of 50 percent, ±25 percent.

8.29.3.2 Specimens for conditioning shall be complete SCBA.

8.29.4 Apparatus.

8.29.4.1 A test mannequin meeting the requirements specified in Figure 8.29.4.1 shall be provided.

INSERT Figure 8.29.4.1 Test Mannequin (Current Edition, Figure 8.11.4.1, not being shown)

8.29.4.2 Both the calibration mannequin and the heat and flame test mannequin shall have protective coverings.

8.29.4.2.1 The protective coverings shall be a weld blanket made of fireproof silica cloth of a minimum weight of 18 oz/sq yd.

8.29.4.2.2 The protective coverings shall be designed and constructed to provide coverage over the surface of the mannequins.

8.29.4.2.3 Where additional insulation is needed to protect the mannequin electronics, an additional thermal liner underlayer shall be permitted.

8.29.4.2.4 The complete protective covering shall be discarded and shall not be used where the damage to any portion indicates the covering can no longer provide thermal protection for the test mannequin.

8.29.4.3 A test headform meeting the requirements specified in 8.1.4.1 shall be used on the test mannequin.

8.29.4.4 The test headform shall be attached to the breathing machine as specified in Figure 8.1.4.9, with the modification that a 38 mm (1½ in.) I.D. breathing hose, not longer than 7.6 m (25 ft), shall be interconnected between the breathing machine and the throat tube of the test mannequin headform.

8.29.4.5 The test headform shall be covered with an undyed aramid hood for protection of the headform during testing.

8.29.4.5.1 The protective hood shall meet the hood requirements of NFPA 1971, *Standard on Protective Ensembles for Structural Fire Fighting and Proximity Fire Fighting*.

8.29.4.5.2 The protective hood, when placed on the test headform, shall not affect the seal of the facepiece to the headform.

8.29.4.5.3 The protective hood shall not cover or protect any part of the facepiece or the facepiece retention system that holds the facepiece to the headform.

8.29.4.6 The heat and flame test apparatus shall be as specified in Figure 8.29.4.6.

Insert Figure 8.29.4.6 Heat and Flame Test Apparatus (current Figure 8.11.4.6, not being shown)

8.29.4.6.1 The test oven shall be a horizontal forced circulating air oven with a range of flow of 38 m/min to 76 m/min (125 ft/min to 250 ft/min).

8.29.4.6.2 The test oven shall have minimum dimensions of 915 mm depth × 915 mm width × 1.22 m height (36 in. depth × 36 in. width × 48 in. height).

8.29.5 Procedure.

8.29.5.1 The SCBA shall be mounted on the test mannequin to simulate the correct wearing position on a person as specified by the SCBA manufacturer's instructions.

8.29.5.2 The facepiece shall be mounted and tested on the test headform as specified in 8.1.4.1.

8.29.5.3 For calibration prior to the heat and flame test, the mannequin for calibration shall be the same as the test mannequin specified in 8.29.4.1 and shall be exposed to direct flame contact for 10 seconds using the heat and flame test apparatus.

8.29.5.3.1 All peak temperature readings shall be within a temperature range of 815°C to 1150°C (1500°F to 2102°F).

8.29.5.3.2 The average mean of all peak temperature readings specified in 8.29.5.3.1 shall be no higher than 950°C (1742°F).

8.29.5.4 The test oven recovery time, after the door is closed, shall not exceed 1.0 minute.

8.29.5.5 The airflow performance test shall be conducted as specified in 8.1.5, with modifications to the ventilation rate specified in 8.29.5.7 with the test temperatures specified in 8.29.5.3 and 8.29.5.8.

8.29.5.5.1 The variation in pressure extremes caused by the heat and flame test mannequin configuration shall be determined as specified in 8.29.5.5.2 and 8.29.5.5.3.

8.29.5.5.2 The airflow performance test as specified in Section 8.1, Airflow Performance Test, shall be carried out using the configuration specified in 8.29.4.4.

8.29.5.5.3 The difference in pressure between the two tests shall be calculated by subtracting the values obtained using the configuration defined in 8.29.4.4 from the values obtained using the configuration specified in Section 8.1, Airflow Performance Test.

8.29.5.6 The airflow performance test shall begin no longer than 60 s before the SCBA and mannequin are placed into the oven with the door closed and shall continue for a total duration of 24 min.

8.29.5.7 The ventilation rate shall be set at 40 L/min, ±2 L/min, with a respiratory frequency of 24 breaths/min, ±1 breath/min at ambient conditions as specified in 8.1.3.2.

8.29.5.8 The SCBA mounted on the test mannequin shall be placed in the test oven at a temperature of 260°C, ±5°C (500°F, ±10°F).

8.29.5.9 After the test oven door is closed and the oven temperature recovers to 260°C, ±5°C (500°F, ±10°F), the test exposure time of 5 minutes +2.0 seconds/- 0.0 seconds shall begin. Recovery time shall be less than 60 seconds.

8.29.5.10 At the completion of the 5-minute exposure, the oven door shall be opened, and the SCBA mounted on the test mannequin shall be moved out of the oven and into the center of the burner array.

8.29.5.12 The SCBA shall then be exposed to direct flame contact for 10 seconds, +0.25 second/-0.0 seconds.

8.29.5.13 This exposure shall begin within 20 seconds of removal of the SCBA from the test oven.

8.29.5.14 The SCBA shall be observed for any afterflame, and the afterflame shall be extinguished with a spray-type device using room temperature water.

8.29.5.15 Within 20 seconds after the direct flame exposure has been completed, the SCBA mounted on the test mannequin shall be raised 150 mm, +6 mm/-0 mm (6 in., +¼ in./-0 in.) and dropped freely.

8.29.5.16 The facepiece pressure during the entire test shall be read from the strip chart recorder and corrected by adding the value of the difference in pressure calculated in 8.29.5.5.1 to determine pass or fail as specified in 7.22.1.

8.29.5.17 Any pressure spike caused by the impact of the drop test and measured within a duration of three cycles of the breathing machine after the apparatus drop shall be disregarded.

8.29.6 Report.

8.29.6.1 The facepiece pressure peak inhalation and peak exhalation shall be recorded and reported for each test condition.

8.29.7 Interpretation.

8.29.7.1 Pass or fail performance shall be based on the facepiece pressure peak inhalation and exhalation values for the duration of the test.

8.29.7.2 Failure to meet any of the test condition requirements shall constitute failure of the SCBA.

Substantiation: The NFPA Respiratory Protective Equipment Committee became aware of a number of fire incidents involving injury & fatalities where the self contained breathing apparatus (SCBA) face piece lens was thermally degraded while the fire fighters were likely still on air.

The National Institute of Occupational Safety and Health (NIOSH) Fire Fighter Fatality and Injury Prevention Program (FFFIPP) investigation results were communicated to the technical committee and a committee task group was established and with the assistance of a number of agencies, users, & manufacturers developed a test procedure to challenge the SCBA face piece lens. With the assistance of National Institute of Standards & Technology (NIST), thermal exposure tests, Lens Radiant Panel Heat Test and Lens Convection Heat and Flame Resistance Test, were developed and brought to the full committee for consideration.

The task group developed two lens tests that would mimic and address the likely conditions experienced by fire fighters during fire operations. The two tests address both the radiant thermal exposure and the convective heat exposure of SCBA lens. The task group presented both tests to the full committee and the full committee agreed that both tests

should be added to NFPA 1981 standard to supplement the existing heat and flame test.

Committee Meeting Action: Accept

1981-25 Log #18 FAE-RPE
(8.1.4.8.1 (New))

Final Action: Accept in Principle

Submitter: Bill Parson, Scott Safety

Recommendation: Add text to read as follows:

8.1.4.8.1 Air exhaled thru the headform shall be conditioned to an average temperature of 80+-10 degrees F / 27+-12 Degrees C when measured at the breathing passage outlet at the mouth of the test headform.

Substantiation: By making the breathing simulator better replicate human respiration the test will better reflect the performance of the respirator in actual use.

The mechanical breathing simulator significantly differs from actual measured respiration temperatures due to natural heat exchange in the human respiratory tract.

Design decisions maybe made to optimize respirator performance for breathing simulators rather than for human use.

This addition will allow the breathing simulator to better replicate actual human use.

Committee Meeting Action: Accept in Principle

Add new text to read as follows:

8.1.4.8.1 Air exhaled thru the headform shall be conditioned to an average temperature of 80 +-10 degrees F (27+-6 degrees C) when measured at the breathing passage outlet at the mouth of the test headform.

Committee Statement: The technical committee accepted the proposal in principle, and changed the ± degrees C from 12 to 6.

1981-26 Log #CP7 FAE-RPE
(8.3.4.2.3 (New))

Final Action: Accept

Submitter: Technical Committee on Respiratory Protection Equipment,

Recommendation: Add a new paragraph as follows:

8.3.4.2.3 If a different geometry of pressure vessels are used compared to the standard industry cylinder construction, the compartments shall be designed to accommodate the size and shape of the different pressure vessel, allowing a clearance of 150 mm (6 in.) between the pressure vessel and all sides of the compartment.

Substantiation: The current vibration compartments cannot accommodate different pressure vessel sizes and shapes that are not of the conventional design.

Committee Meeting Action: Accept