

Report of the Committee on**Lightning Protection****John M. Tobias, Chair**

US Department of the Army, NJ [U]

Gerard M. Berger, CNRS - Supelec, France [SE]
Matthew Caie, ERICO, Inc., OH [M]
Josephine Covino, US Department of Defense, VA [E]
Ignacio T. Cruz, Cruz Associates, Inc., VA [SE]
Robert F. Daley, US Department of Energy, NM [U]
Joseph P. DeGregoria, Underwriters Laboratories Inc., NY [RT]
Douglas J. Franklin, Thompson Lightning Protection Inc., MN [M]
William Goldbach, Danaher Power Solutions, VA [M]
Mitchell Guthrie, Consulting Engineer, NC [SE]
Thomas R. Harger, Harger Lightning Protection Inc., IL [M]
William E. Heary, Lightning Preventors of America Inc., NY [IM]
Bruce A. Kaiser, Lightning Master Corporation, FL [M]
Joseph A. Lanzoni, Lightning Eliminators & Consultants Inc., CO [M]
Eduardo Mariani, CIMA Ingenieria SRL, Argentina [SE]
David E. McAfee, Fire and Lightning Consultants, TN [SE]
Robley B. Melton, Jr., CSI Telecommunications, GA [U]
 Rep. Alliance for Telecommunications Industry Solutions
Victor Minak, ExxonMobil Research & Engineering Company, VA [U]
 Rep. American Petroleum Institute
Mark P. Morgan, East Coast Lightning Equipment, Inc., CT [M]
Terrance K. Portfleet, Michigan Lightning Protection Inc., MI [IM]
 Rep. United Lightning Protection Association, Inc.
Vladimir A. Rakov, University of Florida, FL [SE]
Robert W. Rapp, National Lightning Protection Corporation, CO [M]
Dick Reehl, Qwest Communications, WA [U]
William Rison, New Mexico Institute of Mining & Technology, NM [SE]
Lon D. Santis, Institute of Makers of Explosives, DC [U]
 Rep. Institute of Makers of Explosives
Larry W. Strother, US Air Force, FL [E]
Harold VanSickle, III, Lightning Protection Institute, MO [IM]
 Rep. Lightning Protection Institute
Charles L. Wakefield, US Department of the Navy, MD [E]
Donald W. Zipse, Zipse Electrical Engineering Inc., PA [U]
 Rep. Institute of Electrical & Electronics Engineers, Inc.

Alternates

Charles H. Ackerman, East Coast Lightning Equipment Inc., CT [M]
 (Alt. to Mark P. Morgan)
Richard W. Bouchard, Underwriters Laboratories Inc., CO [RT]
 (Alt. to Joseph P. DeGregoria)
Peter A. Carpenter, Lightning Eliminators & Consultants Inc., CO [M]
 (Alt. to Joseph A. Lanzoni)
Franco D'Alessandro, ERICO, Inc., OH [M]
 (Alt. to Matthew Caie)
Dennis P. Dillon, Bonded Lightning Protection, Inc., FL [IM]
 (Alt. to Harold VanSickle, III)
Dennis Dyl, Kragh Engineering Inc., IL [SE]
 (Voting Alt. to Kragh Rep.)
Mark S. Harger, Harger Lightning & Grounding, IL [M]
 (Alt. to Thomas R. Harger)
Kenneth P. Heary, Lightning Preventor of America Inc., NY [IM]
 (Alt. to William E. Heary)
Stephen Humeniuk, Warren Lightning Rod Company, NJ [IM]
 (Alt. to Terrance K. Portfleet)
Christopher R. Karabin, US Department of the Navy, MD [E]
 (Alt. to Charles L. Wakefield)
David John Leidel, Halliburton Energy Services, TX [U]
 (Alt. to Lon D. Santis)
Charles B. Moore, New Mexico Institute of Mining & Technology, NM [SE]
 (Alt. to William Rison)
Melvin K. Sanders, Things Electrical Co., Inc. (TECo., Inc.), IA [U]
 (Alt. to Donald W. Zipse)
Allan P. Steffes, Thompson Lightning Protection Inc., MN [M]
 (Alt. to Douglas J. Franklin)
Paul R. Svendsen, National Lightning Protection Corporation, CO [M]
 (Alt. to Robert W. Rapp)

Staff Liaison: **Richard J. Roux**

Committee Scope: This Committee shall have primary responsibility for documents on the protection from lightning of buildings and structures, recreation and sports areas, and any other situations involving danger from lightning to people or property, except those concepts utilizing early streamer emission air terminals. The protection of electric generating, transmission, and distribution systems is not within the scope of this Committee.

This list represents the membership at the time the Committee was balloted on the text of this edition. Since that time, changes in the membership may have occurred. A key to classifications is found at the front of this book.

This portion of the Technical Committee Report of the Committee on **Lightning Protection** is presented for adoption.

This Report on Comments was prepared by the **Technical Committee on Lightning Protection**, and documents its action on the comments received on its Report on Proposals on NFPA 780, **Standard on Lightning Protection**, 2004 edition, as published in the Report on Proposals for the 2007 June Meeting.

This Report on Comments has been submitted to letter ballot of the **Technical Committee on Lightning Protection**, which consists of 30 voting members. The results of the balloting, after circulation of any negative votes, can be found in the report.

**780-1 Log #5 Final Action: Reject
(Entire Document)****Submitter:** Matthew Caie, ERICO, Inc.**Comment on Proposal No:** 780-35**Recommendation:** Reconsider Proposal 780-35.

Substantiation: This proposal was rejected on the basis that the placement of air terminals at a distance of up to 2 ft from a likely strike point on a structure “has not caused any problems”. However, No substantiation was provided to back this claim, e.g., the types and heights of buildings, the lightning activity in the regions supposedly identified, quantitative results of field studies, etc. If a proper field survey is carried out and examples are found where the 2 ft distance is, as suspected, too large in high lightning areas and on taller structures, the whole issue would need to be re-opened. A quantitative study was carried out recently [1] and presented in three different international forums. It showed that a fixed 2 ft rule is not appropriate and for short rods, like the ones typically installed in the USA (10 in. or 12 in. length), the 2 ft rule is much too loose for protecting vulnerable points on structures. The study also showed that the maximum distance is dependent on the height of air terminal that is installed. Furthermore, if one considers what is recommended in other international standards such as the IEC, 10 in. and 12 in. rods would need to be installed much closer than the allowable 2 ft distance. For example, IEC62305-3 shows that the “protection angle method” can be used in this situation for structures up to 200 ft in height. Appendix E, Figure E.12, clearly shows that if a rod is positioned near an edge or corner of a building, the height of the rod and the building are applied in the normative Table 2 of the standard. Taking a 10” rod as an example, the maximum distance from the edge or corner of the structure that is allowable for structure heights in the range 16–200 ft is 2.2 – 0.35 ft. This range is based on Level III protection, which is essentially equivalent to the single protection level used in NFPA 780 (150 ft rolling ball etc.). From [1], the recommended maximum distance for 10 in. rods on a 165 ft building is 0.27 ft, in good agreement with the value determined from the IEC standard. So, the question remains – what is the basis or justification for the 2 ft rule in NFPA 780 and the reason to reject a rigorous quantitative analysis that agrees with the IEC standard?

Committee Meeting Action: Reject**Committee Statement:** See Committee Action and Statement on 780-15 (Log #8).**Number Eligible to Vote: 30****Ballot Results:** Affirmative: 24 Negative: 1 Abstain: 1**Ballot Not Returned:** 4 Dyl, D., Heary, W., Rapp, R., Reehl, D.**Explanation of Negative:**

GUTHRIE, M.: Committee action indicates that the proposal is rejected but the action taken on ROC 780-15 reconsidered ROP 780-35 as requested by the submitter and made changes that would appear to meet the intent of the submitter. The action taken should be changed to “Accept in Principle” with the committee statement the same as existing.

Explanation of Abstention:

KAISER, B.: Due to travel problems, I was unable to attend the 780 meeting. Without benefit of the discussions, I do not believe I have the necessary background and therefore do not feel comfortable voting on the Committee Actions.

**780-2 Log #37 Final Action: Accept
(Entire Document)****Submitter:** Melvin K. Sanders, Ankeny, IA**Comment on Proposal No:** 780-1**Recommendation:** In the Committee action to “Accept in Principle” in C.2.1, the formula in parenthetical brackets should be rewritten as follows:(voltage = current times resistance)**Substantiation:** This change will correctly reflect the mathematical formulae symbols of “ $V = I \times R$ ”**Committee Meeting Action: Accept****Number Eligible to Vote: 30****Ballot Results:** Affirmative: 25 Abstain: 1**Ballot Not Returned:** 4 Dyl, D., Heary, W., Rapp, R., Reehl, D.**Explanation of Abstention:**

KAISER, B.: See My Explanation of Abstention on 780-1 (Log #5).

**780-2a Log #CC1 Final Action: Accept
(Entire Document)****Submitter:** Technical Committee on Lightning Protection,**Comment on Proposal No:** 780-1**Recommendation:** In 4.7.3, change “Rolling Sphere Model.” to “Rolling Sphere Method.”

In 4.7.3.1(C), change “rolling sphere model” to “rolling sphere method.”

In 4.7.3.3 (draft), change “rolling sphere model” to “rolling sphere method.”

In 4.7.3.4, change “rolling sphere model” to “rolling sphere method.”

In 4.8.2.4, change “rolling sphere model” to “rolling sphere method.”

Substantiation: The committee intends to ensure consistency of terms of “rolling sphere model” and “rolling sphere method.” “Rolling sphere method” is preferred.**Committee Meeting Action: Accept****Number Eligible to Vote: 30****Ballot Results:** Affirmative: 25 Abstain: 1**Ballot Not Returned:** 4 Dyl, D., Heary, W., Rapp, R., Reehl, D.**Explanation of Abstention:**

KAISER, B.: See My Explanation of Abstention on 780-1 (Log #5).

**780-3 Log #28 Final Action: Accept
(3.3.3 Chimney)****Submitter:** Mitchell Guthrie, Blanch, NC**Comment on Proposal No:** 780-4**Recommendation:** It is recommended that the definition for chimney be revised as follows:

3.3.3 Chimney. A construction containing one or more flues that does not meet the criteria defined for Heavy-Duty Stack.

Substantiation: Based on the wording of the definition of “Heavy-Duty Stack,” it is agreed that the original intent of the definition of chimney is that it is the flue for which the cross-sectional area is defined. Upon reviewing the document for the definitions and usage of the terms “chimney” and “heavy duty stack,” it is clear that the purpose of the definition is to identify that the term “chimney” (as used in the document) refers to items containing a flue that do not meet the requirements of a “heavy-duty stack.” I believe that it would be much clearer to the user of the document if we simply stated such. Otherwise, how is one to deal with those cases such as shown in Figure 4.8.8.3 where a chimney contains multiple flues? Do we add the cross-sectional area of the flues or use only one (maybe the largest if they are different sizes)?

If it is primarily height that is the key factor, why not delete the cross-section of the flue from the definition of the two terms? Is it a practical design to have a “chimney” over 75 feet high with a flue cross sectional area of less than 500 square inches?

Committee Meeting Action: Accept**Number Eligible to Vote: 30****Ballot Results:** Affirmative: 25 Abstain: 1**Ballot Not Returned:** 4 Dyl, D., Heary, W., Rapp, R., Reehl, D.**Explanation of Abstention:**

KAISER, B.: See My Explanation of Abstention on 780-1 (Log #5).

**780-4 Log #22 Final Action: Accept in Principle in Part
(4.9.3.1)****Submitter:** Mitchell Guthrie, Blanch, NC**Comment on Proposal No:** 780-44a**Recommendation:** Delete Clause 4.9.3.2 and retain “ladders” in existing Clause 4.9.3.1.

Substantiation: It is agreed that the actions taken on ROP 780-44a will resolve the conflict between Clauses 4.9.3.1 and 4.9.3.2. However, I feel that the safest alternative was not chosen. The decision to allow the substitution of handrails and ladders for required conductors will lead to an increased level of touch potential from the one conductor that humans may be most likely exposed and that is likely to be expected to carry the greater percentage of lightning current among the down conductors. The action taken in ROP 780-44a will by design eliminate any alternative current path in the vicinity of the ladder or handrail that may act to limit the touch potential on the ladder or handrail.

NFPA 780-2004, M.2.1 suggests that one should not remain out-of-doors during lightning activity but should instead seek shelter in a building protected against lightning. Based on a risk assessment in accordance with IEC 62305-2, this suggestion may lead to a greater risk of human injury than if one were to remain in an open field if the primary entrance point into the structure uses a hand rail used as a down conductor as per the proposal and the structure is struck at the time the person is transiting into the structure. There is a greater probability of the structure being struck than an isolated person. There is currently an incident in litigation in France where a person was killed when exiting a tower (with metal steps and handrails).

“IEC 62305 – Protection against Lightning, Part 3: Physical damage to structures and life hazard” indicates in Section 8.1 that people in the vicinity of a down conductor can be exposed to an unnecessary life hazard if the exposure to a down conductor is not kept to a minimum. The use of a ladder or handrail as a down conductor is clearly not a method that would minimize the exposure of people to the down conductors. Where exposure to down conductors cannot be reduced to a very low level, provisions to minimize touch voltage must be implemented. Approved techniques are the insulation of the exposed down conductor against a 100 kV, 1.2/50 μ s impulse withstand voltage, (3 mm minimum thickness cross-linked polyethylene insulator suggested) or physical restrictions and/or warning notices to minimize the probability of down conductors being touched.

If the decision to allow the use of ladders and handrails as down conductors is not reversed, it is imperative that provisions for minimizing touch voltages be required.

Committee Meeting Action: Accept in Principle in Part

Change 4.9.3.2 to read as follows:

4.9.3.2 Permanent exterior metal handrails and ladders that are subject to direct lightning strikes (e.g., on roofs or between roofs) and are electrically continuous shall be permitted to be used as main conductors where the minimum thickness is 1.63 mm (0.064 in).

Committee Statement: The committee chooses to retain “ladders” in 4.9.3.1.

The committee provides edit to the text.

The change satisfies the submitter’s intent.

Number Eligible to Vote: 30

Ballot Results: Affirmative: 24 Negative: 1 Abstain: 1

Ballot Not Returned: 4 Dyl, D., Heary, W., Rapp, R., Reehl, D.

Explanation of Negative:

GUTHRIE, M.: I cannot agree with any proposal that would essentially remove a requirement for a down conductor and allow an object that may be in an area of high exposure to living beings to be used as the down conductor. A fundamental element of lightning protection is to minimize unnecessary exposure of people to down conductors and the use of a ladder clearly would not meet this criteria. Where exposure to down conductors cannot be eliminated, provisions to minimize touch voltage must be implemented. Acceptable techniques include the insulation of down conductors or the installation of warning notices that these items are part of the lightning protection system and should not be touched when lightning is probable. Without such restrictions, ladders should not be used as a replacement for a down conductor.

It is also recommended that the Committee Statement be changed to reflect that the change clearly does not satisfy the submitters intent as it is exactly opposite of what was proposed.

Explanation of Abstention:

KAISER, B.: See My Explanation of Abstention on 780-1 (Log #5).

780-5 Log #27 **Final Action: Reject**
(4.4.2)

Submitter: Mitchell Guthrie, Blanch, NC

Comment on Proposal No: 780-18

Recommendation: Revert to the existing wording.

Substantiation: There is absolutely no benefit gained from the proposed change. The existing wording says exactly what is intended and is perfectly clear to the user of the document. The definition of bonding makes it clear that a bond is an electrical connection so the proposal appears only to be making a change for the sake of change without any noticeable benefit to the document.

Committee Meeting Action: Reject

Committee Statement: “Bonded” correctly defines the required connection.

Number Eligible to Vote: 30

Ballot Results: Affirmative: 25 Abstain: 1

Ballot Not Returned: 4 Dyl, D., Heary, W., Rapp, R., Reehl, D.

Explanation of Abstention:

KAISER, B.: See My Explanation of Abstention on 780-1 (Log #5).

780-6 Log #26 **Final Action: Accept in Principle**
(4.5.2)

Submitter: Mitchell Guthrie, Blanch, NC

Comment on Proposal No: 780-20

Recommendation: It is recommended that the committee statement be amended to reflect the reason the proposal was changed by the committee and that the revised wording be changed as follows:

4.5.2 Aluminum materials shall not be used within 460 mm (8 in.) of the point where the lightning protection system conductor, etc. comes into contact with earth.

Substantiation: The intent of the committee in accepting the proposal in principle and adding the limitation that it is only applicable to aluminum materials on the exterior of the building was to make it clear that aluminum materials may be used below grade on the interior of a structure even if it is installed on an exterior wall that is less than 8-inches thick. This intent is not properly reflected in the committee statement. This is important because I do not believe it is the intent of the committee that aluminum materials may be used where they come into direct contact with earth even if it is internal to the structure; as is allowed by the committee’s proposed wording. Proposed revised wording is forwarded to indicate that aluminum is not allowed within 460 mm of the point at which the conductor enters the earth, whether this point is internal or external. This will allow aluminum material to be used on an external wall as long as it does not “enter the earth” or is within 8 inches of that point.

Committee Meeting Action: Accept in Principle

Committee Statement: See Committee Action and Statement on 780-7 (Log #30). The committee corrects 8 in. to 18 in.

Number Eligible to Vote: 30

Ballot Results: Affirmative: 25 Abstain: 1

Ballot Not Returned: 4 Dyl, D., Heary, W., Rapp, R., Reehl, D.

Explanation of Abstention:

KAISER, B.: See My Explanation of Abstention on 780-1 (Log #5).

780-7 Log #30 **Final Action: Accept**
(4.5.2)

Submitter: John M. Tobias, US Army CELCMC

Comment on Proposal No: 780-20

Recommendation: Revise 4.5.2 to read:

Aluminium materials shall not be used within 460 mm (18 in.) of the point where the lightning protection system conductor comes into contact with the earth.

Substantiation: Section 4.5.2 as accepted by the committee in the A2007 ROP did not consider the possibility of using aluminum material on the interior of a structure below grade. This revision is more clear and meets the intent of preventing corrosion on aluminum lightning protection components.

Committee Meeting Action: Accept

Number Eligible to Vote: 30

Ballot Results: Affirmative: 25 Abstain: 1

Ballot Not Returned: 4 Dyl, D., Heary, W., Rapp, R., Reehl, D.

Explanation of Abstention:

KAISER, B.: See My Explanation of Abstention on 780-1 (Log #5).

780-8 Log #36 **Final Action: Accept in Principle**
(4.5.2)

Submitter: Melvin K. Sanders, Ankeny, IA

Comment on Proposal No: 780-20

Recommendation: Change the Committee’s “Accept in Principle” text to read as follows:

“4.5.2 Aluminum materials on the exterior of the building shall not be used on the exterior or within the interior where within 460 mm (18 in.) of the point where the lightning protection system conductor comes into contact with earth soil nor in contact with soil.”

Substantiation: If the intent is as Mr. Guthrie states is to make clear to the user that use of aluminum materials are to be prohibited within 18 in. of the contact point to earth, this should be more clearly indicated. This will also clarify to the user that use of aluminum material along interior walls below grade will also be permitted even though they are not 18 in. minimum thickness.

Committee Meeting Action: Accept in Principle

Committee Statement: See Committee Action and Statement on 780-7 (Log #30).

Number Eligible to Vote: 30

Ballot Results: Affirmative: 25 Abstain: 1

Ballot Not Returned: 4 Dyl, D., Heary, W., Rapp, R., Reehl, D.

Explanation of Abstention:

KAISER, B.: See My Explanation of Abstention on 780-1 (Log #5).

780-9 Log #25 **Final Action: Accept in Principle**
(4.6.3.1)

Submitter: Mitchell Guthrie, Blanch, NC

Comment on Proposal No: 780-24

Recommendation: I concur with the submitter’s proposal to include “overturning” and “displacement” and recommend the action taken by the committee be modified to accept the proposal versus accept in principle with the removal of the term “overturning.”

Substantiation: Webster’s New World Dictionary defines displacement as being moved from its customary place. While it is agreed that a literal interpretation of the definition would include overturning, this may not be obvious to all AHJs.

Committee Meeting Action: Accept in Principle

Committee Statement: See Committee Action and Statement on 780-10 (Log #35).

Number Eligible to Vote: 30

Ballot Results: Affirmative: 25 Abstain: 1

Ballot Not Returned: 4 Dyl, D., Heary, W., Rapp, R., Reehl, D.

Explanation of Abstention:

KAISER, B.: See My Explanation of Abstention on 780-1 (Log #5).

780-10 Log #35 **Final Action: Accept**
(4.6.3.1)

Submitter: Melvin K. Sanders, Ankeny, IA

Comment on Proposal No: 780-24

Recommendation: The original proposal to add “displacement” to the present text should have been a straight “Accept” so it would read as follows:

“4.6.3.1 Air terminals shall be secured against overturning or displacement by one of the following...”

Substantiation: “Overturning” is sometimes assumed to be completely turned upside down and displacement alone seems more in line with sizing a battleship. The two words together will be beneficial to the AHJ.

Committee Meeting Action: Accept

Number Eligible to Vote: 30

Ballot Results: Affirmative: 25 Abstain: 1

Ballot Not Returned: 4 Dyl, D., Heary, W., Rapp, R., Reehl, D.

Explanation of Abstention:

KAISER, B.: See My Explanation of Abstention on 780-1 (Log #5).

780-11 Log #4 **Final Action: Accept in Principle**
(4.7)

Submitter: Matthew Caie, ERICO, Inc.

Comment on Proposal No: 780-26

Recommendation: Continue to accept Committee Action and add an additional sentence as follows: “As wind turbines are unique structures, the zones of protection shall include the supporting structure and overall blade rotation perimeter; refer to Annex O.”

Add a new Annex O with title to read as follows: “Annex O WIND TURBINE GENERATOR SYSTEMS”

Annex O text to read as follows: “This annex is not a part of the requirements of this NFPA document but is included for informational purposes only.

Damage to wind turbines due to lightning strokes has been recognized as an increasing problem due to the increasing number and height of installed turbines. Wind turbines present a unique lightning protection problem due to their physical construction of insulating composite materials, such as glass fiber reinforced plastic or other non-conductive materials. The lightning protection system therefore typically has to be fully integrated into the different parts of the wind turbines to ensure that all parts likely to be lightning attachment points are able to withstand the impact of the lightning and that the lightning current may be conducted safely from the attachment points to the ground without unacceptable damage or disturbances to the systems.”

Substantiation: An annex is required to provide the level of protection required for these unique structures. This material is intended to provide some general guidance in the protection of typical wind turbines and similar style structures.

It is my understanding that Annex O was proposed, developed and accepted by the Technical Committee during the ROP, then excluded due to various copyright concerns.

Given the amount of growth today within this industry, the protection of wind turbines requires national guidelines be established for wind turbine protection.

My comment is that this proposed text be included in the current revision and that consideration be provided for the following reasons:

1. The text was written upon request of the committee to be based around existing IEC standards; permission was sort of, and to my knowledge, granted before the work was undertaken.

2. The US represents to IEC, and therefore is able to take from relevant IEC documents and apply locally.

Again the proposal was worked by the NFPA 780 Task Group, accepted during the ROP, and there is need for this material in the industry.

Committee Meeting Action: Accept in Principle

Add new 5.8 to read as follows:

5.8 Wind Turbines. Where a lightning protection system is provided for wind turbines, zones of protection shall include the supporting structure and overall blade rotation perimeter; refer to Annex O.

Annex O Wind Turbine Generator Systems

This annex is not a part of the requirements of this NFPA document but is included for informational purposes only.

O.1 General. Damage to wind turbines due to lightning has been recognized as a growing problem due to the increasing number and height of installed turbines. Wind turbines present a unique lightning protection problem due to their physical construction of insulating composite materials, such as glass fiber reinforced plastic or other non-conductive materials. The lightning protection system typically has to be fully integrated into the different parts of the wind turbines to ensure that all parts likely to be lightning attachment points are able to withstand the impact of the lightning and the lightning current may be conducted safely from the attachment points to the ground without experiencing damage or disturbances to the systems. While physical blade damage is the most expensive and disruptive damage caused by lightning, by far the most common is damage to the control system. Unlike lightning damage to wind turbine blades, damage to control systems comes from both direct and indirect sources.

O.1.1 Protection of Wind Turbine Blades. Modern turbine blades are typically constructed of composite materials such as carbon or glass reinforced plastic. Some parts and discrete components such as mounting flanges, balancing weights, hinges, bearings, wires, electrical wiring, springs, etc. are made of metal. Lightning strikes blades that have metallic and non-metallic components. The technical challenge in the design of lightning protection of wind turbine blades is to conduct the lightning current safely from the strike attachment point to the hub, in such a way that the formation of a lightning arc inside the blade is avoided. This can be achieved by diverting the lightning current from the strike attachment point along the surface to the blade root, using metallic conductors, either fixed to the blade surface or inside the blade.

Typically for blades up to 20 m (60 ft.) long, receptors at the tip of the blade are adequate. However, it may be necessary for longer blades to have more than one receptor to obtain the desired interception efficiency. Protection of the blades is provided by the blade manufacturer and is typically an integral part of the blade.

Any wiring for sensors placed on or inside blades should be protected via bonding to the down conduction system. Wiring should either be shielded cables or placed in metal tubes. The cable shield or metal tube should be placed as close as possible to the down conductor and bonded to it.

O.1.2 Protection of Wind Turbine Structures. With the blade being provided with integral protection, the wind turbine should be protected in accordance with the main body of this standard. The placement of air terminals on parts of the wind turbine structure other than the blades is to be determined with reference to Chapter 4 of this standard. Specifically, when determining protection zones, the blades are assumed to be stationary within the “worst case” scenario position (where the blades are oriented so they provide the smallest zone of protection to the structure). The materials used for lightning protection of wind turbine blades should be able to withstand the electric, thermal and electro-dynamic stresses imposed by the lightning current. Minimum dimensions for materials used for air termination and down conduction are provided in Chapter 4 of this standard.

O.1.3 Protection of Bearings and Gearbox. Arcing between bearing raceways and rolling elements can dissipate sufficient energy to cause severe pitting. Such damage may not be identified as being caused by lightning and can result in a greatly reduced lifetime of the bearing. It is possible that large heavily loaded bearings and stationary bearings may be able to conduct the lightning current without significant damage. Therefore lightning protection of the slow moving pitch bearings and yaw bearings may not be needed.

For additional protection or in the case of lighter weight bearings, it is recommended that an alternative supplemental current path be provided across the bearings with a flexible conductor, a sliding contact or similar arrangement.

O.1.4 Protection of Electrical and Control System. Lightning currents can induce transients into circuits through various coupling mechanisms such as conduction, capacitive and magnetic coupling. The following are general recommendations to limit these coupling mechanisms:

1. Providing preferential, low impedance paths for the lightning current can minimize conductive coupling. Proper separation distances and good bonding techniques as defined in Section 4 of this standard can prevent flashovers.
2. Capacitive coupling between conductors designed to carry the lightning current and a component (cable and/or electrical equipment) can be reduced by:
 - shielding (a complete metal enclosure, braided wire sheath or wire mesh screen)
 - increasing the distance between lightning conductors and such components (e.g., move the wires close to a ground plane, use grounded metallic conduit, wireways or raceways)
3. Magnetic coupling to electrical or control cabling and equipment can be reduced by:
 - metal enclosures (raceways, pipes, shields, metal box)
 - avoid forming large-loop areas with electrical or control cabling
 - keep conductors close to metal components such as gearboxes and generators
 - twisted pairing of cables can reduce magnetic coupling

Bonding within the wind turbine is required to reduce voltage differences between parts of the wind turbine. This bonding provides protection against touch and step voltages during a lightning strike.

Electrical power equipment such as motors, generators, transformers, and switchgear is designed to withstand high-voltage surges. Insulation of electrical power equipment normally withstands transient voltages in the kilovolt range. It is recommended that a surge protection device (SPD) rated above the operating line voltage and possible temporary over voltages be used. Otherwise, the SPD may conduct current during

normal line variations and have greatly reduced service life. Further guidelines for the application of SPDs are found in Section 4.18 of this document and ANSI/IEEE 62.41.

Signal circuits can only withstand transient voltages of some tens of volts and such circuits are susceptible to transient over voltages particularly in such an exposed environment of a wind turbine. Depending on the nature of the equipment being protected, the correct array of SPDs should be selected and installed as close as practical to the equipment to be protected.

O.2 Blade-to-Hub Connection. At the base of the blade, the down conductor system is usually either terminated to the blade-mounting flange or to the hub.

Blades could be either pitch regulated or equipped with a tip brake. In such cases, the hydraulic control or pitch bearing is required to be protected using either a sliding contact or a flexible bonding cable with enough slack to allow for motion. This bonding is required to provide a preferred path for the lightning energy from the blade conductor to the hub.

Care must be taken to reduce the slack in such bonding straps, since the inductive voltage drop across the slack may become very high, thus resulting in inefficient protection.

O.3 Grounding. Each wind turbine must be equipped with its own grounding electrode system, and interconnected to a site grounding system, if present. The lightning protection system grounding should be designed in accordance with the minimum requirements of this standard. However, consideration should be given to typical factors in a power generation facility such as sizing conductors for fault currents, and touch and step potential requirements. These factors are outside the scope of this annex. The grounding of a wind turbine would then comprise a ground ring electrode external to the structure (defined by the radius of the turbine foundation) in contact with the soil, bonded to the foundation reinforcing bars. Additional vertical and horizontal grounding electrodes may be used in combination with the ring electrode. The ring electrode should be buried to a depth of at least 460 mm (18 in.). Horizontal electrodes may be used to connect the grounding system of one wind turbine to the site grounding system. The lightning protection grounding electrode must always be bonded to the power grounding system.

Add the following to the end of Annex N.1.2.1 to read as follows:

IEC 61400-24, *Wind Turbine Generator Systems – Part 24: Lightning Protection*, 2002.

Add the following to the end of Annex N.1.2.4 to read as follows:

Cotton, I.; Jenkins, N. "Lightning Protection of Wind Turbines, Lightning Protection 98, Buildings, Structures and Electronic Equipment, International Conference and Exhibition, Paper 6.1," Solihull, West Midlands, UK, 6-7 May 1998.

D'Alessandro, F.; Havelka, M. "Electrical Grounding of Wind Turbines," EEA Annual Conference, AUCKLAND, New Zealand, 17-18 June 2005.

Committee Statement: The committee accepts the submitter's recommendation and provides edit to the text. The change satisfies the submitter's intent.

The committee chooses to relocate the text to Chapter 5 as a wind turbine is considered to be a miscellaneous structure.

Number Eligible to Vote: 30

Ballot Results: Affirmative: 25 Abstain: 1

Ballot Not Returned: 4 Dyl, D., Heary, W., Rapp, R., Reehl, D.

Explanation of Abstention:

KAISER, B.: See My Explanation of Abstention on 780-1 (Log #5).

Comment on Affirmative:

GUTHRIE, M.: I concur with the committee action on the proposal, but suggest that the following editorial revision to proposed 5.8: "5.8 Wind Turbines. Where a lightning protection system is provided for wind turbines, zones of protection shall include the supporting structure and overall blade rotation perimeter; refer to (see Annex O)."

780-12 Log #23 **Final Action: Accept**
(4.7.3.4)

Submitter: Mitchell Guthrie, Blanch, NC

Comment on Proposal No: 780-34

Recommendation: Change upper case "D" in Figure 4.7.3.3 to "2R" in the formula.

Change "D" to "R" in the legend where "R = rolling sphere radius [46 m (150 ft)]"

Substantiation: The committee action results in both a lower and upper case "d" in the equation. There was some discussion during the ROP meeting that there was confusion by some casual users of the formula as to the source of the value of 300 used in the formula. The substitution of the variable "D" resolves this confusion. However, the use of the variable "2R" in place of "D" (where R is the striking distance) would be even clearer as to the source and it would eliminate the need to use both an upper case and lower case "d" in the formula.

Committee Meeting Action: Accept

Committee Statement: The committee notes the formula and legend are in 4.7.3.4.

Number Eligible to Vote: 30

Ballot Results: Affirmative: 25 Abstain: 1

Ballot Not Returned: 4 Dyl, D., Heary, W., Rapp, R., Reehl, D.

Explanation of Abstention:

KAISER, B.: See My Explanation of Abstention on 780-1 (Log #5).

780-13 Log #24 **Final Action: Accept in Principle**
(4.7.2.2)

Submitter: Mitchell Guthrie, Blanch, NC

Comment on Proposal No: 780-28

Recommendation: The committee action should be to Accept in Principle with the following revision:

4.7.2.2 The zone of protection shall form is defined as a cone whose apex is located at the highest point of the strike termination device, with walls surface forming by a 45-degree or 63-degree angle from the vertical.

Substantiation: The proposed revision is incorrect. First, the zone of protection is defined as a volume, not a surface. Second, a "surface" is not typically considered to have an apex as an "apex" is defined by Webster's Dictionary as: (1) the highest point or (2) the usually pointed end of an object.

Committee Meeting Action: Accept in Principle

Change 4.7.2.2 to read as follows:

4.7.2.2 The zone of protection is a cone with the apex located at the highest point of the strike termination device, with its surface formed by a 45-degree or 63-degree angle from the vertical.

Committee Statement: The committee accepts the submitter's recommendation and provides edit to the text. The change satisfies the submitter's intent.

Number Eligible to Vote: 30

Ballot Results: Affirmative: 25 Abstain: 1

Ballot Not Returned: 4 Dyl, D., Heary, W., Rapp, R., Reehl, D.

Explanation of Abstention:

KAISER, B.: See My Explanation of Abstention on 780-1 (Log #5).

780-14 Log #34 **Final Action: Accept in Principle**
(4.7.2.2)

Submitter: Melvin K. Sanders, Ankeny, IA

Comment on Proposal No: 780-28

Recommendation: The present text of NFPA 780-2004 should be retained and modified as follows:

4.7.2.2 The zone of protection shall form a cone whose apex is located at the highest point of the strike termination device, with walls its outer surface forming a 45-degree or 63-degree angle from the vertical.

Substantiation: "Zone of Protection" is already defined in 3.3.35 as a surface, and the Committee's "Accept in Principle" of "line of protection" does not follow that meaning. Mr. Guthrie's suggestion to provide a new definition of "Zone of Protection" is not in agreement with the present definition, and that issue should be addressed there if additional clarity is needed. A (virtual reality) cone provides a surface volume concept for evaluation by user's as to the included areas more likely to be so protected. The Accept in Principle use of the phrase "a line" indicates a one or two dimension flat surface and does not convey the meaning inherent in the original text of a three dimensional space.

Committee Meeting Action: Accept in Principle

Committee Statement: See Committee Action and Statement on 780-13 (Log #24).

Number Eligible to Vote: 30

Ballot Results: Affirmative: 25 Abstain: 1

Ballot Not Returned: 4 Dyl, D., Heary, W., Rapp, R., Reehl, D.

Explanation of Abstention:

KAISER, B.: See My Explanation of Abstention on 780-1 (Log #5).

780-15 Log #8 **Final Action: Accept in Principle**
(4.8.2)

Submitter: John M. Tobias, US Department of the Army

Comment on Proposal No: 780-35

Recommendation: See the following figures:

Existing:

4.8.2 Location of Devices. As shown in Figure 4.8.2, strike termination devices shall be placed at or within 0.6 m (2 ft) of ridge ends on pitched roofs or at edges and outside corners of flat or gently sloping roofs.

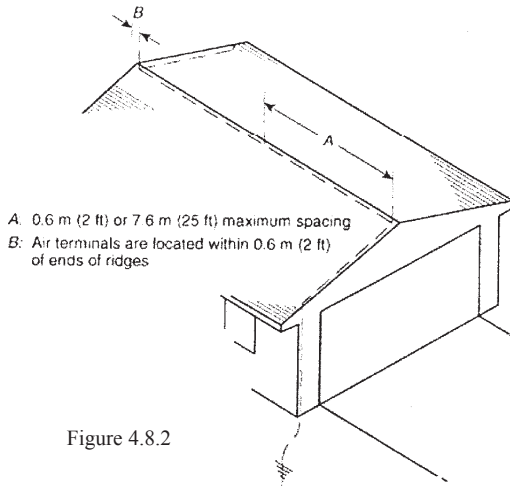

A: 0.6 m (2 ft) or 7.6 m (25 ft) maximum spacing
 B: Air terminals are located within 0.6 m (2 ft) of ends of ridges

Figure 4.8.2

Change to:

4.8.2 Location of Devices. For Class I installations, where the roof height does not exceed 75 ft., strike termination devices shall be placed at or within 0.6 m (2 ft) of ridge ends on pitched roofs or at edges and outside corners of flat or gently sloping roofs, as shown in Figure 4.8.2a. For Class II installations, this spacing between the strike termination device and the roof edge shall not exceed the height of the strike termination device above the roof edge level, as shown in Figure 4.8.2b.

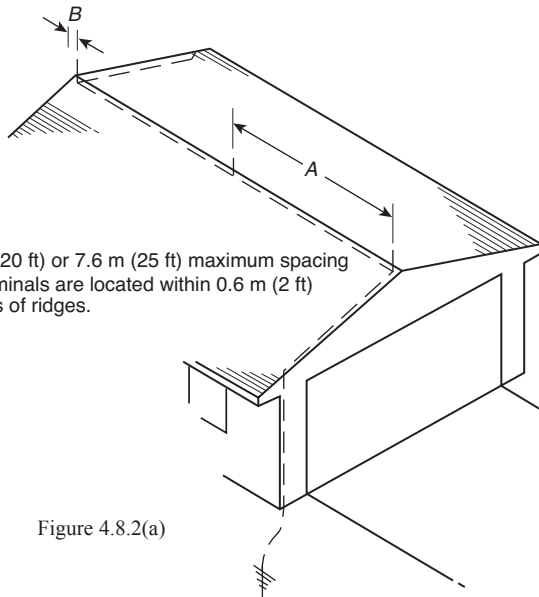

A: 6.0 m (20 ft) or 7.6 m (25 ft) maximum spacing
 B: Air terminals are located within 0.6 m (2 ft) of ends of ridges.

Figure 4.8.2(a)

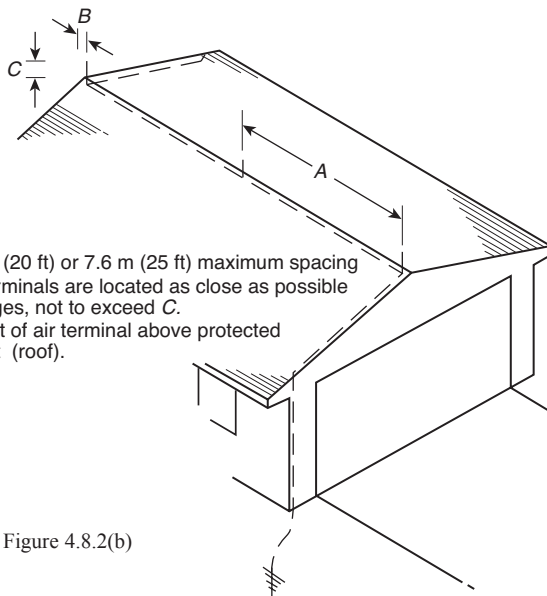

A: 6.0 m (20 ft) or 7.6 m (25 ft) maximum spacing
 B: Air terminals are located as close as possible to ridges, not to exceed C.
 C: Height of air terminal above protected object (roof).

Figure 4.8.2(b)

Substantiation: Rejection of the original proposal 780-35 leaves an established gap in lightning protection for taller structures. Yet, the proposal as originally written was too restrictive for Class I structures. (See voting explanations in ROP A2007.) This comment addresses the need to place air terminals closer to a roof edge for class II structures in order to minimize the possibility of bypass and attachment to a roof edge. In addition, this comment brings NFPA 780 air terminal placement requirements into closer coordination with IEC lightning protection standards.

Information presented (by Dr. D’Alessandro) at May 2005 Pre-ROP meeting indicated that there are a number of ‘bypasses’ where corners of buildings are struck despite the presence of a strike termination. Using other sources (for example derived from Tobias, J. M., ed., *The Basis of Conventional Lightning Protection Technology*, Federal Interagency Lightning Protection Group, Available on www.stinet.dtic.mil, Report No. ADA396784, p. 21, June 2001) the effective protection angle for short distances is agreed to be 45 degrees. By requiring that the air terminal is placed at a distance not to exceed its height above the protected object, the 45 degree protection angle is enforced.

Further consideration given to this issue in the 780 2007 ROP noted that the distance of air terminals to roof edge was dependent upon height of the structure, as Mr. Caie notes, referring to well established IEC standards. This comment addresses that point in the context of NFPA 780 techniques and terminology and brings 780 into closer coordination with IEC lightning protection standards.

Additional Substantiation (From A2007 ROP voting explanations)

Explanation of Negative:

CAIE, M.: This proposal was rejected on the basis that the placement of air terminals at a distance of up to 2 ft from a likely strike point on a structure “has not caused any problems”. However:

- No substantiation was provided to back this claim, e.g., the types and heights of buildings, the lightning activity in the regions supposedly identified, quantitative results of field studies, etc.
- If a proper field survey is carried out and examples are found where the 2 ft distance is, as suspected, too large in high lightning areas and on taller structures, the whole issue would need to be re-opened.

A quantitative study was carried out recently [1] and presented in three different international fora. It showed that a fixed 2 ft rule is not appropriate and for short rods, like the ones typically installed in the USA (10” or 12” length), the 2 ft rule is much too loose for protecting vulnerable points on structures. The study also showed that the maximum distance is dependent on the height of air terminal that is installed.

Furthermore, if one considers what is recommended in other international standards such as the IEC, 10” and 12” rods would need to be installed much closer than the allowable 2 ft distance. For example, IEC62305-3 shows that the “protection angle method” can be used in this situation for structures up to 200 ft in height. Appendix E, Fig. E.12, clearly shows that if a rod is positioned near an edge or corner of a building, the height of the rod and the building are applied in the normative Table 2 of the standard.

Taking a 10 in. rod as an example, the maximum distance from the edge or corner of the structure that is allowable for structure heights in the range 16 – 200 ft is 2.2 – 0.35 ft. This range is based on Level III protection, which is essentially equivalent to the single protection level used in NFPA 780 (150 ft rolling ball etc.). From [1], the recommended maximum distance for 10 in. rods on a 165 ft building is 0.27 ft, in good agreement with the value determined from the IEC standard.

So, the question remains – what is the basis or justification for the 2 ft rule in NFPA 780 and the reason to reject a rigorous quantitative analysis that agrees with the IEC standard ?

References

- [1] D’Alessandro, F., 2004, “Improved placement of protective lightning rods on structures”, *Proc. Internat. Conf. Grounding & Earthing (Ground’2004)*, Belo Horizonte, Brazil, pp. 138-143.
- [2] International Electrotechnical Committee, “IEC 62305-3 Ed. 1.0: Protection against lightning – Part 3: Physical damage to structures and life hazard”, CEI, Geneva, Switzerland, 2006.

TOBIAS, J.: Comments from Caie are correct and need consideration. Sufficient substantiation exists for the original proposal.

Comment on Affirmative:

GUTHRIE, M.: I agree with the concept of the original rejected proposal but also agree with the committee’s decision to reject the proposal at this time. A preference would be to accept the original proposal in principle with some revision to the text to reflect the principles cited by Mr. Caie in his negative vote. However, I do not believe we are at the point where we can reach agreement on the specific text at this point. Mr. Caie references the D’Alessandro Ground 2004 paper as a primary justification for the need for this change and indicates that it shows the 2-foot rule is much too loose for protecting vulnerable points on structures. He also cites IEC 62305-3 as justification for this change. In response, it should be identified that NFPA 780 is one of the more stringent of the standards in use in the world as it relates to spacing of air terminals from the corners of a protected structure. It is also unclear whether any of the bypasses discussed in the D’Alessandro paper were associated with installations where the air terminal spacing met the existing requirements of NFPA 780. It is also interesting that the example given by Mr. Caie considers a structure of 165 feet height. It should be noted that the protective angle specified in IEC 62305-3 changes as a function of height of the structure/air terminal. IEC 62305-3, 5.2.2 identifies that a 45-degree angle

would be excessive for structures of less than 30 meters in height. For a 10-meter tall structure, the IEC 62305-3 protective angle exceeds 60 degrees. In these cases, the 2-foot spacing is exceedingly conservative. In conclusion, I agree that the 2-foot spacing should be assessed for tall structures such as the 165-foot tall structure discussed by Mr. Caie. However, I believe it would be excessive to require that the 45-degree angle be applicable across the board as proposed in ROP 780-35.

Committee Meeting Action: Accept in Principle

Change 4.8.2 to read as follows:

4.8.2* Location of Devices. As shown in Figure 4.8.2, the distance between strike termination devices and ridge ends on pitched roofs or edges and outside corners of flat or gently sloping roofs shall not exceed 0.6 m (2 ft).

Add annex A.4.8.2 to read as follows:

A.4.8.2 Strike termination devices should be placed as close as practicable to roof edges and outside corners.

Committee Statement: The committee changed the text of 4.8.2 to emphasize that strike termination devices should be installed close to roof edges. Annex material was added to encourage minimizing air terminal to edge distance.

The change satisfies the submitter's intent.

Number Eligible to Vote: 30

Ballot Results: Affirmative: 25 Abstain: 1

Ballot Not Returned: 4 Dyl, D., Heary, W., Rapp, R., Reehl, D.

Explanation of Abstention:

KAISER, B.: See My Explanation of Abstention on 780-1 (Log #5).

780-16 Log #40 Final Action: Reject (4.8.2)

Submitter: Mark P. Morgan, East Coast Lightning Equipment, Inc.

Comment on Proposal No: 780-35

Recommendation: The Committee's rejection of this proposal is correct.

Substantiation: I agree with the comment on affirmative by M. Guthrie as it relates to M. Caie's Explanation of Negative vote on the rejection of this proposal. The information presented by F. D'Alessandro regarding by-passes of air terminals does not constitute a "rigorous quantitative analysis" as relates to NFPA 780 requirements, because none of the by-pass evidence presented occurred in systems installed in accordance with NFPA 780.

Committee Meeting Action: Reject

Committee Statement: The submitter did not provide a recommendation for consideration in accordance with the Regulations Governing Committee Projects, Section 4-3.3(c).

Number Eligible to Vote: 30

Ballot Results: Affirmative: 25 Abstain: 1

Ballot Not Returned: 4 Dyl, D., Heary, W., Rapp, R., Reehl, D.

Explanation of Abstention:

KAISER, B.: See My Explanation of Abstention on 780-1 (Log #5).

780-17 Log #2 Final Action: Reject (4.8.2.3)

Submitter: Harold VanSickle, III, Lightning Protection Institute

Comment on Proposal No: 780-36

Recommendation: Delete 4.8.2.3 Pitched Roof Area entirely including all of paragraph (A) and (B).

Substantiation: The original submitter has outlined a valid problem with the installation of system components at the eave line for ridged roof structures. Following the requirements of NFPA 780 creates a hazard to people below the building perimeter, as well as a situation where proper compliance leads to system components being ripped out of the construction breaking the moisture seal of the structure's exterior in cold climates with snow and ice accumulation. There are substantial enough negative consequences associated with compliance to these paragraphs that owners are forced to either ignore or risk their property and the people below.

The vote to reject by the NFPA 780 Committee cites the original submitter's lack of providing adequate substantiation. He has indicated the problem and the need to delete the paragraphs. I would also point out that later in this same meeting, the NFPA 780 Committee accepted Proposal No. 780-100 that speaks to a very similar issue. When the Committee justifies not protecting the top vertical edges of tall buildings that "are subject to direct strikes", then the Committee has provided its own justification for not protecting eave lines on tall, ridged roof structures. Protection of eave lines "will not normally be justified" because it leads to negative consequences for performance of the construction for any reasonable period of time.

Committee Meeting Action: Reject

Committee Statement: Removal of these paragraphs creates inconsistencies in other areas of the NFPA 780 document.

The submitter has not provided adequate substantiation.

The committee does not agree with the submitter's substantiation.

Number Eligible to Vote: 30

Ballot Results: Affirmative: 22 Negative: 3 Abstain: 1

Ballot Not Returned: 4 Dyl, D., Heary, W., Rapp, R., Reehl, D.

Explanation of Negative:

FRANKLIN, D.: I must disagree with the committee statement behind

rejecting this proposal. The opposite case is actually true. Inconsistencies exist if 4.8.2.3 is not dropped. There is nothing magical and no logical basis that demands the rolling sphere be applied to eave lines of 50' or more. For instance, this is totally inconsistent with the application of the 150' radius sphere to the sides of tall structures.

Would using the rolling sphere at elevations about 150' above grade dictate protecting the flat side walls of a building over 150' as if they are flat roofs? No, and for the same reason that for decades there is a proven safe performance record of protecting the ridge only of 1/4 pitch roofs. Real world risks do not, for practical purposes, exist at either of these areas.

The arbitrary adoption of an unnecessary, much more stringent rule that actually creates more problems as cited in the prior, original proposal is not justifiable.

It would only be at the 150' eave elevation that applying the rolling ball to the slope roof area makes sense, or would be appropriate.

PORTFLEET, T.: My disposition is to accept not reject.

Rational: Mandating air terminal placements at eave lines of pitched roof structures does create inevitable hazards to both personal and building structures. Field histories testifying to the dysfunction of such air terminal placement especially in cold climates abounds.

VANSICKLE, III, H.: I continue to disagree with this wording in the 780 document for the reasons stated in my proposal. I do not agree with the vote of the majority in attendance at the meeting to reject this proposal, and I do not agree with the points of the Committee Statement for rejection of the same.

Explanation of Abstention:

KAISER, B.: See My Explanation of Abstention on 780-1 (Log #5).

780-18 Log #7 Final Action: Accept in Principle (4.8.7)

Submitter: John M. Tobias, US Department of the Army

Comment on Proposal No: 780-41

Recommendation: Add new text to read as follows:

4.8.7.1 Wind Turbines. Zones of Protection for Wind Turbines will consider their blade diameter and have no part outside of a zone of protection afforded by the blades.

See Annex for additional information.

NFPA 780 new ANNEX MATERIAL FOR 4.8.7.1

WIND TURBINE GENERATOR SYSTEMS –

INTRODUCTION

Damage to wind turbines due to lightning strokes has been recognized as an increasing problem. The increasing number and height of installed turbines have resulted in an incidence of lightning damage greater than anticipated with repair costs beyond acceptable levels. Wind turbines pose a unique lightning protection problem due to their physical size and nature. There is extensive use of insulating composite materials, such as glass fibre reinforced plastic, as load carrying parts. The lightning protection system has to be fully integrated into the different parts of the wind turbines to ensure that all parts likely to be lightning attachment points are able to withstand the impact of the lightning and that the lightning current may be conducted safely from the attachment points to the ground without unacceptable damage or disturbances to the systems. The specific problems to modern wind turbines are a result of the following:

- wind turbines are frequently placed at locations very exposed to lightning strokes;
- the most exposed wind turbine components such as blades are often made of composite materials incapable of sustaining direct lightning stroke or of conducting lightning current;
- the blades are rotating;
- the lightning current has to be conducted through the wind turbine structure to the ground, whereby significant parts of the lightning current will pass through or near to practically all wind turbine components

Lightning striking unprotected blades manufactured from composite material invariably causes severe damage since these materials are poor conductors of lightning current. While physical blade damage has been shown to be the most expensive type of damage studies have shown that by far the most common was damage to the control system. Unlike lightning damage to wind turbine blades, damage to control systems comes from a number of direct and indirect sources.

LIGHTNING PROTECTION OF WIND TURBINES

WIND TURBINE BLADES

Modern wind turbine blades are large hollow structures manufactured of composite materials, such as glass reinforced plastic (GRP), wood, wood laminate and carbon reinforced plastic (CRP). Some parts and discrete components such as mounting flanges, balancing weights, hinges, bearings, wires, electrical wiring, springs and fixtures are made of metal. Lightning does in fact strike blades without any metallic components, and whenever a lightning arc is formed inside the blade damage is severe. There are several types of blades depending on the control and braking mechanism employed. Four main types are shown in Figure 1.

Type A blades, lightning attachment points are often found on the steel flap hinges, and severe damage is often seen since the cross-section of the steel wires used for operating the flap is usually insufficient for conducting the lightning current.

Type B blades, lightning attachment points are predominantly seen within a

few feet from the outermost tip, or on the sides of the tip at the position of the outermost end of the tip shaft. From the attachment point, a lightning arc is formed inside the tip section to the outermost end of the tip shaft, and from the other end of the shaft an arc is formed inside the main blade down to the steel-mounting flange at the blade root. Such internal arcs invariably cause catastrophic destruction to the blade.

Type C blades, lightning attachment points are predominantly found within a few tens of cm from the outermost tip of the blade, or on the sides of the tip at the position of the outermost end of the tip shaft. With type C as with type B, a lightning arc formed inside the tip section between the attachment point and the outermost end of the shaft causes severe damage.

Type D is a blade constructed entirely from non-conducting materials. As with the other types of blades, lightning attachment points are mostly found close to the tip. Compared to the other types of blades, attachment points can also be found randomly distributed at other positions along the length of the blade.

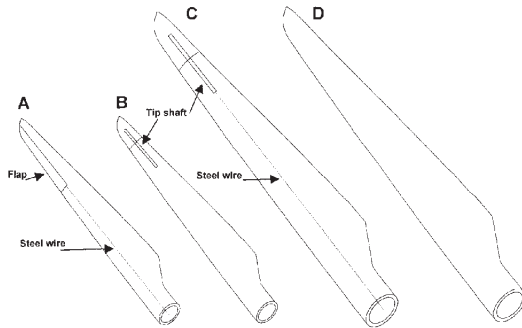

Figure 1 Types of wind turbine blades.

The problem of lightning protection of wind turbine blades is to conduct the lightning current safely from the attachment point to the hub, in such a way that the formation of a lightning arc inside the blade is avoided. This can be achieved by diverting the lightning current from the attachment point along the surface to the blade root, using metallic conductors either fixed to the blade surface or inside the blade. Another method is to add conducting material to the blade surface material itself, thus making the blade sufficiently conducting to carry the lightning current safely to the blade root. Variations of both these methods are used with wind turbine blades (see Figure 2).

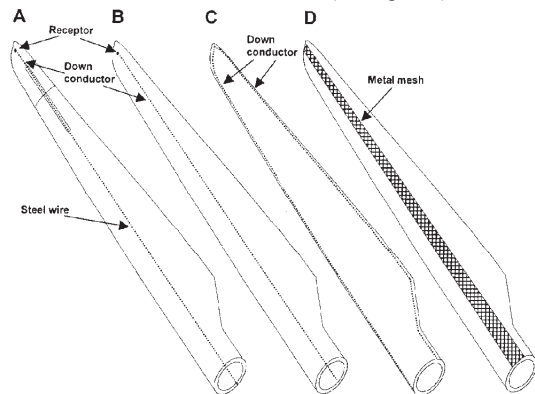

Figure 2 Lightning protection for large modern wind turbine blades.

For blades up to 20 m long, it appears that receptors at the tip of the blade are adequate. It may be necessary for longer blades to have more than one receptor to obtain the desired interception efficiency.

WIND TURBINE STRUCTURE

The protection of the blades is provided by the blade manufacturer and is an integral part of the blade as shown in figure 2. With the blade being provided with integral protection, the wind turbine shall be protected in accordance with the main body of this standard. The placement of air terminals on parts of the wind turbine structure other than the blades shall be determined with reference to Chapter 4. Specifically when determining protection zones, the blades shall be assumed to be stationary within the “worst case” scenario position. The materials used for lightning protection of wind turbine blades shall be able to withstand the electric, thermal and electrodynamic stresses imposed by the lightning current. Minimum dimensions for materials used for air termination and down conduction are provided in Chapter 4 of this standard.

BLADE TO HUB CONNECTION

At the root of the blade, the down conduction system is usually either terminated to the blade-mounting flange or to the hub.

If the blade is pitch regulated (type D), the lightning current is either allowed to pass uncontrolled through the pitch bearing or some kind of bonding across

the bearing is provided such as a sliding contact or a flexible bonding cable with enough slack to allow for the pitch motion. The flexible bonding across the bearing can be combined with the innermost part of the down conductor from the blade.

In blades with tip brake (type C), the hydraulic system, which actuates the control wire, must be protected. Standard hydraulic cylinders that are normally used can be damaged by flashovers from the rod to the cylinder housing. Usually, the hydraulic cylinder is protected by diverting the lightning via a flexible bonding strap with sufficient slack to allow for the motion.

Care must be taken to reduce the slack in such bonding straps, since the inductive voltage drop across the slack may become very high, thus resulting in inefficient protection of the cylinder.

WIRING INSIDE BLADES

Wiring for sensors placed on or inside blades must be protected via bonding to the down conduction system. Wiring should either be shielded cables or placed in metal tubes. The shielded cable or metal tube should be placed as close as possible to the down conductor and bonded to it.

PROTECTION OF BEARINGS AND GEARBOX

Arcing between bearing raceways and rolling elements can dissipate energy enough to cause severe pitting. Such cases of delayed damage are probably never identified as being caused by lightning, however can result in a greatly reduced lifetime of the bearing. It is possible that large heavily loaded bearings and stationary bearings may be able to conduct the lightning current without significant damage. Therefore lightning protection of the slow moving pitch bearings and yaw bearings may not be needed. It is recommended that an alternative current path be provided across bearings at risk with a flexible conductor, a sliding contact or similar arrangement.

PROTECTION OF ELECTRICAL AND CONTROL SYSTEM

Lightning currents can induce transients into circuits through various coupling mechanisms such as conduction, capacitive and magnetic coupling. The following are general recommendations to limit these coupling mechanisms:

1. Providing preferential, low impedance paths for the lightning current can minimize conductive coupling. Proper insulation levels and good bonding techniques can prevent flashovers.

2. Capacitive coupling between one component and another can be reduced by:
 - shielding (a complete metal enclosure, braided wire sheath or wire mesh screen);
 - increasing the distance between the interacting components (for example move the wires close to a ground plane, use grounded metallic conduit, wire ways or race trays), and
 - reducing the exposed surface.

3. Magnetic coupling can be reduced by:
 - high-frequency magnetic fields can be reduced significantly with a metal enclosure (race ways, pipes, shields, metal box). The magnetic disturbance is deflected and dissipated as eddy currents in a metal cover;
 - avoid forming large-loop areas that are susceptible to flux linkage – keep conductors close to metal components such as gearboxes and generators;
 - twisted cables can reduce magnetic coupling because the area enclosed is very small and the signal induced in the wire pairs should cancel at differential inputs.

Bonding within a wind turbine is required to establish equipotential bonds between parts of the wind turbine. These equipotential bonds provide protection against touch and step voltages during a lightning stroke. Some considerations for the bonding and shielding needed in a wind turbine are discussed below. Bonding within a wind turbine should therefore use multiple conductors that are:

- capable of carrying the predicted fraction of lightning current to pass through the path in question;
- as short and straight as possible.

Wiring can also be protected by routing wires in conduits/raceways or by using shielded cable. To prevent voltages being induced into the electrical wiring it is obvious that the reduction of the peak change of magnetic field passing through a loop and the reduction of loop area will result in lower induced voltages. This can be achieved in a number of ways:

- a) Increased separation between the current-carrying conductor and the electrical circuit. This method of reducing induced voltages would work but is not normally possible within the confines of a wind turbine.
- b) Using twisted pair cable will reduce the induced voltage level. Twisted pair systems will reduce differential mode voltages but common mode voltages may still exist;
- c) Use of shielding by using shielded cabling or routing the wiring inside steel pipes or metal conduits is recommended to effectively shield cables from magnetic fields. Protection is only possible when both ends of the shield/pipe/conduit are solidly connected to earth.

In addition to the methods listed above, installing cabling close to the metal structure and avoiding loops of cabling will reduce the magnetic coupling area. These methods will effectively reduce loop areas and shield the wires inside from the changing magnetic fields.

Electrical power equipment such as motors, generators, transformers, and switchgear is designed to withstand high-voltage surges. Insulation of electrical power equipment normally withstands transient voltages in the kilovolt range. In the light of this, it is recommended that a surge arrester or SPD rated above the operating line voltage and possible temporary overvoltages (TOV) be used. Otherwise, the surge arrester or SPD may conduct current during normal line

variations and have greatly reduced service life. Further guidelines for sizing SPDs and surge arrestors are found in (state relevant IEEE, NEC standard here).

In contrast to electrical power equipment, signal circuits can only withstand transient voltages of some tens of volts. Such circuits are susceptible to transient overvoltages especially in the exposed environment of a wind turbine. Depending on the nature of the circuit or equipment being protected, the correct array of SPDs should be selected and installed as close as practical to the equipment to be protected. Newer turbines utilize fibre optics to transfer signals to avoid noise and other circuit disturbances. Fibre optics is quite suitable to protect the signal network against lightning damage when properly utilized. Specifically, fibre optic cables without metallic wires should be used.

GROUNDING

Each wind turbine must be equipped with its own combined ground termination system, even if it is interconnected to a larger wind farm grounding system. The lightning protection system grounding should be designed in accordance with the minimum requirements of this standard, however consideration should be given to typical factors in a power generation facility such a sizing conductors for fault currents and touch and step potential requirements. These factors are outside the scope of this standard. The grounding of a wind turbine shall comprise a ground ring electrode external to the structure (defined by the radius of the turbine foundation) in contact with the soil, bonded to the foundation reinforced concrete. Additional vertical and horizontal ground electrodes may be used in combination with the ring electrode. The ring electrode should be buried to a depth of at least 18 inches. Horizontal electrodes may be used to connect the grounding system of one wind turbine to the next when it is within a wind farm. A typical grounding layout is provided within figure 3. The measurement of grounding system resistance should be carried out for each individual wind turbine earthing system before it is connecting to any other cable type. The lightning protection ground termination system must always be bonded to the power system earth through equipotential bonding.

o Step voltage risks should be minimized by locating controllers or tower entries within the ground electrode ring or ufer grounds or copper mesh beneath the common standing areas for an operator

REFERENCES

IEC 61400-24: Wind Turbine Generator Systems – Part 24: Lightning Protection
 COTTON, I.; JENKINS, N. Lightning Protection of Wind Turbines, Lightning Protection 98, Buildings, Structures and Electronic Equipment, International Conference and Exhibition, Paper 6,1, Solihull, West Midlands, UK, 6-7 May 1998
 D’Alessandro, F.; Havelka, M. Electrical Grounding of Wind Turbines, EEA Annual Conference, AUCKLAND, New Zealand, 17-18 June 2005
 McNiff, B.; McCoy, T.; Rhoads, H.; Lisman, T.; Smith, B. Lightning Activities in the DOE-EPRI Turbine Verification Program, American Wind Energy Associations Wind Power 2000, Palm Springs, California, USA, 6April 30 – May 5 2000

Substantiation: The proposal as written inadequately addresses this class of structure. The class of structures designated as wind turbines, falling generally under structures with rounded roofs due to the similarity of the arc of the rotating blades, need special zone of protection consideration due to the nature of the moveable assemblies and need to be addressed in this section. In order to adequately address the zone of protection issues (and the consequent issues of strike termination) additional (non-normative) annex material is required for explanatory purposes.

Committee Meeting Action: Accept in Principle

Committee Statement: See Committee Action and Statement on 780-11 (Log #4).

Number Eligible to Vote: 30

Ballot Results: Affirmative: 25 Abstain: 1

Ballot Not Returned: 4 Dyl, D., Heary, W., Rapp, R., Reehl, D.

Explanation of Abstention:

KAISER, B.: See My Explanation of Abstention on 780-1 (Log #5).

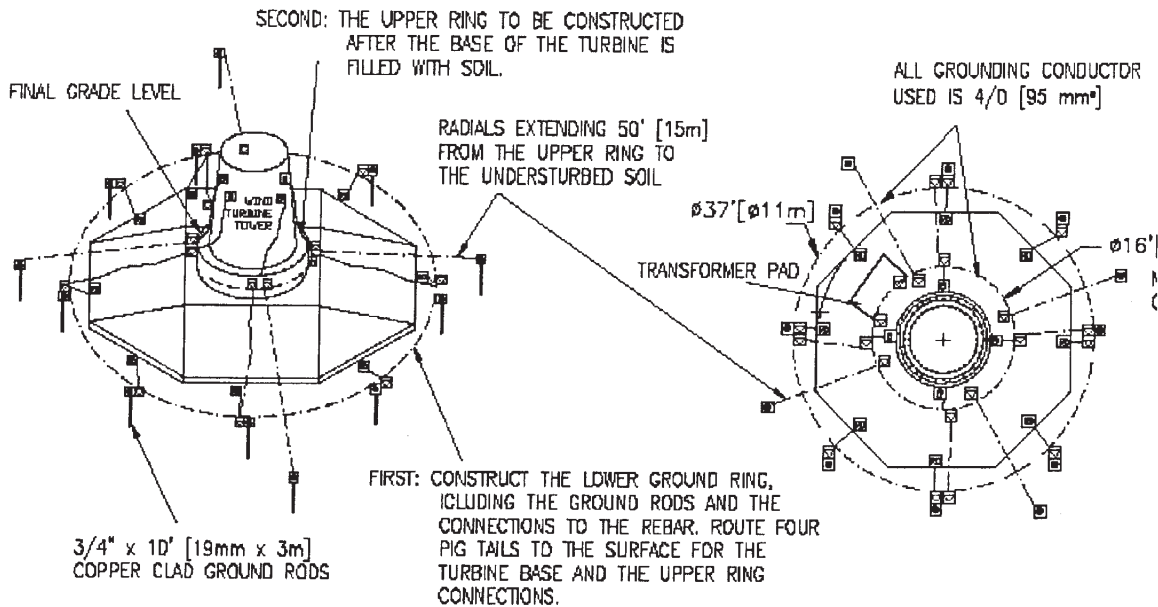

Figure 3 Typical grounding layout.

PERSONAL SAFETY

Wind turbines are in principle safe to work in. However, during thunderstorms personnel working on wind turbines can be exposed to additional risks. For unprotected wind turbines all lightning flashes are potentially harmful to personnel, therefore lightning protection should be part of the turbine design. Work should not be performed on wind turbines during thunderstorms. Safe operating procedures should include precautions for personnel safety during thunderstorms. The risks related to personnel safety at the different locations in a wind turbine during thunderstorms are addressed in detail within IEC 61400-24.

It is vital to consider the safety of the turbine operators and maintenance personnel. This would include:

- o The nacelle cover should provide maximum protection of personnel and sensors inside from direct strike (having metal in the nacelle cover to act as terminals, conductor to ground and Faraday shield)
- o Control boxes should be similarly protected (e.g., operators should be protected against direct strike when working on the boxes)

780-19 Log #6 **Final Action: Reject** (4.8.8.3)

Submitter: Matthew Caie, ERICO, Inc.

Comment on Proposal No: 780-42

Recommendation: None.

Substantiation: The Comment to be made here reflects that of the comment made for 780-35, Log #83 however the more stringent guidelines are necessary. Given that this section refers to chimneys and vents, protrusions such as these on roof-tops constitute higher probability strike points. The point is that there is observed evidence of such damage occurring, this was submitted at and before the ROP.

Committee Meeting Action: Reject

Committee Statement: The submitter did not provide a recommendation for consideration in accordance with the Regulations Governing committee Projects, Section 4-3.3(c).

Number Eligible to Vote: 30**Ballot Results:** Affirmative: 25 Abstain: 1**Ballot Not Returned:** 4 Dyl, D., Heary, W., Rapp, R., Reehl, D.**Explanation of Abstention:**

KAISER, B.: See My Explanation of Abstention on 780-1 (Log #5).

780-20 Log #31 Final Action: Accept in Principle (4.8.8.3)**Submitter:** John M. Tobias, US Army CELCMC**Comment on Proposal No:** 780-42**Recommendation:** See the following figures:

Existing:

4.8.8.3 Required strike termination devices shall be installed on chimneys and vents, as shown in Figure 4.8.8.3, so that the distance from a strike termination device to an outside corner or the distance perpendicular to an outside edge shall be not greater than 0.6 m (2 ft).

Figure 4.8.8.3 [Existing Figure 4.8.8.3, 2004 ed., (no change)]

Change to:

4.8.8.3 Required strike termination devices shall be installed on Class I chimneys and vents (under 75 feet in height above grade), as shown in Figure 4.8.8.3a, so that the distance from a strike termination device to an outside corner or the distance perpendicular to an outside edge shall be not greater than 0.6 m (2 ft).

Required strike termination devices shall be installed on Class II (greater than 75 ft. in height above grade) chimneys and vents, as shown in Figure 4.8.8.3b, so that the distance from a strike termination device to an outside corner or the distance perpendicular to an outside edge shall be not greater than the height of the device above the protected chimney or vent.

Figure 4.8.8.3a [Existing Figure 4.8.8.3, 2004 ed., (no change)]

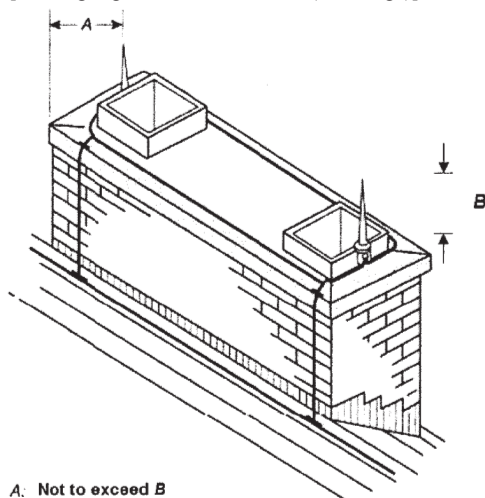

A. Not to exceed B

Figure 4.8.8.3(b)

Note: Air terminal tip configurations can be sharp or blunt

Substantiation: Information presented at May 2005 Pre-ROP meeting indicated that there are a number of ‘bypasses’ where corners of buildings are struck despite the presence of a strike termination. Using other sources (for example derived from Tobias, J. M., ed., *The Basis of Conventional Lightning Protection Technology*, Federal Interagency Lightning Protection Group, Available on www.stinet.dtic.mil, Report No. ADA396784, p. 21, June 2001) the effective protection angle for short distances is agreed to be 45 degrees. By requiring that the air terminal is placed at a distance not to exceed its height above the protected object, the 45 degree protection angle is enforced.

Also see A2007 ROP and comments to 780-35.

Rejection of the original proposal 780-42 leaves an established gap in lightning protection for the taller structures. Yet, the proposal as originally written was too restrictive for Class I structures. (See voting explanations in ROP 2007). This comment addresses the need to place air terminals closer to a roof edge for Class II structures in order to minimize the possibility of bypass attachment to a roof edge. In addition, this comment brings NFPA 780 air terminal placement requirements into closer coordination with IEC lightning protection standards.

Committee Meeting Action: Accept in Principle

Add * following 4.8.8.3.

Add A.4.8.8.3 to read as follows:

A.4.8.8.3 Strike termination devices should be placed as close as practicable to an outside corner.

Committee Statement: The committee intends to retain the text of 4.8.8.3.

Annex material was added to encourage placement of air terminals at corners. The change satisfies the submitter’s intent.

Number Eligible to Vote: 30**Ballot Results:** Affirmative: 25 Abstain: 1**Ballot Not Returned:** 4 Dyl, D., Heary, W., Rapp, R., Reehl, D.**Explanation of Abstention:**

KAISER, B.: See My Explanation of Abstention on 780-1 (Log #5).

780-21 Log #39 Final Action: Reject (4.8.8.3)**Submitter:** Mark P. Morgan, East Coast Lightning Equipment, Inc.**Comment on Proposal No:** 780-42**Recommendation:** The Committee’s rejection of this proposal is correct.

Substantiation: Contrary to the assertion by M. Caie in his Explanation of Negative vote on this proposal, no air terminal bypasses on chimneys or vents installed with NFPA 780 compliant systems was contained in the F. D’Alessandro information referenced as substantiation for this proposal.

Committee Meeting Action: Reject

Committee Statement: The submitter did not provide a recommendation for consideration in accordance with the Regulations Governing committee Projects, Section 4-3.3(c).

Number Eligible to Vote: 30**Ballot Results:** Affirmative: 25 Abstain: 1**Ballot Not Returned:** 4 Dyl, D., Heary, W., Rapp, R., Reehl, D.**Explanation of Abstention:**

KAISER, B.: See My Explanation of Abstention on 780-1 (Log #5).

780-22 Log #1 Final Action: Accept (4.8.8.5)**Submitter:** Harold VanSickle, III, Lightning Protection Institute**Comment on Proposal No:** 780-43**Recommendation:** Revise text to read as follows:

“...shall be located on opposite sides or separated as far apart as practicable...”

Substantiation: The statement “on opposite sides or separated” adds nothing. The balance of the wording will stand alone. The Committee removed similar wording from other proposals because it doesn’t apply well to circular or 5 sided structure housings.

Committee Meeting Action: Accept**Number Eligible to Vote: 30****Ballot Results:** Affirmative: 25 Abstain: 1**Ballot Not Returned:** 4 Dyl, D., Heary, W., Rapp, R., Reehl, D.**Explanation of Abstention:**

KAISER, B.: See My Explanation of Abstention on 780-1 (Log #5).

780-23 Log #33 Final Action: Reject (4.9.3.1)**Submitter:** Melvin K. Sanders, Ankeny, IA**Comment on Proposal No:** 780-44a**Recommendation:** Section 4.9.3.2 should be deleted.

Substantiation: I agree with Mr. Guthrie that use of handrails and ladders for down conductors allow for removal by persons unfamiliar with their secondary purpose. There is a potential for personnel shock due to electrostatic charge build-up or rapid discharge via lightning. In addition, it also mandates additional splices that may affect the charge path to earth, and places them in locations where normal maintenance and accessibility may allow unknowing damage to occur. I believe the text was added in the 2004 edition with little technical substantiation other than it was being done in some locations.

Committee Meeting Action: Reject

Committee Statement: See Committee Action and Statement on 780-4 (Log #22).

Number Eligible to Vote: 30**Ballot Results:** Affirmative: 24 Negative: 1 Abstain: 1**Ballot Not Returned:** 4 Dyl, D., Heary, W., Rapp, R., Reehl, D.**Explanation of Negative:**

GUTHRIE, M.: See comment on ROC 780-4. I concur with Mr. Sanders’ observation that there is a risk of a necessary down conductor being removed and/or the risk of dangerous touch voltage hazards associated with the substitution of these items as down conductors unless some warning signage or insulation is provided.

Explanation of Abstention:

KAISER, B.: See My Explanation of Abstention on 780-1 (Log #5).

780-24 Log #41 **Final Action: Accept**
(5.2.3 (New))

Submitter: Mark P. Morgan, East Coast Lightning Equipment, Inc.
Comment on Proposal No: 780-84
Recommendation: This proposed addition to the standard should be rejected.
Substantiation: For the reasons stated in the negative vote explanations submitted by T. Portfleet and M. Morgan, the Committee should reconsider its decision on this proposal. The new paragraph is vague and ill-defined. It is likely to create confusion as to what items do and do not fall under this paragraph's intent. Specifically, what constitutes "premises", do light poles constitute masts and how should a flag pole that is not equipped with a grounding electrode be dealt with?
Committee Meeting Action: Accept
Number Eligible to Vote: 30
Ballot Results: Affirmative: 25 Abstain: 1
Ballot Not Returned: 4 Dyl, D., Heary, W., Rapp, R., Reehl, D.
Explanation of Abstention:
 KAISER, B.: See My Explanation of Abstention on 780-1 (Log #5).

780-25 Log #21 **Final Action: Accept in Principle**
(Figure 7.3.3.4)

Submitter: Mitchell Guthrie, Blanch, NC
Comment on Proposal No: 780-96
Recommendation: Change the proposed upper case "D" in the formula in Note 1 of Figure 4.7.3.3 to "2R".
 Change "D" to "R" in the legend where "R = rolling sphere radius [30 m (100 ft)]"
 Add "1." before "The distance can be determined ..." in the note provided in the Figure.
Substantiation: The committee action results in both a lower and upper case "d" in the equation. There was some discussion during the ROP meeting that there was confusion by some casual users of the formula as to the source of the value of 200 used in the formula. The substitution of the variable "D" resolves this confusion. However, the use of the variable "2R" in place of "D" (where R is the striking distance) would be even clearer as to the source and it would eliminate the need to use both an upper case and lower case "d" in the formula.

There is no indication that Note 2 is to be removed from Figure 7.3.3.4 and the title is plural ("Notes"), but there is no "1" before the text provided in the figure.

Committee Meeting Action: Accept in Principle
 Change the proposed upper case "D" in the formula in Note 1 of Figure 7.3.3.4 to "2R".
 Change "D" to "R" in the legend where "R = rolling sphere radius (30 m (100 ft.))".
Committee Statement: A reference to Note 1 is not required as there is not a note 2.
Number Eligible to Vote: 30
Ballot Results: Affirmative: 25 Abstain: 1
Ballot Not Returned: 4 Dyl, D., Heary, W., Rapp, R., Reehl, D.
Explanation of Abstention:
 KAISER, B.: See My Explanation of Abstention on 780-1 (Log #5).

780-26 Log #10 **Final Action: Accept**
(8.1.3)

Submitter: Mitchell Guthrie, Blanch, NC
Comment on Proposal No: 780-98
Recommendation: Revise 8.1.3 as follows:
 8.1.3 A lightning protection system lowers, but does not eliminate, risk to personnel and the watercraft and its occupants.
 This proposal is also intended to supersede action taken on ROP 780-98a.
Substantiation: Editorial.
Committee Meeting Action: Accept
Committee Statement: In regards to Proposal 780-98a, the committee agrees with the submitter to change "personnel" to "occupants" relative to 8.1.3 only.
Number Eligible to Vote: 30
Ballot Results: Affirmative: 25 Abstain: 1
Ballot Not Returned: 4 Dyl, D., Heary, W., Rapp, R., Reehl, D.
Explanation of Abstention:
 KAISER, B.: See My Explanation of Abstention on 780-1 (Log #5).

780-27 Log #42 **Final Action: Hold**
(8.1.3 and Annex L)

Submitter: Mitchell A Guthrie, Independent Engineering Consultant
Comment on Proposal No: 780-97
Recommendation: Revise text to read as follows:
 "A.8.1.3 Annex L can be used as a guide in quantifying the level of risk associated with the level of protection provided in the application."
 Add the following revision to Annex L to provide the level of assessment required for this application:
 "L.1 General. This Lightning Risk Assessment methodology is provided to assist the building owner, safety professional, or architect/engineer in determining the risk of damage due to lightning. This annex provides a simplified, quick-look risk assessment (Annex L.5) and a more detailed assessment for those requiring a more detailed analysis (Annex L.6). Once the risk has been determined, the development of protection measures can begin. The methodology considers only the damage caused by a direct strike to the building of structure to be protected and the currents flowing through the lightning protection system.

L.1.1 There are some cases where the need for protection should be given serious consideration regardless of the outcome of the risk assessment. Examples are those applications where the following are factors:

- (1) Large crowds
 - (2) Continuity of critical services
 - (3) High lightning flash frequency
 - (4) Tall isolated structure
 - (5) Building containing explosive or flammable materials
 - (6) ~~Building containing irreplaceable cultural heritage~~
- Delete L.1.2 and Table L.1.2
 Renumber existing L.1.3 through L.1.5 as L.1.2 through L.1.4.
 L.2 through L.4 remains unchanged.

Change title of L.5 from "Tolerable Lightning Frequency" to "Simplified Risk Assessment" and revise the text as follows:

"L.5 Simplified Risk Assessment.
 L.5.1 General. The methodology for a simplified risk assessment is described in this section. The objective is to calculate the tolerable lightning frequency (N_c) and compare it to the expected lightning strike frequency as calculated according to Clause L.3. The tolerable lightning frequency (N_c) is a measure of the risk of damage to the structure including factors affecting risks to the structure, environment, and monetary loss. It is calculated by dividing the acceptable frequency of property losses by various coefficients relating to the structure, the contents, and the consequence of damage. The acceptable frequency of property losses may be set by the authority having jurisdiction or a default value of 1.5×10^{-3} may be used. The coefficient value (C) used in the denominator is the product of the component coefficients where $C = (C_2)(C_3)(C_4)(C_5)$. The values of C_2 through C_5 are obtained from Table L.5.1(a) through Table L.5.1(d)
 Renumber Tables L.5(a), Table L.5(b), Table L.5(c), and Table L.5(d) as Table L.5.1(a), Table L.5.1(b), Table L.5.1(c), and Table L.5.1(d).
 Renumber L.6 as L.5.2 and rename "Risk Calculation."
 Renumber L.6.1, L.6.2, L.6.3, and L.6.4 as L.5.2.1, L.5.2.2, L.5.2.3, and L.5.2.4. Change title of Table L.6.4 to: "Table L.5.2.4 Determination of Protection System Requirement"
 Change L.6.4 to read as follows:
 "L.5.2.4 Table L.5.2.4 provides a simple method of calculating and using the simplified assessment methods described in Annex L.5."

Add new L.6 as follows:
 "L.6 Detailed Assessment.

L.6.1 Introduction. The methodology described in this clause involves the calculation of the risk of losses due lightning with the tolerable level of risk. The procedure involves the comparison of the evaluated risk to the tolerable or acceptable risk to a structure. These assessments will provide a risk for lightning discharges to cause a loss of human life (or living beings), a loss of cultural heritage, and economic losses. Providing three risk factors will allow a facility owner or manager to make an informed decision as to the benefits of providing lightning protection for the structure based on a more diverse set of factors.

L.6.2 Values of Tolerable Risk, R. Values of tolerable levels of loss may be selected by the authority having jurisdiction. Some default values that may be used where levels are not provided by the authority having jurisdiction are given in Table L.6.3.

| Table L.6.3 Typical Values of Tolerable Risk | |
|--|-----------|
| Type of Loss | $R, /yr$ |
| Loss of human life or injury | 10^{-5} |
| Loss of service to the public | 10^{-3} |
| Loss of cultural heritage | 10^{-3} |

L.6.3 Types of Risk Due to Lightning. The types of risk due to lightning for a particular structure or facility may include one or more of the following:

- (a) R1 - risk of loss of human life or injury
- (b) R2 - risk of loss of service to the public
- (c) R3 - risk of loss of cultural heritage
- (d) R4 - risk of loss of economic value

These risk categories are composed of risk components that are summed to determine the overall risk of the loss in a given application. The risk components are characterized according to the type of loss and source of the threat. Threats to be considered in the assessment are associated with:

- flashes to the structure
- flashes to a service entering a structure
- flashes near a service, and
- flashes near a structure

L.6.4 Risk Components. Relevant risk components to be considered in the assessment of the risk of the losses identified in L.6.3 are identified in 6.4.1 through 6.4.4. They are categorized according to the cause of the damage.

L.6.4.1 Lightning strikes directly to a structure

- R_A - injury to humans due to flashes to a structure (touch and step potentials)

- R_B - damage to structure due to direct strike to a structure
- R_C - failure of internal systems due to flashes to a structure

L.6.4.2 Flashes to a connected service

- R_U - injury to humans due to flashes to connected service
- R_V - damage to structure due to flashes to connected service
- R_W - failure of internal systems due to flashes to connected service

L.6.4.3 Flashes near a connected service

- R_Z - failure of internal systems due to flashes near a service

L.6.4.4 Flashes near a structure

- R_M - failure of internal systems due to flashes near a structure

L.6.5 Calculation of Risk. Each component of risk R_x depends on the number of dangerous events N_x (strikes in the area of interest), the probability of damage P_x (or shock to living beings), and the expected loss related to the event L_x . The value of each component of risk R_x may be calculated using the following expression:

$$R_x = N_x \times P_x \times L_x$$

where:

N_x = average number of lightning strikes affecting the structure or service

P_x = probability of damage

L_x = loss factor

L.6.6 Procedure for Risk Assessment and Management. The procedure for the risk assessment is to first identify the structure or facility to be evaluated. This involves defining the extent of the facility or structure being assessed. The structure or facility will be a standalone structure in most cases. The structure may encompass a building and its associated outbuildings or equipment support structures. One must then determine all relevant physical, environmental, and service installation factors applicable to the structure.

The second step is to identify all the types of loss relevant to the structure or facility. For most structures, only R_1 and R_3 may need to be considered. R_2 will apply to museums, galleries, libraries, churches, and heritage listed buildings. For each type of loss relevant to the structure, choose the relevant loss factors.

Next, determine the maximum tolerable risk (R_t) for each relevant type of loss for the structure by identifying the components (R_x) that make up the risk, calculate the identified components of risk, and calculate the total risk due to lightning (R).

Compare the total risk (R) with the maximum tolerable risk (R_t) for each type of loss relevant to the structure. If $R < R_t$ for each type of loss relevant to the structure than lightning protection may not be needed."

Substantiation: The proposed text of 8.1.3 correctly cautions that the protection detailed in the chapter reduces but does not eliminate the risk to watercraft and its occupants; but it does not provide information as to how one could determine the overall risk. This proposal attempts to provide guidance to the user in determining the risk and provides a proposed revision to Annex L to provide a sufficient level of assessment adequate to cover the application.

Committee Meeting Action: Hold

Committee Statement: Changes have been made to the text to the point that the committee needs to restudy the text.

This cannot be properly handled within the time frame for processing the report.

Number Eligible to Vote: 30

Ballot Results: Affirmative: 23 Abstain: 3

Ballot Not Returned: 4 Dyl, D., Heary, W., Rapp, R., Reehl, D.

Explanation of Abstention:

CAIE, M.: The comment for the change in vote is as follows:

Significant constructive changes were made during the ROC Meeting that would have made the detailed assessment a valuable tool and much needed addition to the standard. I do not agree with the decision to hold the proposal for the next cycle. The proposal reviewed at the ROC brings the assessment in line with the internationally approved assessment incorporated into IEC 62305-2 and other national standards such as British, French, Australian and many other national standards participating in the IEC lightning protection standard. I agree we are doing a disservice to those requiring a more detailed assessment by holding this revision for the next cycle, the proposal was part of an internationally approved assessment methodology.

GUTHRIE, M.: I do not concur with the decision to hold the proposal for the next cycle. The majority of the negative discussion was associated with the existing text in Annex L and this will not be corrected by holding the proposal to the next cycle. Significant constructive changes were made during the ROC meeting that would have made the detailed assessment a valuable tool to those state and federal agencies that have indicated that they use the NFPA 780 Annex L assessment for such critical applications such as DOE sites,

Department of Defense explosives facilities, hospitals, and schools. By holding this proposal, each of these critical assessments will be conducted for the next 4 years using an assessment far below the level of detail available and necessary for such applications. While it is understood that the committee is concerned with the level of detail proposed during the meeting, the changes made bring the assessment in line with the internationally approved assessment incorporated into IEC 62305-2 and other national standards such as the French and Australian lightning protection standards. I believe we are doing a disservice to those requiring a detailed assessment by holding this revision for the next cycle because we are uncomfortable accepting an internationally approved assessment methodology.

KAISER, B.: See My Explanation of Abstention on 780-1 (Log #5).

780-28 Log #20 **Final Action:** Accept
(8.3.1.2 and Figure 8.3.1.2)

Submitter: Mitchell Guthrie, Blanch, NC

Comment on Proposal No: 780-97

Recommendation: Delete Figure 8.3.1.2(a) as it is identical to Figure 7.3.3.4.

Change the reference in 8.3.1.2 from "Figure 8.3.1.2(a)" to "Figure 7.3.3.4."

Figure 8.3.1.2(b) will become Figure 8.3.1.2.

Substantiation: Figure 8.3.1.2(a) is identical to Figure 7.3.3.4. It is not necessary to have a new figure in each chapter if they are identical. It is recommended that this figure be deleted and new Figure 8.3.1.2 will be limited to existing Figure 8.3.1.2(b).

Committee Meeting Action: Accept

Number Eligible to Vote: 30

Ballot Results: Affirmative: 25 Abstain: 1

Ballot Not Returned: 4 Dyl, D., Heary, W., Rapp, R., Reehl, D.

Explanation of Abstention:

KAISER, B.: See My Explanation of Abstention on 780-1 (Log #5).

780-29 Log #19 **Final Action:** Accept
(8.3.3.5)

Submitter: Mitchell Guthrie, Blanch, NC

Comment on Proposal No: 780-97

Recommendation: Delete 8.3.3.5 as it deals with grounding requirements in a strike termination section. Applicable requirements are given in Section 8.5.

Substantiation: Applicable requirements are given in Section 8.5. This section deals with strike termination on non-metallic masts, not grounding.

Committee Meeting Action: Accept

Number Eligible to Vote: 30

Ballot Results: Affirmative: 25 Abstain: 1

Ballot Not Returned: 4 Dyl, D., Heary, W., Rapp, R., Reehl, D.

Explanation of Abstention:

KAISER, B.: See My Explanation of Abstention on 780-1 (Log #5).

780-30 Log #18 **Final Action:** Accept
(8.4.4.2)

Submitter: Mitchell Guthrie, Blanch, NC

Comment on Proposal No: 780-97

Recommendation: Revise 8.4.4.2 as follows:

8.4.4.2 Each interconnection shall consist of employ at least a bonding conductor no smaller than a bonding conductor as described in 8.4.2; or a connecting fitting satisfying the requirements in Section 8.4.6, and each joint between conductors shall satisfy the requirements in Section 8.4.5.

Substantiation: Editorial and clarification of intent.

Committee Meeting Action: Accept

Number Eligible to Vote: 30

Ballot Results: Affirmative: 25 Abstain: 1

Ballot Not Returned: 4 Dyl, D., Heary, W., Rapp, R., Reehl, D.

Explanation of Abstention:

KAISER, B.: See My Explanation of Abstention on 780-1 (Log #5).

780-31 Log #17 **Final Action:** Accept
(8.5.2.2)

Submitter: Mitchell Guthrie, Blanch, NC

Comment on Proposal No: 780-97

Recommendation: Reference to 8.5.4.3 should be 8.5.5.3.

Substantiation: Editorial.

Committee Meeting Action: Accept

Number Eligible to Vote: 30

Ballot Results: Affirmative: 25 Abstain: 1

Ballot Not Returned: 4 Dyl, D., Heary, W., Rapp, R., Reehl, D.

Explanation of Abstention:

KAISER, B.: See My Explanation of Abstention on 780-1 (Log #5).

**780-32 Log #16 Final Action: Accept
(8.5.5)**

Submitter: Mitchell Guthrie, Blanch, NC
Comment on Proposal No: 780-97

Recommendation: The text contained after the heading is annex material and not properly displayed as such in the ROP. The text should read as follows:
8.5.5* Galvanic Corrosion Protection.

A.8.5.5 An air gap or SPD (such as a gas discharge tube) may be desirable to reduce corrosion in the presence of leakage currents in the water and may reduce galvanic corrosion. However, using an air gap to isolate an immersed conductor from the water may increase the risk of a ground fault current bypassing any ground fault protection device. Hence a hazardous current can be inadvertently introduced into the water. For this reason measures should be taken to ensure that loose electrical connections cannot contact any part of the isolated grounding electrode. A spark gap should not be used where there is the possibility of ignitable vapors or personnel hazards.

Substantiation: Editorial.

Committee Meeting Action: Accept

Number Eligible to Vote: 30

Ballot Results: Affirmative: 25 Abstain: 1

Ballot Not Returned: 4 Dyl, D., Heary, W., Rapp, R., Reehl, D.

Explanation of Abstention:

KAISER, B.: See My Explanation of Abstention on 780-1 (Log #5).

**780-33 Log #9 Final Action: Accept
(A.4.1.14.1)**

Submitter: Mitchell Guthrie, Blanch, NC
Comment on Proposal No: 780-103

Recommendation: It is agreed to spell out spark over voltage as proposed in the committee proposal but the appropriate symbol should be provided in parentheses as it will appear in SPD data sheets rather than the wording. Revise last sentence of committee revision as follows to reflect this change and correct the editorial error that the “8” is not shown as an exponent:

“The devices used in these applications should be rated at a maximum discharge current no less than 100 kA, 8/20 μs (2.5 kV spark over voltage (U_p)), have an isolating resistance no less than 10⁸ ohms and a maximum DC spark over voltage of 500 volts.”

Substantiation: The symbol U_p is likely to be more prominent in SPD data sheets than the wording “spark over voltage” so it should be included in the text. Other changes are editorial.

Committee Meeting Action: Accept

Committee Statement: The committee notes that the submitter incorrectly referenced the print line to A.4.1.14.1. The correct reference is to A.4.14.1.

Number Eligible to Vote: 30

Ballot Results: Affirmative: 25 Abstain: 1

Ballot Not Returned: 4 Dyl, D., Heary, W., Rapp, R., Reehl, D.

Explanation of Abstention:

KAISER, B.: See My Explanation of Abstention on 780-1 (Log #5).

**780-33a Log #CC2 Final Action: Accept
(A.4.18.4, 3.3.36, A.3.3.36 and A.3.3.28)**

Submitter: Technical Committee on Lightning Protection,
Comment on Proposal No: 780-105

Recommendation: Change A.4.18.4 to read as follows:

A.4.18.4 The measured limiting voltages of the SPD should be selected to limit damage to the service or equipment protected.

Devices rated in accordance with UL 1449, Edition 3 will reflect a Voltage Protection Rating (VPR) in place of the SVR. This is to reflect that the voltage rating test in the 3rd Edition will utilize a 3 kA peak current instead of the 500 A current level used in the SVR test of UL 1449, Edition 2.

Change 3.3.36 to read as follows:

3.3.36 Voltage Protection Rating (VPR). A rating (or ratings) selected by the manufacturer based on the measured limiting voltage determined when the SPD is subjected to a combination waveform with 6 kV open circuit voltage and 3 kA short circuit current. The value is rounded up to the next highest 100 V level.

Delete A.3.3.36.

~~A.3.3.36 Voltage Protection Level (VPL). This VPL is not the same as the Voltage Protection Level (Up) in IEC 61643-1. Up is determined at In (which the manufacturer can nominate), while VPL is determined at a fixed value of 3 kA, 8/20 μs for all SPDs.~~

Change A.3.3.28 to read as follows:

A.3.3.28 Suppressed Voltage Rating (SVR). A rating (or ratings) selected by the manufacturer based on the measured limiting voltage determined during the transient-voltage surge suppression test specified in UL 1449, UL Standard for Safety Transient Voltage Surge Suppressors. This rating is the maximum voltage developed when the SPD is exposed to a 500 A, 8/20 μs current limited waveform through the device. It is a specific measured limiting voltage rating assigned to a TVSS by testing done in accordance with UL 1449. Nominal SVR values include 330 V, 400 V, 500 V, 600 V, 700 V, and so forth.

Devices rated in accordance with UL 1449, Edition 3 will reflect a Voltage

Protection Rating (VPR) in place of the SVR. This is to reflect the difference that the voltage rating test will utilize a 3 kA peak current instead of the 500 A current level used in the SVR test of UL 1449, Edition 2.

Substantiation: The committee changes the text of A.4.18.4 to correlate with the requirements of UL 1449, 3rd Edition.

Committee Meeting Action: Accept

Number Eligible to Vote: 30

Ballot Results: Affirmative: 25 Abstain: 1

Ballot Not Returned: 4 Dyl, D., Heary, W., Rapp, R., Reehl, D.

Explanation of Abstention:

KAISER, B.: See My Explanation of Abstention on 780-1 (Log #5).

Comment on Affirmative:

GUTHRIE, M.: The specific text of A.3.3.36 to be deleted should be identified in the comment. There is no existing A.3.3.36 and none identified in the ROP or ROC. The public not having access to the ROP modified draft will not be able to identify what text is to be deleted.

**780-34 Log #15 Final Action: Accept
(A.8.3.2.1)**

Submitter: Mitchell Guthrie, Blanch, NC
Comment on Proposal No: 780-97

Recommendation: Add additional text as follows to cover retrofit applications and other applications where a modification of the owner’s manual is not practical:

For retrofit applications and those applications where a sufficient zone of protection cannot be provided, the zone of protection of the lightning protection system shall be identified and provided to the user of the watercraft.

Substantiation: The scope of this chapter is not given, but it is assumed that it may be applicable for both retrofit and new construction. For retrofit applications, it may not be practical to modify the owner’s manual. It is also recommended that the zone of protection be provided and kept with the watercraft in all cases as this would identify preferred locations for personnel.

Committee Meeting Action: Accept

Number Eligible to Vote: 30

Ballot Results: Affirmative: 25 Abstain: 1

Ballot Not Returned: 4 Dyl, D., Heary, W., Rapp, R., Reehl, D.

Explanation of Abstention:

KAISER, B.: See My Explanation of Abstention on 780-1 (Log #5).

**780-35 Log #14 Final Action: Accept
(A.8.4.2.3)**

Submitter: Mitchell Guthrie, Blanch, NC
Comment on Proposal No: 780-97

Recommendation: Change “A8.4.1.3” to “A.8.4.1.3”.

Substantiation: Editorial.

Committee Meeting Action: Accept

Number Eligible to Vote: 30

Ballot Results: Affirmative: 25 Abstain: 1

Ballot Not Returned: 4 Dyl, D., Heary, W., Rapp, R., Reehl, D.

Explanation of Abstention:

KAISER, B.: See My Explanation of Abstention on 780-1 (Log #5).

**780-36 Log #13 Final Action: Accept in Principle
(A.8.4.6.2)**

Submitter: Mitchell Guthrie, Blanch, NC
Comment on Proposal No: 780-97

Recommendation: Change “A8.4.1.4” to “A.8.4.1.4” in A.8.4.6.2(1).

Substantiation: Editorial.

Committee Meeting Action: Accept in Principle

Change “A8.4.1.4” to “A.8.4.1.4” in A.8.4.6.2(1).

Change “A8.4.1.3” to “A.8.4.1.3” within the text of A.8.4.2.3 and A.8.4.2.4.

Committee Statement: The committee accepts the submitter’s recommendation and corrects additional typos. The change satisfies the submitter’s intent.

Number Eligible to Vote: 30

Ballot Results: Affirmative: 25 Abstain: 1

Ballot Not Returned: 4 Dyl, D., Heary, W., Rapp, R., Reehl, D.

Explanation of Abstention:

KAISER, B.: See My Explanation of Abstention on 780-1 (Log #5).

780-37 Log #12 **Final Action: Accept**
(A.8.5.2.1)**Submitter:** Mitchell Guthrie, Blanch, NC**Comment on Proposal No:** 780-97**Recommendation:** Revise A.8.5.2.1 as follows:

A.8.5.2.1 In order to allow for main conductors to be routed externally to vulnerable areas; (as described in Section 8.4. 1.6); ~~but also to and~~ reduce the risk of external side flashes from the lightning conductors, grounding electrodes should be located as close to the waterline as is practicable. Where an onboard fitting is below the waterline and close to the water, an additional supplemental grounding electrode is advisable in the vicinity of the fitting.

Substantiation: Editorial and clarification of intent.**Committee Meeting Action:** Accept**Number Eligible to Vote:** 30**Ballot Results:** Affirmative: 25 Abstain: 1**Ballot Not Returned:** 4 Dyl, D., Heary, W., Rapp, R., Reehl, D.**Explanation of Abstention:**

KAISER, B.: See My Explanation of Abstention on 780-1 (Log #5).

780-38 Log #3 **Final Action: Accept in Principle**
(Annex B)**Submitter:** Franco D'Alessandro, ERICO products Australia Pty Ltd**Comment on Proposal No:** 780-110**Recommendation:** Reconsider ROP 780-110.

Substantiation: The extended Annex B was rejected on the basis that the material was "outside the Scope of the NFPA document", that it "did not support the material in the main body of the standard" and the "volume of annex material was too large". However, there is a lot of annex material in the standard presently, some old and some new and approved at the ROP meeting, which also fits these criteria.

It is requested that this annex is revisited in an appropriate manner at the ROC meeting. If, as appears to be the case, the committee feels the above criteria are valid, then the following should take place:

1. The whole standard should be reviewed for any material that is not in the Scope or does not support the main body of the document. Any sections identified using these criteria should be deleted. [**Reason:** For consistency with the NFPA policy outlined in the February '06 ROP meeting and summarized above].

2. The information exchange and decision-making process between the main committee and task forces needs to be reviewed and improved. [**Reason:** During the revision cycle, the Modelling Task Force spent a considerable amount of time and energy discussing the extension of Annex B. This work was undertaken after general consensus was reached within the main committee that there was a need for additional explanatory material in this annex. However, in the February '06 ROP meeting, all of the additional explanatory material was rejected, literally in a matter of minutes, without consideration of how this material improved the standard. Clearly, this was a communication issue or some other problem].

Committee Meeting Action: Accept in Principle**Committee Statement:** See Committee Action and Statement on 780-39 (Log #32).**Number Eligible to Vote:** 30**Ballot Results:** Affirmative: 22 Negative: 3 Abstain: 1**Ballot Not Returned:** 4 Dyl, D., Heary, W., Rapp, R., Reehl, D.**Explanation of Negative:**

MELTON, JR., R.: The following comment applies to each of the above since each refers directly to the original proposal, 780-110.

While the extended Annex B may(?) be "outside the scope of the NFPA document", I believe it is very important for those "users" of 780 to be able to read a technical summary of the rationale used in the preparation of the 780 standard. This would apply to both designers and installers of lightning protection systems. This serves to add both substantiation and credibility to the guidelines in 780 as opposed to stating "do it this way". Stating that there are various references that are already available as an alternative would not be a satisfactory response. I believe it is valuable to contain this information in Annex B, as proposed.

I, therefore, support the inclusion of the Annex B material as proposed in 780-110 by the Modeling Task Force and disagree with the committee's recommendation. This would also include any editorial, formatting and grammatical changes as necessary to make the document fit NFPA structure.

MORGAN, M.: I concur with Mr. W. Rison in his submission to the ROC. I don't believe that this section helps in the design of a lightning protection system or is necessary in an installation standard.

RISON, W.: Comment 780-38 should be rejected. See my Explanation of Negative Vote on Comment 780-39.

Explanation of Abstention:

KAISER, B.: See My Explanation of Abstention on 780-1 (Log #5).

780-39 Log #32 **Final Action: Accept in Principle**
(Annex B)**Submitter:** John M. Tobias, US Army CELCMC**Comment on Proposal No:** 780-110**Recommendation:** Revise text to read as follows:**Annex B: Principles of Lightning Protection**

This annex is not a part of the requirements of this NFPA document but is included for informational purposes only.

B.1 Fundamental Principles of Lightning Protection.

B.1.1 The fundamental principle in the protection of life and property against lightning is to provide a means by which a lightning discharge can enter or leave the earth without resulting damage or loss. A low impedance path that the discharge current will follow in preference to all alternative high impedance paths offered by building materials such as wood, brick, tile, stone, or concrete should be offered. When lightning follows the higher impedance paths, damage may be caused by the heat and mechanical forces generated during the passage of the discharge. Most metals, being good electrical conductors, are virtually unaffected by either the heat or the mechanical forces if they are of sufficient size to carry the current that can be expected. The metallic path must be continuous from the ground terminal to the strike termination device. Care should be exercised in the selection of metal conductors to ensure the integrity of the lightning conductor for an extended period. A nonferrous metal such as copper or aluminum will provide, in most atmospheres, a lasting conductor free of the effects of rust or corrosion.

B.1.2 Parts of structures most likely to be struck by lightning are those that project above surrounding parts such as chimneys, ventilators, flagpoles, towers, water tanks, spires, steeples, deck railings, shafthouses, gables, skylights, dormers, ridges, and parapets. The edges and corners of the roof are the parts most likely to be struck on flat or gently sloping roofed buildings.

B.2 Lightning Protection Systems.

B.2.1 Lightning protection systems consist of the following three basic parts that provide the low impedance metal path required:

(1) A system of strike termination devices on the roof and other elevated locations.

(2) A system of ground terminals.

(3) A conductor system connecting the strike termination devices to the ground terminals. Properly located and installed, these basic components improve the likelihood that the lightning discharge will be conducted harmlessly between the strike termination devices and the ground terminals.

B.2.2 While intercepting, conducting, and dissipating the main discharge, the three basic protection system components do not ensure safety from possible secondary effects of a lightning strike. Therefore, secondary conductors are provided to interconnect metal bodies to ensure that such metal bodies are maintained at the same electrical potential so as to prevent sideflashes or sparkover. Surge suppression devices are also provided to protect power lines and associated equipment from both direct discharges and induced currents.

B.2.3 The structure should be examined, and installation of air terminals should be planned for all areas or parts likely to receive a lightning discharge. The object is to intercept the discharge immediately above the parts liable to be struck and to provide a direct path to earth, rather than to attempt to divert the discharge in a direction it would not be likely to take. The air terminals should be placed high enough above the structure to obviate danger of fire from the arc.

ADD

B.3 Positioning of Air Terminals. Positioning of air terminals depends upon the physical lightning model used to describe the behavior of lightning. The development of these models has been ongoing for two hundred and fifty years and models have a basis in physical observations of lightning. While the models tend to be simplified compared to actual details of lightning development and propagation, empirical observations over hundreds of years have proven their effectiveness.

Air terminals are intended to intercept the lightning event by providing a preferred attachment point for lightning's electrical discharge. They operate by actually providing an upward propagating leader of ionized air to intercept a downward lightning leader. Since these leaders are ionized air of opposite charge, they attract and provide the electrical channel to earth for lightning when they connect. Air terminals placed upon a structure do not substantially increase the probability of the structure being struck by lightning. If the downward progressing lightning leader is close to the structure, it will probably attach to that structure anyway. Thus, air terminals are designed to provide a preferential attachment point on structures that already provide a likely lightning attachment point. Once lightning connects to the air terminal, it is easier to control the lightning current and direct it to earth as opposed to it taking a random, uncontrolled (and usually damaging) path through the structure otherwise.

This section is intended to educate the user of NFPA 780 by providing some background in the mechanics of the lightning models and their reduction into design rules for the placement of air terminals. To begin the discussion, we can start with the physics of lightning attachment.

B.3.1 Physics of Lightning Attachment. The first stroke of a ground flash is normally preceded by a downward-progressing, low-current leader discharge that commences in the negatively charged region of the cloud and progresses towards the earth, depositing negative charges in the air surrounding the leader

discharge channel. (Occasionally, the downward leader can be positive in charge but this does not affect its behavior in terms of attachment.) When the lower end of the leader is 100

– 300 m from the earth or grounded objects, electrical discharges (streamers) are likely to be initiated from prominent points on grounded objects, and to propagate upwards towards the leader discharge channel. Several streamers may start, but usually only one is successful in reaching the downward leader.

The high current phase (return stroke) commences at the moment the upward moving streamer meets and connects with the downward leader. The position in space of the lower portion of the lightning discharge channel is therefore determined by the path of the successful streamer, i.e. the one that succeeded in reaching the downward leader. The primary task in protecting a structure is therefore to ensure a high probability that the successful streamer originates from the air terminals and not from a part of the structure that would be adversely affected by the lightning current that subsequently flows.

As the path of the successful streamer may have a large horizontal component as well as a vertical component, an elevated air terminal will provide protection for objects spread out below it. Within limits, it is therefore possible to provide protection for a large volume with a relatively small number of correctly positioned air terminals. This is the basis for the concept of a “zone of protection” and provides the basic principle underlying interception lightning protection.

Therefore, the function of an air terminal in an LPS is to divert to itself the lightning discharge that might otherwise strike a vulnerable part of the object to be protected. It is generally accepted that the range over which an air terminal can attract a lightning discharge is not constant, but increases with the severity of the discharge.

The path of a lightning discharge near a structure is determined by the path of the successful streamer (see Paragraph B.2.2) that will usually be initiated from a conducting part of the structure nearest to the downward leader. The initiation of streamers is also influenced by the local electric field. Conductive objects with a small radius of curvature will concentrate the electric field. Thus, air terminals, as well as the upper outer edges and corners of buildings or structures, and especially protruding parts, are likely to have higher local electric fields than elsewhere, and are therefore likely places for the initiation of upward streamers. When the downward leader is within about 200 m of the building, the electric field at these protruding parts and corners will exceed the breakdown field strength of air, resulting in corona currents that cause these parts to be surrounded by ionized air. At some point, this ionized air will begin to move in response to the elevated electric field provided by the downward leader. Upward streamers of ionized air will form and move toward the downward leader. Consequently, the most probable strike attachment point on a building is the edge, corner, or other protruding part in the vicinity of the downward leader. Hence, if air terminals are placed at all locations where high electric fields and streamer initiation are likely, there will be a high probability that the discharge will be intercepted successfully.

B.3.2 Overview of Methods. A “design method” is used to identify the most suitable locations placing for strike termination devices, based on the area of protection afforded by each one. There are generally two categories of “placement methods” as used in NFPA 780:

(a) Purely geometrical constructions, such as the “Cone of Protection” or “Protection Angle” method;

(b) Electrogeometric models (EGM’s), in which empirical relationships for striking distance and lightning peak current are invoked. The most common example is the “Rolling Sphere Method”, which is also partly a geometric construction;

B.3.2.1 Cone of Protection (“Protection Angle”) Method. This method is based on the assumption that an air terminal or an elevated, grounded object creates an adjacent, conical space that is essentially immune to lightning, as illustrated in Figure 1. The concept of a cone of sufficient angle to define the protected zone has its roots in the very beginning of lightning protection studies. Although Franklin recognized a limit as to the range of the air terminal in the late 1700’s, the concept was first formally proposed by the French Academy of Science in 1823 and initially used a base of twice the height, i.e., an angle of 63°. By 1855, this angle was changed to 45° due to field reports that the method was failing. Generally, this angle was preserved in standards for more than one hundred years. In some standards today, a variable angle depending on the height of the structure is used.

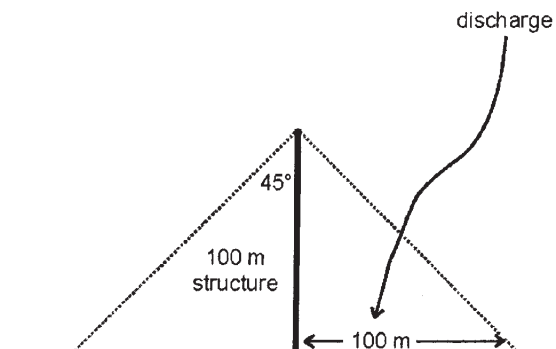

Figure B.1 The “Cone of Protection” method.

It should be noted that the protected space is not totally immune to all lightning discharges. Using the Electrogeometric Model (see section 3.5 for more details), for a downward leader carrying a charge corresponding to a peak stroke current of 10 kA, if it approaches at a lateral distance greater than 45 meters it may bypass the structure and enter the assumed zone of protection of 100 m.

B.3.2.2 Rolling Sphere Method. The Rolling Sphere method is the most common design method, superseding the cone of protection method in NFPA 780 in the 1980 edition. It originated from the electric power transmission industry, i.e., lightning strike attachment to phase and shield wires of lines and is based on the simple Electrogeometric Model. To apply the method, an imaginary sphere, typically 45 m (150 ft) in radius, is rolled over the structure. All surface contact points are deemed to require protection, whilst the unaffected surfaces and volumes are deemed to be protected, as shown in Figure 3.

The physical basis for the Rolling Sphere method is the Electrogeometric Model. Consider a particular peak lightning current I_p (kA) and the corresponding “striking distance” ds (m), where $ds = 10 I_p^{0.65}$ [as reported by Uman]. For a typical peak current of 10 kA, the striking distance is ~ 45 m, i.e., this is the distance at which a downward leader results in the initiation of an upward leader from the structure.

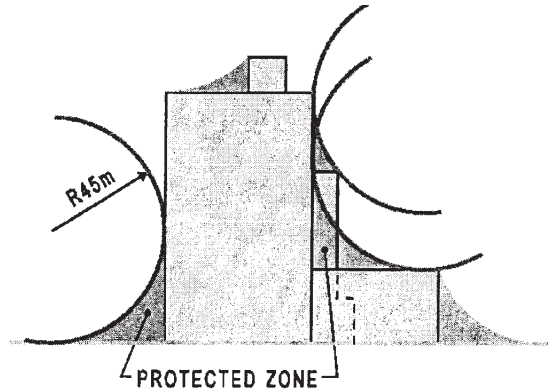

Figure B.3 Lightning protection design using the Rolling Sphere Method.

Note that a smaller striking distance (implying a lower peak current of the lightning event) results in a smaller sphere that can intrude upon the standard 45 meter zone of protection. Thus, more conservative design is to size the sphere using a lower lightning peak current. Lightning peak currents below 5 kA – 7 kA are not realistic, however, and the 10 kA peak current represents 96% to 98% of all lightning events.

The advantage of the RSM is that it is relatively easy to apply, even to buildings with complicated shapes. However, since it is a simplification of the physical process of lightning attachment to a structure, it has some limitations. The main limitation is that it assigns an equal leader initiation ability to all contact points on the structure, i.e., no account is taken of the influence of electric fields in initiating return streamers, so it does not distinguish between likely and unlikely lightning strike attachment points. In other words, for a given prospective peak stroke current, the striking distance ds is a constant value. This simplification stems from its origins in the electrical power transmission industry, where there is considerable uniformity in the parameters of transmission lines (diameters, heights, etc). In reality, lightning may preferentially strike the corner of the building rather than the vertical flat surface half way down the side of the building. The same claims apply to the flat roof of a structure.

Some qualitative indication of the probability of strike attachment to any particular point can be obtained if the sphere is supposed to be rolled over the building in such a manner that its center moves at constant speed. Then the length of time that the sphere dwells on any point of the building gives a qualitative indication of the probability of that point being struck. Thus, for a simple rectangular building with a flat roof, the dwell time would be large at the corners and edges, and small at any point on the flat part of the roof, correctly indicating a higher probability of the corners or edges being struck, and a low probability that a point on the flat part of the roof will be struck.

When the RSM is applied to a building of height greater than the selected sphere radius, then the sphere touches the vertical edges on the sides of the building at all points above a height equal to the sphere radius. This indicates the possibility of strikes to the sides of the building, and raises the question of the need for an air terminal network in these locations. Studies show that strikes to vertical edges on the sides of tall buildings do occur but are not very common. There are theoretical reasons for believing that only flashes with low I_p and consequently low ds values are likely to be able to penetrate below the level of the roof of the building and strike the sides. Hence, the consequences of a strike to the sides of a building may result in damage of a minor nature. Unless there are specific reasons for side protection, as would be the case of a structure containing explosives, it is considered that the cost of side protection would not normally be justified.

B.3.2.3 Other Models and Design Methods. Other lightning models exist and are periodically considered by a NFPA 780 subcommittee for development into design/air terminal placement methods for inclusion into NFPA 780. No further consideration of other models is given here as they do not fall within the scope of NFPA 780.

The sections below need to be renumbered

B.3 Items to Consider When Planning Protection.

B.3.1 The best time to design a lightning protection system for a structure is during the structure's design phase, and the best time to install the system can be during construction. System components can be built in so as to be protected from mechanical displacement and environmental effects. In addition, aesthetic advantages may be gained by such concealment. Generally, it is less expensive to meet lightning protection requirements during construction.

B.3.2 moved up to section B.2

B.3.3 Conductors should be installed to offer the least impedance to the passage of stroke current between the strike termination devices and earth. The most direct path, without sharp bends or narrow loops, is best. The impedance of the conductor system is practically inversely proportional to the number of widely separated paths. Accordingly, there should be at least two paths to ground and more, if practicable, from each strike termination device. The number of paths is increased and the impedance decreased by connecting the conductors to form a cage enclosing the building.

B.3.4 Properly made ground connections are essential to the effective functioning of a lightning protection system, and every effort should be made to provide ample contact with the earth. This does not necessarily mean that the resistance of the ground connection should be low, but rather that the distribution of metal in the earth or upon its surface in extreme cases should be such as to permit the dissipation of a stroke of lightning without damage.

B.3.5 Low resistance is desirable, but not essential, as may be shown by the extreme case on the one hand of a building resting on moist clay soil, and on the other by a building resting on bare solid rock. In the first case, if the soil is of normal resistivity or from 4,000 ohm-centimeters to 50,000 ohm-centimeters, the resistance of a ground connection made by extending the conductor 10 ft (3 m) into the ground will be from about 15 ohms to 200 ohms, and two such ground connections on a small rectangular building have been found by experience to be sufficient. Under these favorable conditions, providing adequate means for collecting and dissipating the energy of a flash without serious chance of damage is a simple and comparatively inexpensive matter.

B.3.6 In the second case, it would be impossible to make a ground connection in the ordinary sense of the term because most kinds of rocks are insulating, or at least of high resistivity, and in order to obtain effective grounding other more elaborate means are necessary. The most effective means would be an extensive wire network laid on the surface of the rock surrounding the building to which the down conductors could be connected. The resistance to earth at some distant point of such an arrangement would be high but at the same time the potential distribution about the building would be substantially the same, as though it were resting on conducting soil, and the resulting protective effect also would be substantially the same.

B.3.7 In general, the extent of the grounding arrangements will depend on the character of the soil, ranging from simple extension of the conductor into the ground where the soil is deep and of high conductivity to an elaborate buried network where the soil is very dry or of very poor conductivity. Where a network is required, it should be buried if there is soil enough to permit it, as this adds to its effectiveness. Its extent will be determined largely by the judgment of the person planning the installation with due regard to the following rule: The more extensive the underground metal available, the more effective the protection.

B.3.8 Where practicable, each ground terminal connection should extend or have a branch that extends below and at least 2 ft (0.6 m) away from the foundation walls of the building in order to minimize the likelihood of damage to foundation walls, footings, and stemwalls.

B.3.9 When a lightning conductor system is placed on a building, within or about which there are metal objects of considerable size within a few feet of a conductor, there will be a tendency for sparks or sideflashes to jump between the metal object and the conductor. To prevent damage, interconnecting conductors should be provided at all places where sideflashes are likely to occur.

B.3.10 Lightning currents entering protected buildings on overhead or underground power lines, or telephone conductors, or television or radio antennas are not necessarily restricted to associated wiring systems and appliances. Therefore, such systems should be equipped with appropriate protective devices and bonded to ensure a common potential.

B.3.11 Because a lightning protection system is expected to remain in working condition for long periods with minimum attention, the mechanical construction should be strong and the materials used should offer resistance to corrosion and mechanical injury.

B.4 Inspection and Maintenance of Lightning Protection Systems.

It has been shown that in cases where damage has occurred to a protected structure, the damage was due to additions or repairs to the building or to deterioration or mechanical damage that was allowed to go undetected and unrepaired, or both. Therefore, it is recommended that an annual visual inspection be made and that the system be thoroughly inspected every five years.

B.5 Indirect Losses. In addition to direct losses such as destruction of buildings by lightning, fire resulting from lightning, and the killing of livestock, indirect losses sometimes accompany the destruction or damage of buildings and their contents. An interruption to business or farming operations, especially at certain times of the year, may involve losses quite distinct from, and in addition to, the losses arising from the direct destruction of material property. There are cases where whole communities depend on the integrity of a single structure for their safety and comfort. For example, a community may depend on a water-pumping plant, a telephone relay station, a police station, or a fire station. A stroke of lightning to the unprotected chimney of a pumping plant might have serious consequences such as a lack of sanitary drinking water, irrigating water, or water for fire protection. Additional information on this topic is available in the documents identified in Appendix M.1.2.1.

Substantiation: Rejection of the original proposal 780-110 was predicated upon the thought that portions were out of scope. Important explanatory material is enclosed in the original proposal. The revision in this comment omits the material considered out of scope.

Committee Meeting Action: Accept in Principle

Replace entire existing Annex B with new Annex B.
Annex B Principles of Lightning Protection

This annex is not a part of the requirements of this NFPA document but is included for informational purposes only.

B.1 Fundamental Principles of Lightning Protection.

B.1.1 The fundamental principle in the protection of life and property against lightning is to provide a means by which a lightning discharge can enter or leave the earth without resulting damage or loss. A low impedance path that the discharge current will follow in preference to all alternative high impedance paths offered by building materials such as wood, brick, tile, stone, or concrete should be offered. When lightning follows the higher impedance paths, damage may be caused by the heat and mechanical forces generated during the passage of the discharge. Most metals, being good electrical conductors, are virtually unaffected by either the heat or the mechanical forces if they are of sufficient size to carry the current that can be expected. The metallic path must be continuous from the ground terminal to the strike termination device. Care should be exercised in the selection of metal conductors to ensure the integrity of the lightning conductor for an extended period. A nonferrous metal such as copper or aluminum will provide, in most atmospheres, a lasting conductor free of the effects of rust or corrosion.

B.1.2 Parts of structures most likely to be struck by lightning are those that project above surrounding parts such as chimneys, ventilators, flagpoles, towers, water tanks, spires, steeples, deck railings, shafthouses, gables, skylights, dormers, ridges, and parapets. The edges and corners of the roof are the parts most likely to be struck on flat or gently sloping roofed buildings.

B.2 Lightning Protection Systems.

B.2.1 Lightning protection systems consist of the following three basic parts that provide the low impedance metal path required:

- (1) A system of strike termination devices on the roof and other elevated locations.
- (2) A system of ground terminals.
- (3) A conductor system connecting the strike termination devices to the ground terminals.

Properly located and installed, these basic components improve the likelihood that the lightning discharge will be conducted harmlessly between the strike termination devices and the ground terminals.

B.2.2 While intercepting, conducting, and dissipating the main discharge, the three basic protection system components do not ensure safety from possible secondary effects of a lightning strike. Therefore, secondary conductors are provided to interconnect metal bodies to ensure that such metal bodies are maintained at the same electrical potential so as to prevent sideflashes or sparkover. Surge suppression devices are also provided to protect power lines and associated equipment from both direct discharges and induced currents.

B.2.3 Metal parts of a structure can be used as part of the lightning protection system in some cases. For example, the structural metal framing, which has sufficient cross-sectional area to equal the conductivity of main lightning conductors, and which is electrically continuous, can be used in lieu of separate down conductors. In such cases, air terminals can be bonded to the framework at the top, and ground terminals can be provided at the bottom, as described elsewhere in this standard. Structures with 4.8 mm (3/16 in.) thick, or thicker, metal shells or skins that are electrically continuous might not require a system of air terminals and down conductors.

B.2.4 The structure should be examined, and installation of air terminals should be planned for all areas or parts likely to receive a lightning discharge. The object is to intercept the discharge immediately above the parts liable to be struck and to provide a direct path to earth, rather than to attempt to divert the discharge in a direction it would not be likely to take. The air terminals

should be placed high enough above the structure to obviate danger of fire from the arc.

B.3 Positioning of air terminals.

Positioning of air terminals depends upon the physical lightning model used to describe the behavior of lightning. The development of these models has been ongoing for two hundred and fifty years and models have a basis in physical observations of lightning. While the models tend to be simplified compared to actual details of lightning development and propagation, empirical observations over hundreds of years have proven their effectiveness.

Air terminals are intended to intercept the lightning event by providing a preferred attachment point for lightning's electrical discharge. They operate by actually providing an upward propagating leader of ionized air to intercept a downward lightning leader. Since these leaders are ionized air of opposite charge, they attract and provide the electrical channel to earth for lightning when they connect. Air terminals placed upon a structure do not substantially increase the probability of the structure being struck by lightning. If the downward progressing lightning leader is close to the structure, it will probably attach to that structure anyway. Thus, air terminals are designed to provide a preferential attachment point on structures that already provide a likely lightning attachment point. Once lightning connects to the air terminal, it is easier to control the lightning current and direct it to earth as opposed to it taking a random, uncontrolled (and usually damaging) path through the structure otherwise.

B.3.1 Physics of Lightning Attachment. The first stroke of a ground flash is normally preceded by a downward-progressing, low-current leader discharge that commences in the negatively charged region of the cloud and progresses towards the earth, depositing negative charges in the air surrounding the leader discharge channel. (Occasionally, the downward leader can be positive in charge but this does not affect its behavior in terms of attachment.) When the lower end of the downward leader is 100 – 300 m (330 – 1000 ft.) from the earth or grounded objects, upward leaders are likely to be initiated from prominent points on grounded objects, and to propagate towards the downward leader. Several upward leaders may start, but usually only one is successful in reaching the downward leader.

The high current phase (return stroke) commences at the moment the upward leader connects with the downward leader. The position in space of the lower portion of the lightning discharge channel is therefore determined by the path of the successful leader, i.e. the one that succeeded in reaching the downward leader. The primary task in protecting a structure is to ensure a high probability that the successful leader originates from the air terminals and not from a part of the structure that would be adversely affected by the lightning current that subsequently flows.

As the path of the successful leader may have a large horizontal component as well as a vertical component, an elevated air terminal will provide protection for objects spread out below it. It is therefore possible to provide protection for a large volume with correctly positioned air terminals. This is the basis for the concept of a “zone of protection” and provides the basic principle underlying lightning protection.

Therefore, the function of an air terminal in a lightning protection system (LPS) is to divert to itself the lightning discharge that might otherwise strike a vulnerable part of the object to be protected. It is generally accepted that the range over which an air terminal can intercept a lightning discharge is not constant, but increases with the severity of the discharge.

The upper outer edges and corners of buildings or structures, and especially protruding parts, are likely to have higher local electric fields than elsewhere, and are therefore likely places for the initiation of upward leaders. Consequently, the most probable strike attachment point on a building is the edge, corner, or other protruding part in the vicinity of the downward leader. Hence, if air terminals are placed at all locations where high electric fields and leader initiation are likely, there will be a high probability that the discharge will be intercepted successfully. These fields are not as strong on flat surfaces as they are on edges and corners and consequently, are less likely to be struck.

B.3.2 Overview of Methods.

A “design method” is used to identify the most suitable locations for placing strike termination devices, based on the area of protection afforded by each one. There are two categories of “placement methods” as used in NFPA 780:

- Purely geometrical constructions, such as the “Cone of Protection” or “Protection Angle” method;
- Electrogeometric models (EGM's), in which empirical relationships for striking distance and lightning peak current are invoked. The most common example is the “Rolling Sphere Method”, which is also partly a geometric construction.

B.3.2.1 Cone of Protection (“Protection Angle”) Method.

This method is based on the assumption that an air terminal or an elevated, grounded object creates an adjacent, conical space that is essentially immune to lightning. The concept of a cone of sufficient angle to define the protected zone

has its roots in the very beginning of lightning protection studies. Although Franklin recognized a limit as to the range of the air terminal in the late 1700's, the concept was first formally proposed by the French Academy of Sciences in 1823 and initially used a base of twice the height, i.e., an angle of 63°. By 1855, this angle was changed to 45° due to field reports that the method was failing. Generally, this angle was preserved in standards for more than one hundred years. In some standards today, a variable angle depending on the height of the structure is used. In addition, this protective angle may be increased when considering the placement of air terminals on the interior of large flat surfaces due to the reduced electric field strength.

A cone of protection is limited; this is articulated by the requirements in Chapter 4.

B.3.2.2 Rolling Sphere Method.

The Rolling Sphere method was incorporated into NFPA 780 in the 1980 edition. It originated from the electric power transmission industry, i.e., lightning strike attachment to phase and shield wires of lines and is based on the simple Electrogeometric Model. To apply the method, an imaginary sphere is rolled over the structure. All surface contact points are deemed to require protection, whilst the unaffected surfaces and volumes are deemed to be protected, as shown in Figure B.3.2.2.

The physical basis for the Rolling Sphere method is the Electrogeometric Model. Consider a particular peak lightning current I_p (kA) and the corresponding “striking distance” d_s (m), where $d_s = 10 I_p^{0.6}$. For a typical peak current of 10 kA, the striking distance is approximately 45 m (150 ft.), i.e., this is the distance at which a downward leader results in the initiation of an upward leader from the structure.

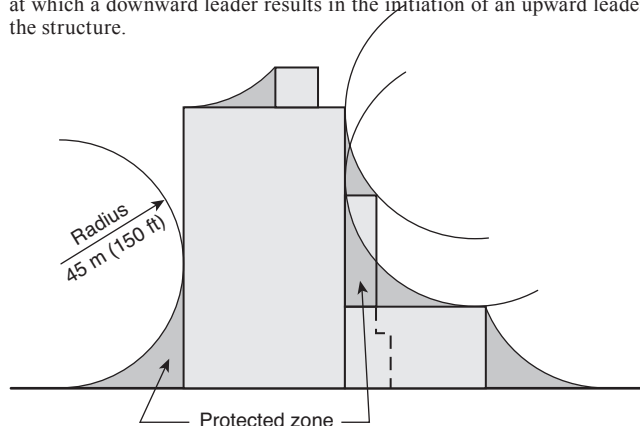

FIGURE B.3.2.2 Lightning Protection Design Using the Rolling Sphere Method

Note that a smaller striking distance (implying a lower peak current of the lightning event) results in a smaller sphere that can intrude upon the standard 45 m (150 ft.) zone of protection. Thus, more conservative design is to size the sphere using a lower lightning peak current. Lightning peak currents below 5 kA – 7 kA are not common, however; 10 kA peak current represent 91% of all lightning events.

The advantage of the Rolling Sphere Method (RSM) is that it is relatively easy to apply, even to buildings with complicated shapes. However, since it is a simplification of the physical process of lightning attachment to a structure, it has some limitations. The main limitation is that it assigns an equal leader initiation ability to all contact points on the structure, i.e., no account is taken of the influence of electric fields in initiating return streamers, so it does not distinguish between likely and unlikely lightning strike attachment points. In other words, for a given prospective peak stroke current, the striking distance d_s is a constant value. This simplification stems from its origins in the electrical power transmission industry, where there is considerable uniformity in the parameters of transmission lines (diameters, heights, etc). In reality, lightning may preferentially strike the corner of the building rather than the vertical flat surface half way down the side of the building. The same claims apply to the flat roof of a structure.

Some qualitative indication of the probability of strike attachment to any particular point can be obtained if the sphere is supposed to be rolled over the building in such a manner that its center moves at constant speed. Then the length of time that the sphere dwells on any point of the building gives a qualitative indication of the probability of that point being struck. Thus, for a simple rectangular building with a flat roof, the dwell time would be large at the corners and edges, and small at any point on the flat part of the roof, correctly indicating a higher probability of the corners or edges being struck, and a low probability that a point on the flat part of the roof will be struck.

When the RSM is applied to a building of height greater than the selected sphere radius, then the sphere touches the vertical edges on the sides of the building at all points above a height equal to the sphere radius. This indicates

the possibility of strikes to the sides of the building, and raises the question of the need for an air terminal network in these locations. Studies show that strikes to vertical edges on the sides of tall buildings do occur but are not very common. There are theoretical reasons for believing that only flashes with low I_p and consequently low d values are likely to be able to penetrate below the level of the roof of the building and strike the sides. Hence, the consequences of a strike to the sides of a building may result in damage of a minor nature. Unless there are specific reasons for side protection, as would be the case of a structure containing explosives, it is considered that the cost of side protection would not normally be justified.

B.4 Items to Consider When Planning Protection.

B.4.1 The best time to design a lightning protection system for a structure is during the structure's design phase, and the best time to install the system can be during construction. System components can be built in so as to be protected from mechanical displacement and environmental effects. In addition, aesthetic advantages may be gained by such concealment. Generally, it is less expensive to meet lightning protection requirements during construction.

B.4.2 Conductors should be installed to offer the least impedance to the passage of stroke current between the strike termination devices and earth. The most direct path, without sharp bends or narrow loops, is best. The impedance of the conductor system is practically inversely proportional to the number of widely separated paths. Accordingly, there should be at least two paths to ground and more, if practicable, from each strike termination device. The number of paths is increased and the impedance decreased by connecting the conductors to form a cage enclosing the building.

B.4.3 Properly made ground connections are essential to the effective functioning of a lightning protection system, and every effort should be made to provide ample contact with the earth. This does not necessarily mean that the resistance of the ground connection should be low, but rather that the distribution of metal in the earth or upon its surface in extreme cases should be such as to permit the dissipation of a stroke of lightning without damage.

B.4.4 Low resistance is desirable, but not essential, as may be shown by the extreme case on the one hand of a building resting on moist clay soil, and on the other by a building resting on bare solid rock. In the first case, if the soil is of normal resistivity or from 4,000 ohm-centimeters to 50,000 ohm-centimeters, the resistance of a ground connection made by extending the conductor 10 ft (3 m) into the ground will be from about 15 ohms to 200 ohms, and two such ground connections on a small rectangular building have been found by experience to be sufficient. Under these favorable conditions, providing adequate means for collecting and dissipating the energy of a flash without serious chance of damage is a simple and comparatively inexpensive matter.

B.4.5 In the second case, it would be impossible to make a ground connection in the ordinary sense of the term because most kinds of rocks are insulating, or at least of high resistivity, and in order to obtain effective grounding other more elaborate means are necessary. The most effective means would be an extensive wire network laid on the surface of the rock surrounding the building to which the down conductors could be connected. The resistance to earth at some distant point of such an arrangement would be high but at the same time the potential distribution about the building would be substantially the same, as though it were resting on conducting soil, and the resulting protective effect also would be substantially the same.

B.4.6 In general, the extent of the grounding arrangements will depend on the character of the soil, ranging from simple extension of the conductor into the ground where the soil is deep and of high conductivity to an elaborate buried network where the soil is very dry or of very poor conductivity. Where a network is required, it should be buried if there is soil enough to permit it, as this adds to its effectiveness. Its extent will be determined largely by the judgment of the person planning the installation with due regard to the following rule: The more extensive the underground metal available, the more effective the protection.

B.4.7 Where practicable, each ground terminal connection should extend or have a branch that extends below and at least 2 ft (0.6 m) away from the foundation walls of the building in order to minimize the likelihood of damage to foundation walls, footings, and stemwalls.

B.4.8 When a lightning conductor system is placed on a building, within or about which there are metal objects of considerable size within a few feet of a conductor, there will be a tendency for sparks or sideflashes to jump between the metal object and the conductor. To prevent damage, interconnecting conductors should be provided at all places where sideflashes are likely to occur.

B.4.9 Lightning currents entering protected buildings on overhead or underground power lines, or telephone conductors, or television or radio antennas are not necessarily restricted to associated wiring systems and appliances. Therefore, such systems should be equipped with appropriate protective devices and bonded to ensure a common potential.

B.4.10 Because a lightning protection system is expected to remain in working

condition for long periods with minimum attention, the mechanical construction should be strong and the materials used should offer resistance to corrosion and mechanical injury.

B.5 Inspection and Maintenance of Lightning Protection Systems.

It has been shown that in cases where damage has occurred to a protected structure, the damage was due to additions or repairs to the building or to deterioration or mechanical damage that was allowed to go undetected and unrepaired, or both. Therefore, it is recommended that an annual visual inspection be made and that the system be thoroughly inspected every five years.

B.6 Indirect Losses.

In addition to direct losses such as destruction of buildings by lightning, fire resulting from lightning, and the killing of livestock, indirect losses sometimes accompany the destruction or damage of buildings and their contents. An interruption to business or farming operations, especially at certain times of the year, may involve losses quite distinct from, and in addition to, the losses arising from the direct destruction of material property. There are cases where whole communities depend on the integrity of a single structure for their safety and comfort. For example, a community may depend on a water-pumping plant, a telephone relay station, a police station, or a fire station. A stroke of lightning to the unprotected chimney of a pumping plant might have serious consequences such as a lack of sanitary drinking water, irrigating water, or water for fire protection. Additional information on this topic is available in the documents identified in Annex N.1.2.1.

Committee Statement: The committee accepts the submitter's recommendation and provides edit to the text. The change satisfies the submitter's intent.

Number Eligible to Vote: 30

Ballot Results: Affirmative: 20 Negative: 5 Abstain: 1

Ballot Not Returned: 4 Dyl, D., Heary, W., Rapp, R., Reehl, D.

Explanation of Negative:

MELTON, JR., R.: The following comment applies to each of the above since each refers directly to the original proposal, 780-110. While the extended Annex B may(?) be "outside the scope of the NFPA document", I believe it is very important for those "users" of 780 to be able to read a technical summary of the rationale used in the preparation of the 780 standard. This would apply to both designers and installers of lightning protection systems. This serves to add both substantiation and credibility to the guidelines in 780 as opposed to stating "do it this way". Stating that there are various references that are already available as an alternative would not be a satisfactory response. I believe it is valuable to contain this information in Annex B, as proposed.

I, therefore, support the inclusion of the Annex B material as proposed in 780-110 by the Modeling Task Force and disagree with the committee's recommendation. This would also include any editorial, formatting and grammatical changes as necessary to make the document fit NFPA structure.

MORGAN, M.: See comment number 780-38.

RAKOV, V.: Annex B: I vote negative because the text is in need of additional shaping and editorial work. I also think that the text should be made more concise.

RISON, W.: Comment 780-39 should be rejected. The purpose of the comment is to provide scientific justification for the methods used for the placement of air terminals. In their recent book on the survey of the scientific literature on lightning, Mr. Rakov and Mr. Uman state:

"The process of lightning attachment to ground or to a grounded object is one of the least understood and most poorly documented processes of the cloud-to-ground lightning discharge."

I don't think it is appropriate to put into the standard an oversimplified explanation of a process which is not well understood, and which does not assist the user in the design of lightning protection systems. The standard could refer the reader to some references which would provide him/her with information on the current state of the science.

SANDERS, M.: This Comments should have been rejected for the following reasons:

1. This discussion of models has little to do with design and installation practices.
2. The proposed text is speculative and can not draw clear-cut conclusions because of lack of consensus within the scientific community on the points being offered.
3. The lightning attachment process is one of the least understood parts of the lightning discharge and it is premature to insert this text until it is better understood.
4. There is disagreement as to whether air terminals "attract" more lightning discharge, or "attracts" what is already going to happen.
5. There is lack of agreement as to when corona current flow begins.
6. There is no agreement that ionized air "moves" in response to an approaching leader as stated.
7. Other possible models are indicated that can affect the air terminal placements but can not be discussed within this proposed annex because they do not fall within the scope of NFPA 780. This does not seem reasonable to offer only those that can be discussed and exclude the other unnamed models.

Explanation of Abstention:

KAISER, B.: See My Explanation of Abstention on 780-1 (Log #5).

Comment on Affirmative:

STROTHER, L.: The term “ground terminal” should be replaced with “ground electrode” throughout the proposed Annex B.

This is necessary to be consistent with the rest of the NFPA document. Reference ROP-1.

780-40 Log #38 Final Action: Reject (Annex B)

Submitter: Mark P. Morgan, East Coast Lightning Equipment, Inc.

Comment on Proposal No: 780-110

Recommendation: The Committee’s rejection of this proposal in its entirety is correct.

Substantiation: This lengthy narrative on lightning protection modeling theory is not needed in an Installation standard. The proposed material is beyond the scope of the document. Certainly, the proposed discussion of models that have nothing to do with the design practices employed in NFPA 780 have no place in the standard and it is puzzling why they were presented for publication at all. M. Caie’s Explanation of Negative vote appears to suggest that a Task Force devoting significant time to a topic somehow obligates the Committee to endorse the Task Force’s proposals. The Task Force is to be commended for working hard, however the proposal’s rejection should stand. J. Tobias’ explanation of negative vote contains a lengthy new proposed addition to Annex B. It remains unclear what value if any this text adds to the standard. Some of the proposed text is editorializing and speculative in tone and does not seem appropriate for a standard of Installation. The value of proposed B.3.2.3 is particularly questionable. The newly proposed text in its entirety has not been adequately scrutinized for inclusion in the standard.

Committee Meeting Action: Reject

Committee Statement: The committee disagrees with the submitter. See Committee Action and Statement on 780-39 (Log #32).

Number Eligible to Vote: 30

Ballot Results: Affirmative: 21 Negative: 4 Abstain: 1

Ballot Not Returned: 4 Dyl, D., Heary, W., Rapp, R., Reehl, D.

Explanation of Negative:

MELTON, JR., R.: The following comment applies to each of the above since each refers directly to the original proposal, 780-110.

While the extended Annex B may(?) be “outside the scope of the NFPA document”, I believe it is very important for those “users” of 780 to be able to read a technical summary of the rationale used in the preparation of the 780 standard. This would apply to both designers and installers of lightning protection systems. This serves to add both substantiation and credibility to the guidelines in 780 as opposed to stating “do it this way”. Stating that there are various references that are already available as an alternative would not be a satisfactory response. I believe it is valuable to contain this information in Annex B, as proposed.

I, therefore, support the inclusion of the Annex B material as proposed in 780-110 by the Modeling Task Force and disagree with the committee’s recommendation. This would also include any editorial, formatting and grammatical changes as necessary to make the document fit NFPA structure.

PORTFLEET, T.: My Disposition is to accept not reject.

Rational: The additional information to be placed in the annex is meaningful and obviously has merit, but I do not view it as a necessary compliment to the Standard. Good information perhaps, but too much of an adder to the Standard.

RAKOV, V.: Annex B: I vote negative because I do not concur with the submitter in that “the newly proposed text in its entirety has not been adequately scrutinized for inclusion in the standard.”

SANDERS, M.: This comment should have been accepted, because the commenter’s substantiation is correct.

Explanation of Abstention:

KAISER, B.: See My Explanation of Abstention on 780-1 (Log #5).

780-41 Log #43 Final Action: Reject (Annex B)

Submitter: William Rison, New Mexico Institute of Mining & Technology

Comment on Proposal No: 780-110

Recommendation: Delete proposed new text per committee’s recommendation.

Substantiation: I agree with the Committee’s recommendation to reject the new wording. I also recommend rejection to the proposed rewording. There are two reasons for this: 1) I don’t think the extra text helps a user of the standard in the design of lightning protection systems; and 2) I don’t think that there is a consensus for a revised version. The lightning attachment process is one of the least understood parts of the lightning discharge. There is no consensus in the scientific community about the attachment process. I think several things in the new wording are incorrect (that lightning air terminals “attract” lightning; that corona current begins in response to an approaching leader; that ionized air moves in response to an approaching leader), and omits other ideas which have been proposed about the attachment process (that e.g., corona current can shield a sharp point and make it less likely to be struck). Since this should be a consensus standard, I am opposed to including material for which there is no

demonstrated scientific consensus.

Committee Meeting Action: Reject

Committee Statement: The committee disagrees with the submitter. See Committee Action and Statement on 780-39 (Log #32).

Number Eligible to Vote: 30

Ballot Results: Affirmative: 23 Negative: 2 Abstain: 1

Ballot Not Returned: 4 Dyl, D., Heary, W., Rapp, R., Reehl, D.

Explanation of Negative:

RAKOV, V.: Annex B: negative vote, because I do concur with the submitter on most of his points.

SANDERS, M.: This comment should have been accepted, because the commenter’s substantiation is correct.

Explanation of Abstention:

KAISER, B.: See My Explanation of Abstention on 780-1 (Log #5).

780-42 Log #11 Final Action: Accept (F.1)

Submitter: Mitchell Guthrie, Blanch, NC

Comment on Proposal No: 780-98a

Recommendation: In F.1, “personnel” should be changed to “people” vice “persons” as proposed in the ROP to be consistent with the use of the term “people” in the sentence immediately preceding.

Substantiation: For consistency in terminology.

Committee Meeting Action: Accept

Number Eligible to Vote: 30

Ballot Results: Affirmative: 25 Abstain: 1

Ballot Not Returned: 4 Dyl, D., Heary, W., Rapp, R., Reehl, D.

Explanation of Abstention:

KAISER, B.: See My Explanation of Abstention on 780-1 (Log #5).

780-43 Log #29 Final Action: Accept in Principle (L.2)

Submitter: Mitchell Guthrie, Blanch, NC

Comment on Proposal No: 780-120

Recommendation: Reject ROP 780-120 and return to the existing map.

Substantiation: This map is better in that it contains a larger sample size but the shading resolution is not adequate to make it practical to use. The previous map using contours is a better format for a black and white medium.

Committee Meeting Action: Accept in Principle

Retain Figure L.2 1989-1998 Average U.S. Lightning Flash Density Flashes per Square Kilometer per Year. (Courtesy Global Atmospheric, Inc.)
Change title to read as follows:

FIGURE L.2(a) 1989-1998 Average U.S. Lightning Flash Density Flashes per Square Kilometer per Year. (Courtesy Global Atmospheric, Inc.)

Insert new Figure L.2(b)

See Figure L.2(b) on the next page.

New Figure L.2(b) to read as follows:

FIGURE L.2(b) 1990-2004 Average U.S. Lightning Flash Density Flashes per Square Kilometer per Year. (Courtesy Vaisala Inc.)

Change L.2 to read as follows:

L.2 Lightning Flash Density (N_g).

The yearly number of flashes to ground per square kilometer, lightning flash density, is found in Figures L.2(a) or L.2(b).

Committee Statement: The committee agrees that the map submitted in the ROP is not easily readable as the shading resolution is not adequate. The committee chooses to retain the existing contour map and also include a new map.

The change satisfies the submitter’s intent.

Number Eligible to Vote: 30

Ballot Results: Affirmative: 24 Negative: 1 Abstain: 1

Ballot Not Returned: 4 Dyl, D., Heary, W., Rapp, R., Reehl, D.

Explanation of Negative:

RAKOV, V.: Negative vote, because in my opinion, two ground flash density maps in the same standard will cause confusion.

Explanation of Abstention:

KAISER, B.: See My Explanation of Abstention on 780-1 (Log #5).

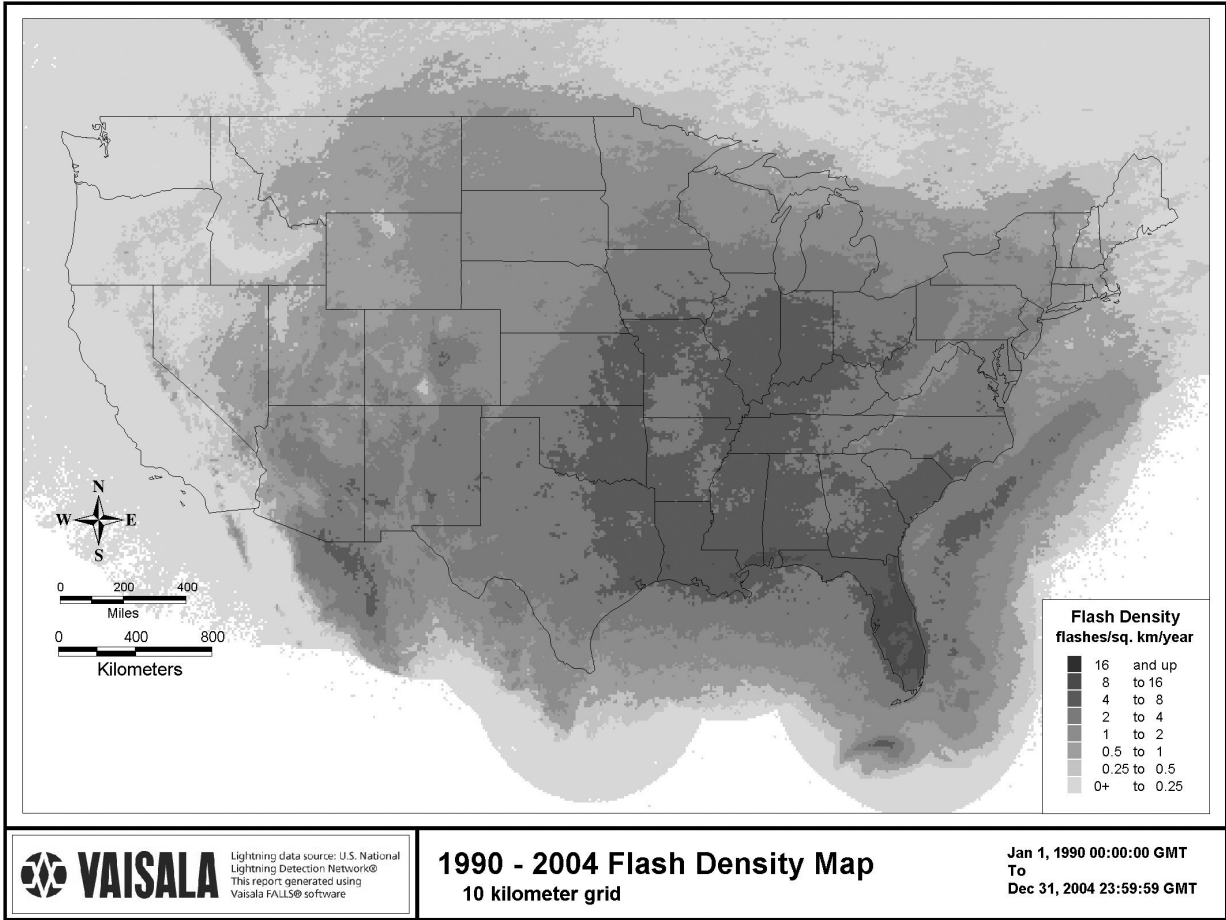

All content copyright 1991-2003 Vaisala Inc. Any redistribution or reproduction without proper consent is strictly prohibited.

Figure L.2(b)

**FORM FOR FILING NOTICE OF INTENT TO MAKE A MOTION (NITMAM)
 AT AN ASSOCIATION TECHNICAL MEETING
 2007 ANNUAL REVISION CYCLE
 FINAL DATE FOR RECEIPT OF NITMAM: 5:00 pm EST, April 6, 2007**

If you have questions about filling out or filing the NITMAM, please contact the
 Codes and Standards Administration at 617-984-7249

For further information on the Codes- and Standards-Making Process, see the NFPA
 website (www.nfpa.org)

FOR OFFICE USE ONLY

Log #: _____

Date Rec'd: _____

Date _____ Name _____ Tel. No. _____

Company or Affiliation _____ Email Address _____

Street Address _____ City _____ State _____ Zip _____

1. (a) NFPA Document (include Number and Title) _____

(b) Proposal or Comment Number _____

(c) Section/Paragraph _____

2. Motion to be made. Please check one: (See also 4-6 of the Regulations Governing Committee Projects)

(a) Proposal

_____ (1) Accept. _____ (2) Accept an Identifiable Part.*

_____ (3) Accept as modified by the TC. _____ (4) Accept an Identifiable Part as modified by TC.*

(b) Comment

_____ (1) Accept. _____ (2) Accept an Identifiable Part.* _____ (3) Accept as modified by the TC.

_____ (4) Accept an Identifiable Part as modified by TC.* _____ (5) Reject _____ (6) Reject an Identifiable Part.*

(c) Return Technical Committee Report for Further Study

_____ (1) Return entire Report. _____ (2) Return a portion of a Report in the form of a proposal and related comment(s).

_____ (3) Return a portion of a Report in the form of identifiable part(s) of a proposal and related comments (s). (Identify the specific portion of the proposal and the related comments below)*

* Clearly identify the Identifiable Part(s) indicated above (use separate sheet if required).

3. I am entitled to make this motion in accordance with 4.6.8 of the Regulations Governing Committee Projects, as follows: (check (a), (b), or (c).

(a) _____ This motion may be made by the original submitter or their designated representative, and I am the (if you check (a) indicate one of the following):

- ___ I am the Original submitter, or
- ___ I am the submitter's designated representative (attach written authorization signed by the original submitter), or
- ___ I am an Organizational Member delegate permitted to represent the submitter on behalf of the Organization Member in accordance with 4-6.5 (c).

(b) _____ This motion may be made by a Technical Committee Member and I am a Member of the responsible Technical Committee.

(c) _____ This motion may be made by anyone.

(Form continued on next page)

Sequence of Events Leading to Issuance of an NFPA Committee Document

Step 1 Call for Proposals

▼ Proposed new Document or new edition of an existing Document is entered into one of two yearly revision cycles, and a Call for Proposals is published.

Step 2 Report on Proposals (ROP)

▼ Committee meets to act on Proposals, to develop its own Proposals, and to prepare its Report.

▼ Committee votes by written ballot on Proposals. If two-thirds approve, Report goes forward. Lacking two-thirds approval, Report returns to Committee.

▼ Report on Proposals (ROP) is published for public review and comment.

Step 3 Report on Comments (ROC)

▼ Committee meets to act on Public Comments to develop its own Comments, and to prepare its report.

▼ Committee votes by written ballot on Comments. If two-thirds approve, Reports goes forward. Lacking two-thirds approval, Report returns to Committee.

▼ Report on Comments (ROC) is published for public review.

Step 4 Technical Report Session

▼ “*Notices of intent to make a motion*” are filed, are reviewed, and valid motions are certified for presentation at the Technical Report Session. (“Consent Documents” that have no certified motions bypass the Technical Report Session and proceed to the Standards Council for issuance.)

▼ NFPA membership meets each June at the Annual Meeting Technical Report Session and acts on Technical Committee Reports (ROP and ROC) for Documents with “certified amending motions.”

▼ Committee(s) vote on any amendments to Report approved at NFPA Annual Membership Meeting.

Step 5 Standards Council Issuance

▼ Notification of intent to file an appeal to the Standards Council on Association action must be filed within 20 days of the NFPA Annual Membership Meeting.

▼ Standards Council decides, based on all evidence, whether or not to issue Document or to take other action, including hearing any appeals.

The Technical Report Session of the NFPA Annual Meeting

The process of public input and review does not end with the publication of the ROP and ROC. Following the completion of the Proposal and Comment periods, there is yet a further opportunity for debate and discussion through the Technical Report Sessions that take place at the NFPA Annual Meeting.

The Technical Report Session provides an opportunity for the final Technical Committee Report (i.e., the ROP and ROC) on each proposed new or revised code or standard to be presented to the NFPA membership for the debate and consideration of motions to amend the Report. The specific rules for the types of motions that can be made and who can make them are set forth in NFPA's rules which should always be consulted by those wishing to bring an issue before the membership at a Technical Report Session. The following presents some of the main features of how a Report is handled.

What Amending Motions are Allowed. The Technical Committee Reports contain many Proposals and Comments that the Technical Committee has rejected or revised in whole or in part. Actions of the Technical Committee published in the ROP may also eventually be rejected or revised by the Technical Committee during the development of its ROC. The motions allowed by NFPA rules provide the opportunity to propose amendments to the text of a proposed code or standard based on these published Proposals, Comments and Committee actions. Thus, the list of allowable motions include motions to accept Proposals and Comments in whole or in part as submitted or as modified by a Technical Committee action. Motions are also available to reject an accepted Comment in whole or part. In addition, Motions can be made to return an entire Technical Committee Report or a portion of the Report to the Technical Committee for further study.

The NFPA Annual Meeting, also known as the World Safety Conference and Exposition®, takes place in June of each year. A second Fall membership meeting was discontinued in 2004, so the NFPA Technical Report Session now runs once each year at the Annual Meeting in June.

Who Can Make Amending Motions. Those authorized to make these motions is also regulated by NFPA rules. In many cases, the maker of the motion is limited by NFPA rules to the original submitter of the Proposal or Comment or his or her duly authorized representative. In other cases, such as a Motion to Reject an accepted Comment, or to Return a Technical Committee Report or a portion of a Technical Committee Report for Further Study, anyone can make these motions. For a complete explanation, NFPA rules should be consulted.

The filing of a Notice of Intent to Make a Motion. Before making an allowable motion at a Technical Report Session, the intended maker of the motion must file, in advance of the session, and within the published deadline, a Notice of Intent to Make a Motion. A Motions Committee appointed by the Standards Council then reviews all notices and certifies all amending motions that are proper. The Motions Committee can also, in consultation with the makers of the motions, clarify the intent of the motions and, in certain circumstances, combine motions that are dependent on each other together so that they can be made in one single motion. A Motions Committee report is then made available in advance of the meeting listing all certified motions. Only these Certified Amending Motions, together with certain allowable Follow-Up Motions (that is, motions that have become necessary as a result of previous successful amending motions) will be allowed at the Technical Report Session.

Consent Documents. Often there are codes and standards up for consideration by the membership that will be non-controversial and no proper Notices of Intent to Make a Motion will be filed. These "Consent Documents" will bypass the Technical Report Session and head straight to the Standards Council for issuance. The remaining Documents are then forwarded to the Technical Report Session for consideration of the NFPA membership.

Important Note: *The filing of a Notice of Intent to Make a Motion is a new requirement that takes effect beginning with those Documents scheduled for the Fall 2005 revision cycle that reports to the June 2006 Annual Meeting Technical Report Session. The filing of a Notice of Intent to Make a Motion will not, therefore, be required in order to make a motion at the June 2005 Annual Meeting Technical Report Session. For updates on the transition to the new Notice requirement and related new rules effective for the Fall 2005 revision cycle and the June 2006 Annual Meeting, check the NFPA website.*

Action on Motions at the Technical Report Session. In order to actually make a Certified Amending Motion at the Technical Report Session, the maker of the motion must sign in at least an hour before the session begins. In this way a final list of motions can be set in advance of the session. At the session, each proposed Document up for consideration is presented by a motion to adopt the Technical Committee Report on the Document. Following each such motion, the presiding officer in charge of the session opens the floor to motions on the Document from the final list of Certified Amending Motions followed by any permissible Follow-Up Motions. Debate and voting on each motion proceeds in accordance with NFPA rules. NFPA membership is not required in order to make or speak to a motion, but voting is limited to NFPA members who have joined at least 180 days prior to the session and have registered for the meeting. At the close of debate on each motion, voting takes place, and the motion requires a majority vote to carry. In order to amend a Technical Committee Report, successful amending motions must be confirmed by the responsible Technical Committee, which conducts a written ballot on all successful amending motions following the meeting and prior to the Document being forwarded to the Standards Council for issuance.

Standards Council Issuance

One of the primary responsibilities of the NFPA Standards Council, as the overseer of the NFPA codes and standards development process, is to act as the official issuer of all NFPA codes and standards. When it convenes to issue NFPA documents it also hears any appeals related to the Document. Appeals are an important part of assuring that all NFPA rules have been followed and that due process and fairness have been upheld throughout the codes and standards development process. The Council considers appeals both in writing and through the conduct of hearings at which all interested parties can participate. It decides appeals based on the entire record of the process as well as all submissions on the appeal. After deciding all appeals related to a Document before it, the Council, if appropriate, proceeds to issue the Document as an official NFPA code or standard. Subject only to limited review by the NFPA Board of Directors, the Decision of the Standards Council is final, and the new NFPA code or standard becomes effective twenty days after Standards Council issuance. The illustration on page 9 provides an overview of the entire process, which takes approximately two full years to complete.