

DELETED**First Revision No. 43-NFPA 24-2019 [Global Input]**

In the Table of Contents and throughout Annex C and D, revise all references (10 locations) from "fire flow testing" to "water flow testing" and "fire flow test" to "water flow test".

Submitter Information Verification**Committee:****Submittal Date:** Wed Aug 28 11:44:58 EDT 2019**Committee Statement**

Committee Statement: NFPA 291 has been revised to address water flow testing and is not limited to fire flow testing.

Response Message: FR-43-NFPA 24-2019



First Revision No. 2-NFPA 24-2019 [Section No. 1.1]

1.1 Scope.

1.1.1

This standard shall ~~cover~~ provide the minimum requirements for the installation of private fire service mains and their appurtenances, which include supplying the following:

- (1) Automatic sprinkler systems
- (2) Open sprinkler systems
- (3) Water spray fixed systems
- (4) Foam systems
- (5) Private hydrants
- (6) Monitor nozzles or standpipe systems with reference to water supplies
- (7) Hose houses

1.1.2

This standard shall apply to combined service mains intended to carry water for fire service and other uses.

1.1.3

This standard shall not apply to the following situations:

- (1) Mains under the control of a water utility
- (2) Mains providing fire protection and/or domestic water that are privately owned but are operated as a water utility
- (3)* Dry fire hydrants utilized for drafting or mains connected to dry fire hydrants utilized for drafting

A.1.1.3(3)

The installation of dry fire hydrants is covered in NFPA 1142 .

1.1.4

This standard shall not apply to underground mains serving sprinkler systems designed and installed in accordance with NFPA 13R that are less than 4 in. (100 mm) in nominal diameter.

1.1.5

This standard shall not apply to underground mains serving sprinkler systems designed and installed in accordance with NFPA 13D.

Submitter Information Verification

Committee: AUT-PRI

Submission Date: Fri Aug 16 08:13:37 EDT 2019

Committee Statement

Committee Statement: This proposal offered to clarify that the text in NFPA 24 does delve into the subject of "fire flow". The fire flow required for actual fire fighting purposes is the subject matter for building and fire codes. It is not within the scope of NFPA 24, which is primarily an installation standard.

When NFPA 24 currently speaks to "fire flow testing" the subject matter is really just providing a method for conducting water flow tests for fire protection purposes, be it to determine the available

water supply for things such as a sprinkler system design or a NFPA 25 requirement, or to actually confirm the water supply relative to a facility's fire flow requirement.

Response Message: FR-2-NFPA 24-2019 is based on PI 37 with the exception of revising committee scope. PI 42 is part of the FR PI 2 is also part of the FR 2.

[Public Input No. 2-NFPA 24-2018 \[Section No. 1.1.3\]](#)

[Public Input No. 42-NFPA 24-2019 \[Section No. 1.1.1\]](#)

[Public Input No. 37-NFPA 24-2019 \[Section No. 1.1\]](#)



First Revision No. 3-NFPA 24-2019 [Section No. 1.5]

1.5 Units.

1.5.1

Metric units of measurement in this standard shall be in accordance with the modernized metric system known as the International System of Units (SI). Liter and bar units are not part of, but are recognized by, SI and are used commonly in international fire protection. These units are shown in Table 1.5.1 with conversion factors.

Table 1.5.1 Conversion Table for SI Units

Name of Unit	Unit Symbol	Conversion Factor
Liter	L	1 gal = 3.785 L
Liter per minute per square meter	(L/min)/m ²	1 gpm/ft ² = (40.746 L/min)/m ²
Cubic decimeter	dm ³	1 gal = 3.785 dm ³
Pascal	Pa	1 psi = 6894.757 Pa
Bar	bar	1 psi = 0.0689 bar
Bar	bar	1 bar = 10 ⁵ Pa

Note: For additional conversions and information, see ASTM SI10, *Standard for Use of the International System of Units (SI): The Modern Metric System*.

1.5.1.1

Two units (liter and bar) are outside of but recognized by SI, and are commonly used in international fire protection.

1.5.1.2

These units with conversion factors shall be used as listed in Table 1.5.1.2.

Table 1.5.1.2 Conversion Table for SI Units

Quantity	Name of Unit	Unit Symbol	Conversion Factor
Length	Meter	m	1 ft = 0.3048 m
Area	Square meter	m ²	1 ft ² = 0.092903 m ²
Volume	Cubic meter	m ³	1 ft ³ = 0.028317 m ³
Fluid capacity	Liter	L	1 gal = 3.785 L
Flow	Liter per minute	L/min	1 gpm = 3.785 L/min
Pressure	Bar	bar	1 psi = 0.0689 bar
	Kilopascal	kPa	1 psi = 6.894757 kPa
	Newton per square meter	N/m ²	1 lbf/ft ² = 47.8800 N/m ²
Temperature	Degrees Celcius	°C	1°F = $\frac{9}{5} \times C^{\circ} + 32$
Velocity	Meter per second	m/s	1 fps = 0.3048 m/s
Force	Newton	N	1 lbf = 4.448822 N
Stress	Kilonewton per square meter	kN/m ²	1 lbf/ft ² = 0.047880 kN/m ²
	Megapascal	MPa	1 lbf/in. ² = 0.006895 MPa

Note: For additional conversions and information, see ASTM SI10, *IEEE/ASTM SI 10 American National Standard for Metric Practice*.

1.5.2

If a value for a measurement given in this standard is followed by an equivalent value in other units, the first stated is to be regarded as the requirement. A given equivalent value might be approximate.

1.5.3*

It shall be acceptable to use the exact conversion or the conversions stated in the standard, even though they might not be exact.

A.1.5.3

Some dimensions used in this standard are exact and some are not. Nominal dimensions are often used, such as the dimensions used for pipe sizes. The metric equivalent shown in this standard might not be an exact conversion to the SI unit, but the nominal metric equivalent is typically used, or a reasonably equivalent value or approximate conversion is used.

1.5.3

~~SI units have been converted by multiplying the quantity by the conversion factor and then rounding the result to the appropriate number of significant digits.~~

Submitter Information Verification

Committee: AUT-PRI

Submittal Date: Fri Aug 16 08:15:12 EDT 2019

Committee Statement

Committee Statement: This proposal is offered to better follow the Manual of Style and to provide the same information on metric conversions as is found in NFPA 13-2019.

The current Table 1.5.1 is of little value to users of NFPA 24, because some of the units such as those for "cubic decimeters" and "liter per minute per square meter" are not used in the standard and units such as the "Pascal" are seldom used, in lieu of larger units such as the "bar" or the "kilopascal". The proposed table provides conversion factors for units which are actually used throughout the document.

Response Message: FR-3-NFPA 24-2019

[Public Input No. 10-NFPA 24-2019 \[Section No. 1.5\]](#)



First Revision No. 4-NFPA 24-2019 [Section No. 2.3]

2.3 Other Publications.

2.3.1 ASME Publications.

American Society of Mechanical Engineers, Two Park Avenue, New York, NY 10016-5990.

ASME B1.20.1, *Pipe Threads, General Purpose (Inch)*, 2013.

ASME B16.1, *Gray Iron Pipe Flanges and Flanged Fittings, Classes 12 25, 125, and 250*, 2015.

ASME B16.3, *Malleable Iron Threaded Fittings, Classes 150 and 300*, 2014 2016 .

ASME B16.4, *Gray Iron Threaded Fittings, Classes 125 and 250*, 2014 2016 .

ASME B16.15, *Cast Copper Alloy Threaded Fittings, Classes 125 and 250* , 2018.

ASME B16.18, *Cast Copper Alloy Solder Joint Pressure Fittings* , 2018.

ASME B16.22, *Wrought Copper and Copper Alloy Solder Joint Pressure Fittings* , 2018.

2.3.2 ASTM Publications.

ASTM International, 100 Barr Harbor Drive, P.O. Box C700, West Conshohocken, PA 19428-2959.

ASTM A53/A53M, *Standard Specification for Pipe, Steel, Black and Hot-Dipped, Zinc-Coated, Welded and Seamless*, 2012 2018 .

ASTM A135/A135M, *Standard Specification for Electric-Resistance-Welded Steel Pipe*, 2009, (reapproved 2014) .

ASTM A312/312M, *Standard Specification for Seamless, Welded, and Heavily Cold Worked Austenitic Stainless Steel Pipes*, 2017.

ASTM A403/A403M, *Specification for Wrought Austenitic Stainless Steel Pipe Fittings* , 2018a.

ASTM A795/A795M, *Standard Specification for Black and Hot-Dipped Zinc-Coated (Galvanized) Welded and Seamless Steel Pipe for Fire Protection Use*, 2013.

ASTM B43, *Specification for Seamless Red Brass Pipe, Standard Sizes*, 2015.

ASTM B75/B75M, *Specification for Seamless Copper Tube*, 2011.

ASTM B88, *Specification for Seamless Copper Water Tube*, 2014 2018 .

ASTM B251/B251M , *Requirements for Wrought Seamless Copper and Copper-Alloy Tube*, 2010 2017 .

ASTM SI10, *IEEE/ASTM SI 10 American National Standard for Metric Practice* , 2016.

~~ASTM C136/136M, *Standard Test Method for Sieve Analysis of Fine and Coarse Aggregates* , 2014.~~

~~ASTM D2487, *Standard Practice for Classification of Soils for Engineering Purposes (Unified Soil Classification System)* , 2011.~~

~~ASTM SI10, *Standard for Use of the International System of Units (SI): The Modern Metric System* , 2010.~~

2.3.3 AWWA Publications.

American Water Works Association, 6666 West Quincy Avenue, Denver, CO 80235.

AWWA C104/A21.4, *Cement-Mortar Lining for Ductile-Iron Pipe and Fittings*, 2014 [2016](#) .

AWWA C105/A21.5, *Polyethylene Encasement for Ductile-Iron Pipe Systems*, 2010.

AWWA C110/A21.10, *Ductile-Iron and Gray-Iron Fittings*, 2012.

AWWA C111/A21.11, *Rubber-Gasket Joints for Ductile-Iron Pressure Pipe and Fittings*, 2012 [2017](#) .

AWWA C115/A21.15, *Flanged Ductile-Iron Pipe with Ductile-Iron or Gray-Iron Threaded Flanges*, 2011.

AWWA C150/A21.50, *Thickness Design of Ductile-Iron Pipe*, 2014.

AWWA C151/A21.51, *Ductile-Iron Pipe, Centrifugally Cast*, 2009 [2017](#), [errata 2018](#) .

AWWA C153/A21.53, *Ductile-Iron Compact Fittings*, 2011.

AWWA C300, *Reinforced Concrete Pressure Pipe, Steel-Cylinder Type*, 2011 [2016](#) .

AWWA C301, *Prestressed Concrete Pressure Pipe, Steel-Cylinder Type*, 2014.

AWWA C302, *Reinforced Concrete Pressure Pipe, Noncylinder Type*, 2011 [2016](#) .

AWWA C303, *Reinforced Concrete Pressure Pipe, Bar-Wrapped, Steel-Cylinder Type*, 2008 [2017](#) .

AWWA C600, *Installation of Ductile Iron Water Mains and Their Appurtenances*, 2010 [2017](#) .

AWWA C602, *Cement-Mortar Lining of Water Pipe Lines in Place, 4 in. (100 mm) and Larger*, 2011 [2017](#) .

AWWA C900, *Polyvinyl Chloride (PVC) Pressure Pipe and Fabricated Fittings, 4 in. Through 12 in. Through 60 in. (100 mm Through 300 mm), for Water Transmission and Distribution Through 1,500 mm* , 2007, [Errata](#), 2008 [2016](#) .

~~AWWA C905, *Polyvinyl Chloride (PVC) Pressure Pipe and Fabricated Fittings, 14 in. Through 48 in. (350 mm Through 1200 mm), for Water Transmission and Distribution* , 2010, [Erratum](#), 2013.~~

AWWA C906, *Polyethylene (PE) Pressure Pipe and Fittings, 4 in. (100 mm) Through 63 in. (1575 mm 1650 mm) for Waterworks*, 2015.

AWWA C909, *Molecularly Oriented Polyvinyl Chloride (PVCO) Pressure Pipe, 4 in. Through 24 in. (100 mm) Through 600 mm), for Water, Wastewater, and Reclaimed Water Service and Larger* , 2009 [2016](#) .

AWWA M9, *Concrete Pressure Piping* , 2008, [errata 2013](#).

AWWA M23, *PVC Pipe — Design and Installation*, 2002.

AWWA M55, *PE Pipe — Design and Installation*, 2006.

2.3.4 Other Publications.

Merriam-Webster's Collegiate Dictionary, 11th edition, Merriam-Webster, Inc., Springfield, MA, 2003.

Submitter Information Verification

Committee: AUT-PRI

Submission Date: Fri Aug 16 08:19:15 EDT 2019

Committee Statement

Committee Statement: Referenced current national consensus standard editions.

Response Message: FR-4-NFPA 24-2019

Public Input No. 5-NFPA 24-2018 [Section No. 2.3]



First Revision No. 5-NFPA 24-2019 [New Section after 3.3.15]

3.3.16 System Working Pressure.

The maximum anticipated static (nonflowing) or flowing pressure applied to fire protection system components exclusive of surge pressures and exclusive of pressure from the fire department connection.

Submitter Information Verification

Committee: AUT-PRI

Submittal Date: Fri Aug 16 08:19:36 EDT 2019

Committee Statement

Committee Statement: A definition of system working pressure is needed in this document.

Response Message: FR-5-NFPA 24-2019

Public Input No. 55-NFPA 24-2019 [New Section after 3.3.15]



First Revision No. 6-NFPA 24-2019 [Section No. 5.2]

5.2 Size of Fire Mains.

5.2.1 Private Fire Service Mains.

5.2.1.1

Hydraulic calculations shall show that the main is able to supply the total demand at the appropriate required design pressure.

5.2.1.2

For mains that supply fire hydrants, pipe size shall not be less than 6 in. (150 mm) nominal size.

5.2.2 Mains Not Supplying Hydrants.

For mains that do not supply hydrants, pipe sizes less than 6 in. (150 mm) nominal size shall be permitted to be used subject to the following restrictions:

- (1) The main shall supply only the following types of systems:
 - (a) Automatic sprinkler systems
 - (b) Open sprinkler systems
 - (c) Water spray fixed systems
 - (d) Foam systems
 - (e) Standpipe systems
- (2) Hydraulic calculations shall show that the main is able to supply the total demand at the appropriate required design pressure.
- (3) Systems that are not hydraulically calculated shall have a main at least as large as the riser.

Submitter Information Verification

Committee: AUT-PRI

Submittal Date: Fri Aug 16 08:24:11 EDT 2019

Committee Statement

Committee Statement: The current language in section 5.2.1 would allow mains supplying fire hydrants to be less than 6" if the hydraulic calculations would support such a design. Based on the language on 5.2.2, AWWA recommendations and best practices for the design of water distribution lines supplying fire hydrants, the appropriate minimum size for mains supplying fire hydrants is no less than 6". This PI clarifies that the hydraulic calculations much occur but that those calculations cannot be utilized to justify installing mains of less than 6" supplying fire hydrants.

Response Message: FR-6-NFPA 24-2019 PI 11 is also part of this FR PI 12 is also part of this FR

[Public Input No. 44-NFPA 24-2019 \[Section No. 5.2\]](#)

[Public Input No. 11-NFPA 24-2019 \[Section No. 5.2.1\]](#)

[Public Input No. 12-NFPA 24-2019 \[Section No. 5.2.2\]](#)



First Revision No. 7-NFPA 24-2019 [Section No. 5.8]

5.8 Penstocks, Rivers, Lakes, or Reservoirs.

Water supply connections from penstocks, rivers, lakes, or reservoirs shall be designed to avoid prevent the introduction of mud and sediment and shall be provided with approved, double, removable screens or approved strainers installed in an approved manner.

5.8.1*

When water supply connections are from penstocks, rivers, lakes, or reservoirs, measures shall be taken to prevent freezing.

A.5.8.1

Intakes installed in surface water such as springs, creeks, lakes, and man-made reservoirs should be designed to protect against ice development. Still water (nonflowing) will freeze at the air/water interface and form sheet ice, reducing the total volume of available water for fire protection needs. Turbulent or flowing water can still have icing issues called frazil ice.

The density of water is at its highest at 39°F (4°C) causing any ice formations to float and not pose any potential danger to intakes below the surface. While ice can be present on the surface, warmer water can settle to the bottom of the reservoir. Circulating this warmer water can be another method of freeze protection. Further, submerged aeration systems whether by solar, wind, or commercial power can create a mixing effect and prevent freezing.

The effects of cold temperatures can be estimated by obtaining the freezing index of the local area. The freezing index can be used to estimate the thickness of ice using the following formula:

$$\text{Maximum ice thickness (in.)} = 1.42 \sqrt{\text{freezing index (°C)}} \quad \text{[A.5.8.1]}$$

For example a freezing index of 68 will result in: maximum ice thickness = 1.42√68 = 11.7 in.

Therefore, an intake drawing water from a pond or lake in this locale should be deeper than 12 in. to remain free of any ice buildup during winter months.

For more information see the fact sheet "Winter Considerations, Ice Formation, Freezing Index, and Frost Penetration, Ministry of Agriculture and Lands, British Columbia."

Submitter Information Verification

Committee: AUT-PRI

Submission Date: Fri Aug 16 08:26:43 EDT 2019

Committee Statement

Committee Statement: This proposal regarding Section 5.8 is to eliminate the word "avoid", which is not enforceable.

The new Section 5.8.1 and A.5.8.1 is proposed to alert users of the standard that as well as sediment and mud, when the water supply is from penstocks, rivers, lakes, or reservoirs, freezing considerations also have to be examined.

The text for the proposed 5.8.1 was adapted from Section 4.16.6.2.2 of NFPA 20-2019.

The text for the proposed A.5.8.1 was adapted from the Fact Sheet – Winter Considerations, Ice Formation, Freezing Index, and Frost Penetration, Ministry of Agriculture and Lands, British Columbia.

Response Message: FR-7-NFPA 24-2019

[Public Input No. 13-NFPA 24-2019 \[Section No. 5.8\]](#)



First Revision No. 8-NFPA 24-2019 [Section No. 5.9.1.3]

5.9.1.4

Fire department connections shall be equipped with approved plugs or caps that are secured and arranged for easy- removal by fire departments.

Submitter Information Verification

Committee: AUT-PRI

Submittal Date: Fri Aug 16 08:30:42 EDT 2019

Committee Statement

Committee Statement: This proposal is to eliminate the word “easy”, which is not enforceable. Additionally, if the caps are easily removed, they would not necessarily be secure.

The new Annex text is offered to better clarify why the caps/plugs must be “secure” and how removal by the F.D. is to be accomplished.

Response Message: FR-8-NFPA 24-2019 Proposed annex material was not accepted.

[Public Input No. 14-NFPA 24-2019 \[Section No. 5.9.1.3\]](#)



First Revision No. 9-NFPA 24-2019 [New Section after 5.9.1.4]

5.9.1.2

A single fire department connection shall be permitted to supply multiple buildings where acceptable to the AHJ.

Submitter Information Verification

Committee: AUT-PRI

Submittal Date: Fri Aug 16 08:32:32 EDT 2019

Committee Statement

Committee Statement: There are some situations where it is more desirable for the responding fire department to connect to a single FDC to pressurize multiple buildings. This could be a site where vehicle access may be limited. It could also be on a site with multiple buildings supplied by a single fire pump.

Response Message: FR-9-NFPA 24-2019 Insert as a new 5.9.1.2 and renumber 5.9.1.2 and subsequent sections.

Public Input No. 54-NFPA 24-2019 [New Section after 5.9.1.4]



First Revision No. 10-NFPA 24-2019 [Section No. 5.9.5.1]

5.9.5.1*

Remote fire department connections shall be located ~~at the nearest point of~~ adjacent to a street or an access route to permit fire department apparatus accessibility, or at a location approved by the AHJ.

Submitter Information Verification

Committee: AUT-PRI

Submittal Date: Fri Aug 16 08:43:24 EDT 2019

Committee Statement

Committee Statement: This proposal is to eliminate the word "nearest", since it may not be always practical or desirable to locate an FDC at the nearest point, depending on the landscaping, etc.

Response Message: FR-10-NFPA 24-2019

[Public Input No. 15-NFPA 24-2019 \[Section No. 5.9.5.1\]](#)



First Revision No. 11-NFPA 24-2019 [Section No. 6.2.7]

6.2.7

Where a pump is located in a combustible pump house or exposed to danger from fire or falling walls, or where a tank discharges into a private fire service main fed by another supply, one of the following requirements shall be met:

- (1)* The check valve in the connection shall be located in a pit.
- (2) The control valve shall be of the post indicator type and located ~~a safe distance outside buildings~~ not less than 40 ft (12 m) from outside buildings .
- (3) For buildings less than 40 ft (12 m) in height, ~~a post indicator valve shall be permitted to be installed closer than 40 ft (12 m) but at least as far from the building as the height of the wall facing the post indicator valve.~~

Submitter Information Verification

Committee: AUT-PRI

Submittal Date: Fri Aug 16 08:44:25 EDT 2019

Committee Statement

Committee Statement: This proposal is to eliminate the words "safe distance", which is not enforceable. The new text is provided to specify the where the valve needs to be located.

Response Message: FR-11-NFPA 24-2019

[Public Input No. 16-NFPA 24-2019 \[Section No. 6.2.7\]](#)



First Revision No. 12-NFPA 24-2019 [Sections 6.4.1, 6.4.2, 6.4.3]

6.4.1

Valve pits located ~~at or near the base of the riser of~~ on the discharge pipe of an elevated tank shall be designed in accordance with ~~Chapter 14 of~~ NFPA 22.

6.4.2

Where used, valve pits shall be of ~~adequate size and accessible~~ a size to permit access for inspection, operation, testing, maintenance, and removal of equipment contained therein.

6.4.3

Valve pits shall be constructed and arranged ~~properly~~ to protect the installed equipment from movement of earth, freezing, and accumulation of water.

6.4.3.1

Depending on soil conditions and the size of the pit, valve pits shall be permitted to be constructed of any of the following materials:

- (1) Poured-in-place or precast concrete, with or without reinforcement
- (2) Brick
- (3) Other approved materials

6.4.3.2

Where the water table is low and the soil is porous, crushed stone or gravel shall be permitted to be used for the floor of the pit.

Submitter Information Verification

Committee: AUT-PRI

Submission Date: Fri Aug 16 08:46:22 EDT 2019

Committee Statement

Committee Statement: This proposal is to revise 6.4.1, 6.4.2 and 6.4.3 to eliminate the terms “or near”, “adequate” and “appropriate”, which are not enforceable.

The new text is for 6.4.1 is proposed, to better specify when the valve pit must be installed per NFPA 22 and the reference to Chapter 14 of NFPA 22 was deleted, because with the revisions to that standard, the requirements for pits and valve houses is no longer in that chapter.

Response Message: FR-12-NFPA 24-2019

[Public Input No. 17-NFPA 24-2019 \[Sections 6.4.1, 6.4.2, 6.4.3\]](#)



First Revision No. 13-NFPA 24-2019 [Section No. 6.6.1]

6.6.1*

Sectional valves shall be provided at appropriate locations within piping sections such that the number of fire protection connections between sectional valves does not exceed six.

Submitter Information Verification

Committee: AUT-PRI

Submittal Date: Fri Aug 16 08:47:02 EDT 2019

Committee Statement

Committee Statement: This proposal is to eliminate the word "appropriate", which is not enforceable.

Response Message: FR-13-NFPA 24-2019 PI 53 is also part of the FR.

[Public Input No. 18-NFPA 24-2019 \[Section No. 6.6.1\]](#)

[Public Input No. 53-NFPA 24-2019 \[Section No. 6.6.1\]](#)



First Revision No. 14-NFPA 24-2019 [Section No. 7.1.1.3]

7.1.1.3*

The number, size, and arrangement of outlets; the size of the main valve opening; and the size of the barrel shall be suitable determined by the required flow and pressure for the protection to be provided and shall be approved by the AHJ.

Submitter Information Verification

Committee: AUT-PRI

Submittal Date: Fri Aug 16 08:56:21 EDT 2019

Committee Statement

Committee Statement: This proposal is to eliminate the term “suitable for”, which is not enforceable.

Response Message: FR-14-NFPA 24-2019

Public Input No. 19-NFPA 24-2019 [Section No. 7.1.1.3]

**First Revision No. 15-NFPA 24-2019 [Section No. 7.2.3]****7.2.3***

Hydrants shall be located not less than 40 ft (12 m) from the buildings or structures to be protected.

Submitter Information Verification

Committee: AUT-PRI

Submittal Date: Fri Aug 16 09:20:19 EDT 2019

Committee Statement

Committee Statement: Hydrants should not be located closer than 40 ft to protected structures such as cooling towers.

Response Message: FR-15-NFPA 24-2019



First Revision No. 16-NFPA 24-2019 [Sections 7.3.1, 7.3.2]

7.3.1*

Hydrants shall be installed on flat stones, concrete slabs, or other approved materials.

A.7.3.1

See Figure A.7.3.1 . Figure A.7.3.1(a) and Figure A.7.3.1(b) .

Figure A.7.3.1(a) Typical Hydrant Connection with Minimum Height Requirement.

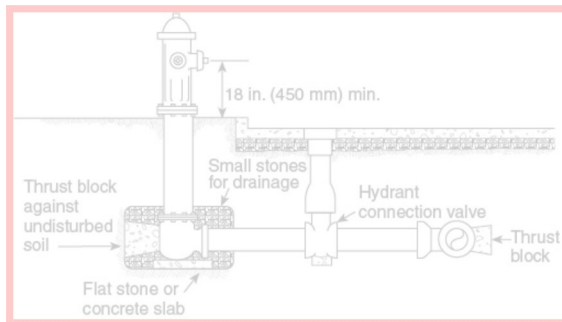

Figure A.7.3.1(b) Typical Hydrant Connection with Maximum Height Requirement.

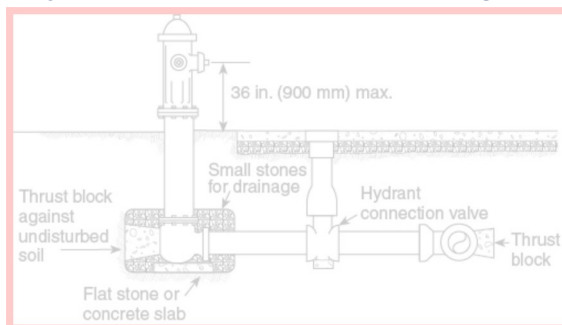
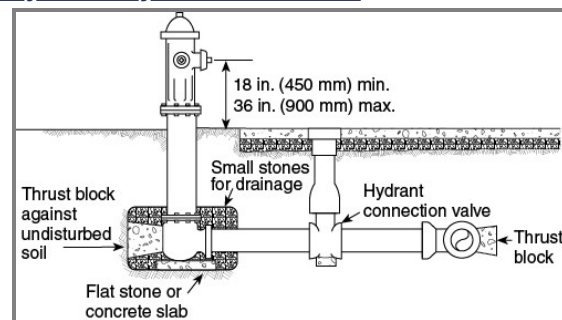

Figure A.7.3.1 Typical Dry Barrel Hydrant Connection.



7.3.2

Small stones or an approved equivalent shall be provided about below and around the drain in an adequate amount to prevent the weep hole from being clogged with native soil, mud, or debris that would prevent adequate drainage for dry barrel hydrants .

7.3.2.1

Where soil is such that the hydrants will not drain properly with the arrangement specified in 7.3.2, or where groundwater stands at levels above that of the drain, the hydrant drain shall be plugged before installation.

7.3.2.1.1*

Hydrants with drain plugs shall be marked to indicate the need for pumping out after usage.

Submitter Information Verification

Committee: AUT-PRI

Submittal Date: Fri Aug 16 09:22:42 EDT 2019

Committee Statement

Committee Statement: This proposal is to clarify that only dry barrel hydrants require a bed of stone for drainage. Wet barrel hydrants are not equipped with drain ports.

This proposal is also to eliminate redundancy. The only difference between the current Figures A.7.3.1(a) and A.7.3.1(b) is the maximum and minimum heights of the hydrant outlets. Those values can be shown on just one illustration.

Additionally, for 7.3.2.1 the word "properly" is proposed to be deleted, because the tem is unenforceable.

Response Message: FR-16-NFPA 24-2019 PI 43 is included as part of FR 16

[Public Input No. 21-NFPA 24-2019 \[Sections 7.3.1, 7.3.2\]](#)

[Public Input No. 43-NFPA 24-2019 \[Section No. 7.3.2 \[Excluding any Sub-Sections\]\]](#)



First Revision No. 18-NFPA 24-2019 [Section No. 7.3.6]

7.3.6

The following shall not be ~~installed in the service stub between~~ installed between a fire hydrant and private water supply piping ~~the control valve for that hydrant~~ :

- (1) Check valves
- (2) Detector check valves
- (3) Backflow prevention valves
- (4) Other similar appurtenances

Submitter Information Verification

Committee: AUT-PRI

Submittal Date: Fri Aug 16 09:30:59 EDT 2019

Committee Statement

Committee Statement: The term "service stub" is not defined. The intention of this section is to not install one of these devices in the hydrant assembly. Realistically, as long as the device has been listed and evaluated, why can't a device such as this be installed?

Response Message: FR-18-NFPA 24-2019

[Public Input No. 51-NFPA 24-2019 \[Section No. 7.3.6\]](#)



First Revision No. 19-NFPA 24-2019 [Section No. 8.2.2]

8.2.2

Hydrants within hose houses shall be ~~as close to~~ located at the front of the house ~~as possible and still~~ allow ~~sufficient room~~ with space behind the doors for the hose gates and the attached hose.

Submitter Information Verification

Committee: AUT-PRI

Submittal Date: Fri Aug 16 09:32:21 EDT 2019

Committee Statement

Committee Statement: This proposal is to eliminate the terms "as possible" and "sufficient", which are not enforceable.

Response Message: FR-19-NFPA 24-2019

[Public Input No. 23-NFPA 24-2019 \[Section No. 8.2.2\]](#)



First Revision No. 20-NFPA 24-2019 [Sections 9.1, 9.2]

9.1* Master Streams.

Master streams shall be delivered by monitor nozzles, hydrant-mounted monitor nozzles, and similar ~~other~~ master stream equipment capable of delivering more than 250 gpm (950 ~~lpm~~ L/min).

9.2 Application and Special Considerations Situations .

Master streams shall be provided as protection for the following:

- (1) Large amounts of combustible materials located in yards
- (2) Average ~~Large~~ amounts of combustible materials in inaccessible locations
- (3) Occupancies presenting special hazards, as required by the ~~authority having jurisdiction~~ AHJ

Submitter Information Verification

Committee: AUT-PRI

Submittal Date: Fri Aug 16 09:33:33 EDT 2019

Committee Statement

Committee Statement: This proposal is to eliminate the terms “similar”, “considerations” and “average”, which are not enforceable.

Additionally, the abbreviation for liters per minute was editorially corrected from “lpm” to “L/min”.

Response Message: FR-20-NFPA 24-2019

[Public Input No. 24-NFPA 24-2019 \[Sections 9.1, 9.2\]](#)



First Revision No. 21-NFPA 24-2019 [Section No. 10.1.1.1]



10.1.1.1 Listing Use .

Piping manufactured in accordance with Table 10.1.1.1 shall be permitted to be used.

Table 10.1.1.1 Manufacturing Standards for Underground Pipe

Materials and Dimensions	Standard
Ductile Iron	
Cement-Mortar Lining for Ductile-Iron Pipe <u>mortar lining for ductile-iron pipe</u> and Fittings <u>fittings</u>	AWWA C104/A21.4
Polyethylene Encasement <u>encasement</u> for Ductile-Iron Pipe Systems <u>ductile-iron pipe systems</u>	AWWA C105/A21.5
Rubber-Gasket Joints for Ductile-Iron Pressure Pipe and Fittings <u>gasket joints for ductile-iron pressure pipe and fittings</u>	AWWA C111/A21.11
Flanged Ductile-Iron Pipe <u>ductile-iron pipe</u> with Ductile-Iron or Gray-Iron Threaded Flanges <u>ductile-iron or gray-iron threaded flanges</u>	AWWA C115/A21.15
Thickness Design <u>design</u> of Ductile-Iron Pipe <u>ductile-iron pipe</u>	AWWA C150/A21.50
Ductile-Iron Pipe, Centrifugally Cast <u>iron pipe, centrifugally cast</u>	AWWA C151/A21.51
Standard for the Installation of Ductile Iron Water Mains <u>iron water mains</u> and Their Appurtenances <u>their appurtenances</u>	AWWA C600
Concrete	
Reinforced Concrete Pressure Pipe, Steel-Cylinder Type <u>concrete pressure pipe, steel-cylinder type</u>	AWWA C300
Prestressed Concrete Pressure Pipe, Steel-Cylinder Type <u>concrete pressure pipe, steel-cylinder type</u>	AWWA C301
Reinforced Concrete Pressure Pipe, Non-Cylinder Type <u>concrete pressure pipe, non-cylinder type</u>	AWWA C302
Reinforced Concrete Pressure Pipe, Steel-Cylinder Type, Pretensioned <u>concrete pressure pipe, steel-cylinder type, pretensioned</u>	AWWA C303
Cement-Mortar <u>mortar</u> Lining <u>lining</u> of Water Pipe Lines <u>water pipe lines</u> in Place <u>place</u> , 4 in. (100 mm) and Larger <u>larger</u>	AWWA C602
Plastic	
Polyvinyl Chloride (PVC) Pressure Pipe <u>pressure pipe</u> and fabricated fittings, 4 in. Through <u>through</u> 60 1/2 in. (100 mm Through <u>through</u> 300 1/500 mm), for Water Transmission and Distribution	AWWA C900
<i>Polyvinyl Chloride (PVC) Pressure Pipe and Fabricated Fittings, 14 in. Through 48 in. (350 mm Through 1200 mm), for Water Transmission and Distribution</i>	AWWA C905
Polyethylene (PE) Pressure Pipe <u>pressure pipe</u> and Fittings <u>fittings</u> , 4 in. (100 mm) Through <u>through</u> 63 in. (1575 mm) for Waterworks <u>waterworks</u>	AWWA C906
Molecularly Oriented Polyvinyl Chloride <u>oriented polyvinyl chloride</u> (PVC0), 4 in. Through <u>through</u> 24 in. (100 mm Through <u>through</u> 600 mm) for Water, Wastewater, <u>water, wastewater,</u> and Reclaimed Water Service <u>reclaimed water service</u>	AWWA C909
Brass	
Specification for Seamless Red Brass Pipe, Standard Sizes <u>red brass pipe, standard sizes</u>	ASTM B43
Copper	
Specification for Seamless Copper Tube <u>copper tube</u>	ASTM B75/B75M
Specification for Seamless Copper Water Tube <u>copper water tube</u>	ASTM B88

Materials and Dimensions	Standard
Requirements for Wrought Seamless Copper <u>seamless copper</u> and Copper-Alloy Tube <u>copper-alloy tube</u>	ASTM B251
Stainless Steel	
Standard Specification for Seamless, Welded <u>welded</u> , and Heavily Cold-Worked Austenitic Stainless Steel Pipes <u>heavily cold worked austenitic stainless steel pipes</u>	ASTM A312/312M

Supplemental Information

File Name	Description Approved
Table_10.1.1.1.xlsx	for staff use

Submitter Information Verification

Committee: AUT-PRI

Submittal Date: Fri Aug 16 09:35:53 EDT 2019

Committee Statement

Committee Statement: There are two changes proposed here. The first is just to change the title of the section from "Listing" to "Uses". This is suggested because the standard does not require a listing. As long as the pipe is manufactured in accordance with the table, it is not required to be listed. If the title "Listing" is used at all, it should be used with 10.1.1.2

The other change is to correct the title of C900 pipe to expand it to 60 inches (1500mm). This is consistent with the change made by the AWWA to consolidate C905 into C900 and get rid of C905. There are no longer two standards. AWWA now uses C900 for all sizes of PVC pipe from small to very large.

Response Message: FR-21-NFPA 24-2019 The table was also revised to remove the title of each referenced standard under the "Materials and Dimensions" heading as it is the intent to list the material and not the standard's title. See attached file

[Public Input No. 46-NFPA 24-2019 \[Section No. 10.1.1.1\]](#)



First Revision No. 48-NFPA 24-2019 [Section No. 10.1.1.3]

10.1.1.3

Steel piping manufactured in accordance with Table 10.1.1.3 that is externally coated and wrapped and internally galvanized shall be permitted to be used between the hose coupling(s) on the fire department connection and the check valve installed in the fire department connection piping.

Table 10.1.1.3 Steel Piping for Fire Department Connections

Materials and Dimensions	Standard
Standard Specification for Black Black and Hot-Dipped Zinc-Coated hot-dipped zinc-coated (Galvanized) Welded (galvanized) welded and Seamless Steel Pipe <u>seamless steel pipe</u> for Fire Protection Use <u>fire protection use</u>	ASTM A795/A795M
Standard Specification for Pipe, Steel, Black Pipe, steel, black and Hot-Dipped, Zinc-Coated, Welded <u>hot-dipped, zinc-coated, welded</u> and Seamless <u>seamless</u>	ASTM A53/A53M
Standard Specification for Electric- Electric-Resistance-Welded Steel Pipe <u>resistance-welded steel pipe</u>	ASTM A135/A135M

10.1.1.3.1

External coating and wrapping as required by 10.1.1.3 shall be approved.

Submitter Information Verification

Committee: AUT-PRI

Submittal Date: Thu Sep 26 10:57:28 EDT 2019

Committee Statement

Committee Statement: Removes the title of the standard under the "Materials and Dimensions" heading since this was not intended to be a listing of standards.

Response Message: FR-48-NFPA 24-2019



First Revision No. 22-NFPA 24-2019 [Section No. 10.1.4]

10.1.4*

Underground Regardless of pipe type, underground piping shall be permitted to extend into the building through the slab or wall not more than 24 in. (600 mm).

10.1.4.1

Underground piping extended vertically into the building through the slab shall be installed plumb.

Submitter Information Verification

Committee: AUT-PRI

Submittal Date: Fri Aug 16 09:36:44 EDT 2019

Committee Statement

Committee Statement: This proposal offered as an attempt to try to eliminate a common site problem, whereby the spigot piece of an underground installation is not installed "true", such that extra fittings or a dutchman or a wedge gasket is needed to align the fire protection system(s) inside the building.

Response Message: FR-22-NFPA 24-2019

[Public Input No. 25-NFPA 24-2019 \[Section No. 10.1.4\]](#)



First Revision No. 23-NFPA 24-2019 [Section No. 10.2.1.1]

10.2.1.1

Fittings manufactured in accordance with Table 10.2.1.1 shall be permitted to be used.

Table 10.2.1.1 Fittings Materials and Dimensions

Materials and Dimensions	Standard
Cast Iron	
Gray Iron Threaded Fittings, Classes <u>iron threaded fittings, classes 125 and 250</u>	ASME B16.4
Gray Iron Pipe Flanges <u>iron pipe flanges</u> and Flanged Fittings <u>flanged fittings</u> , Classes classes 25, 125, and 250	ASME B16.1
Ductile Iron	
Ductile-Iron <u>iron</u> and Gray-Iron Fittings <u>gray-iron fittings</u>	AWWA C110/A21.10
Ductile-Iron Compact Fittings <u>-iron compact fittings</u>	AWWA C153/A21.53
Malleable Iron	
Malleable Iron Threaded Fittings <u>iron threaded fittings</u> , Classes classes 150 and 300	ASME B16.3
Copper	
Wrought copper and copper alloy solder joint pressure fittings	<u>ASME B16.22</u>
Cast copper alloy solder joint pressure fitting	<u>ASME B16.18</u>
Bronze Fittings	
Cast copper alloy threaded fittings, classes 125 and 250	<u>ASME B16.15</u>
Stainless Steel	
Wrought austenitic stainless steel pipe fittings	ASTM <u>A403/A403M</u>

Submitter Information Verification

Committee: AUT-PRI

Submission Date: Fri Aug 16 09:41:24 EDT 2019

Committee Statement

Committee Statement: This proposal seeks to rectify a discrepancy that was introduced during the Second Draft stage of the revision process, when as per Public Comment No. 11, and Second Revision No. 7, it was requested that the references to steel pipe fittings should be deleted from the table. However, for some reason in the TerraView copy of the table, the provisions for copper and bronze fittings were inadvertently shown in “strikeout text” as well, so now, as published, the table only recognizes cast iron and ductile iron fittings as appropriate for underground piping installations.

Additionally, in Public Comment No. 6, it was proposed to add the references for stainless steel fittings, to correspond with the information shown in NFPA 13 - 2016, Table 6.4.1. This matter was “accepted in principle” by the Technical Committee and it was intended to be reflected in Second Revision No. 7, but mistakenly, it was not included.

The missing information needs to be added to Table, 10.2.1.1, to allow the appropriate fittings to be utilized when copper, bronze or stainless steel pipe is employed in underground piping installations.

Also, please note that since Table 10.2.1.1 is extracted into NFPA 13 - 2019 as Table 6.2.1.1, the missing information needs to be added to NFPA 13, Table 6.2.1.1 as well.

Response Message: FR-23-NFPA 24-2019 Removed "specification for" since this table is not intended to be a listing of the standard titles.

[Public Input No. 38-NFPA 24-2019 \[Section No. 10.2.1.1\]](#)



First Revision No. 24-NFPA 24-2019 [Section No. 10.4.3]

10.4.3 Private Fire Service Mains Under Beneath Buildings.

Except as allowed permitted by 10.4.3, private fire service mains shall not be allowed to run installed under beneath buildings.

10.4.3.1*

Private fire service mains supplying fire protection systems within the building shall be permitted to extend horizontally no more than 10 ft (3.0 m) cumulatively, as measured from the outside of the building, under the building to the riser location.

A.10.4.3.1

Items such as sidewalks or patios should not be included as they are no different from roadways. See Figure A.10.4.3.1. The intent of this section is to limit the total length of horizontal pipe beneath the building to not more than 10 ft (3 m). See Figure A.10.4.3.1.

Figure A.10.4.3.1 Riser Entrance Location.

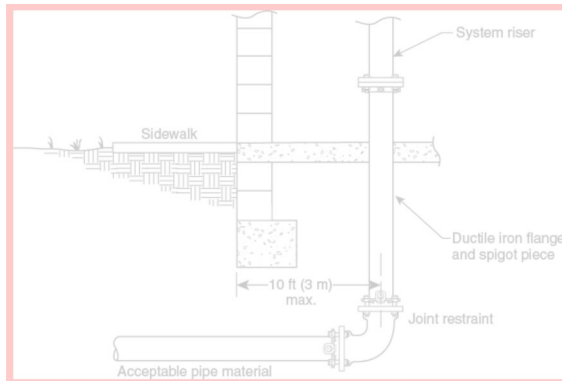
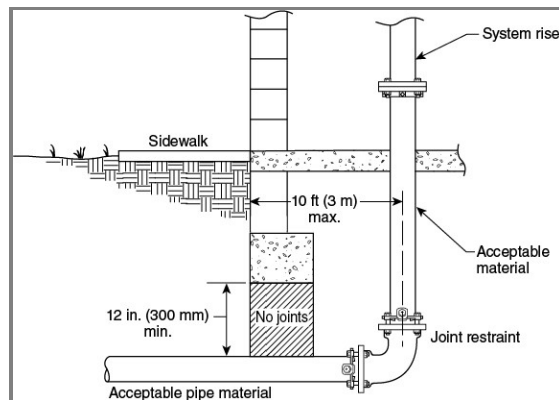

Figure A.10.4.3.1 Riser Entrance Location and Clearance.



10.4.3.1.1*

Pipe joints shall not be located directly under foundation footings.

A.10.4.3.1.1

The individual piping standards should be followed for load and bury depth, accounting for the load and stresses imposed by the building foundation.

Figure A.10.4.3.1.1 shows location where pipe joints would be prohibited.

Figure A.10.4.3.1.1 Pipe Joint Location in Relation to Foundation Footings.

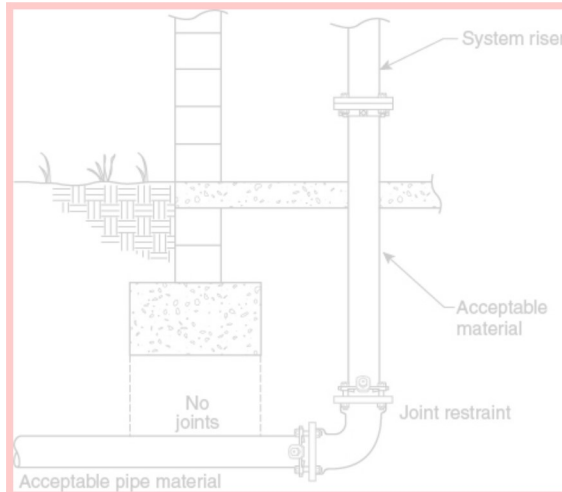
**10.4.3.1.2***

Piping shall be installed a minimum of 12 in. (300 mm) below the bottom of building foundations or footers.

A.10.4.3.1.2

Sufficient clearance should be provided when piping passes beneath foundations or footers. See Figure A.10.4.3.1.2 -

Figure A.10.4.3.1.2 Piping Clearance from Foundation.

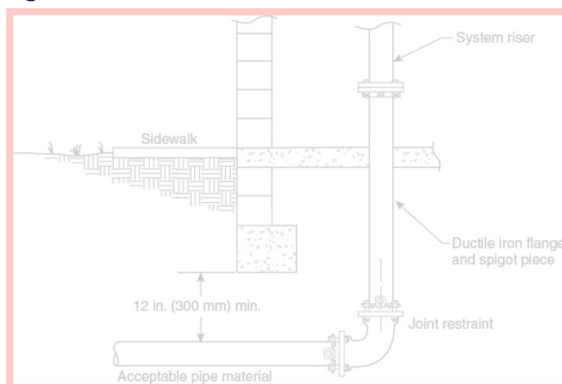
**10.4.3.1.2.1**

The requirements of 10.4.3.1.2 shall not apply when the piping is sleeved with an approved material.

10.4.3.2*

Private fire service mains shall not be permitted to extend more than 10 ft (3 m) under the building except as allowed in 10.4.3.2.1.

10.4.3.2.1*

Where private fire service mains extend more than 10 ft (3 m) into the building, they shall be run in a covered trench.

A.10.4.3.2.1

See [Figure A.10.4.3.2.1](#) .

Figure A.10.4.3.2.1 Private Service Main in a Covered Trench.

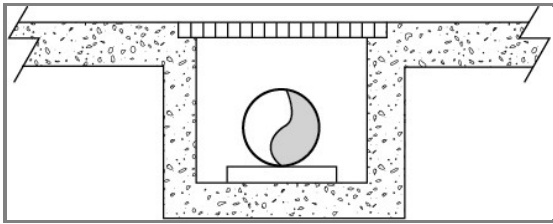
**10.4.3.2.1.1***

The trench shall be accessible from within the building.

10.4.3.2.1.2

The trench shall have rigid walls and a base.

10.4.3.2.1.3

The trench shall be constructed of noncombustible materials.

10.4.3.2.1.4*

Provisions for draining water shall be provided for the trench.

10.4.3.2.1.5

Where the piping in the trench is installed under foundations or footers, clearance shall be provided in accordance with 10.4.3.1.2 or 10.4.3.1.2.1.

10.4.3.2.2

Piping in the trench shall be permitted to be in accordance with 10.1.1.

10.4.3.2.2.1

Aboveground piping in accordance with NFPA 13 shall be permitted to be used.

10.4.3.2.2.2

Where piping installed in the trench is in accordance with 10.1.1, all joints shall be restrained in accordance with 10.6.2 or 10.6.3.

10.4.3.2.3*

Where piping is installed in a trench as permitted by 10.4.3.2.1, a valve shall be provided where the underground piping enters the trench.

10.4.3.2.4

When piping is installed in a trench, bury depths of 10.4.2.2 shall not apply.

10.4.3.2.4.1

Piping in the trench shall be protected from freezing in accordance with 10.4.2.1.4.

Submitter Information Verification

Committee: AUT-PRI

Submittal Date: Fri Aug 16 09:41:51 EDT 2019

Committee Statement

Committee Statement: This proposal is to eliminate the word "allowed", which is used twice in the current 10.4.3 and to eliminate redundancy. and to provide an illustration of a main being run in a covered trench below the floor.

The only significant difference between the current Figures A.10.4.3.1, A.10.4.3.1.1 and

A.10.4.3.1.2 is the maximum distance inside the building, the minimum distance below the footing and the area below the footing where no joints are allowed. Those matter can be shown on just one illustration.

These actions call for the asterix (*) for Sections 10.4.3.1.1 and 10.4.3.1.2 to be deleted and for a new asterix (*) to be added to Section 10.4.3.2.1.

**Response
Message:**

FR-24-NFPA 24-2019

[Public Input No. 26-NFPA 24-2019 \[Section No. 10.4.3\]](#)

**First Revision No. 25-NFPA 24-2019 [Section No. 10.6.2]****10.6.2* Restrained Joint Systems.**

Private fire service mains using restrained joint systems shall include one or more of the following:

- (1) Locking Listed locking mechanical or push-on joints
- (2) Mechanical Listed mechanical joints utilizing setscrew retainer glands
- (3) Listed bell joint restraints
- (4) Bolted flange joints
- (5) Pipe clamps and tie rods in accordance with 10.6.2.1
- (6) Other approved methods or devices

10.6.2.1* Sizing Clamps, Rods, Bolts, and Washers.**A.10.6.2.1**

Examples of materials and the standards covering these materials are as follows:

- (1) Clamps, steel
- (2) Rods, steel
- (3) Bolts, steel (ASTM A307, *Standard Specification for Carbon Steel Bolts, Studs, Threaded Rod 60,000 PSI Tensile Strength*)
- (4) Washers, steel, cast iron (Class A cast iron as defined by ASTM A126, *Standard Specification for Gray Iron Castings for Valves, Flanges and Pipe Fittings*)
- (5) Anchor straps, plug straps, steel
- (6) Rod couplings, turnbuckles, malleable iron (ASTM A197/A197M, *Standard Specification for Cupola Malleable Iron*)

~~The materials specified in A.10.6.2.1(1) through A.10.6.2.1(6) do not preclude the use of other materials that also satisfy the requirements of this section.~~

10.6.2.1.1 Clamps.**10.6.2.1.1.1**

Clamps shall have the following dimensions:

- (1) ½ in. × 2 in. (13 mm × 50 mm) for 4 in. (100 mm) to 6 in. (150 mm) pipe
- (2) ⅝ in. × 2½ in. (16 mm × 65 mm) for 8 in. (200 mm) to 10 in. (250 mm) pipe
- (3) ⅝ in. × 3 in. (16 mm × 75 mm) for 12 in. (300 mm) pipe

10.6.2.1.1.2

The diameter of a bolt hole shall be ⅛ in. (3 mm) larger than that of the corresponding bolt.

10.6.2.1.2 Rods.**10.6.2.1.2.1**

Rods shall be not less than ⅝ in. (16 mm) in diameter.

10.6.2.1.2.2

Table 10.6.2.1.2.2 provides the numbers of various diameter rods that shall be used for a given pipe size.

Table 10.6.2.1.2.2 Rod Number — Diameter Combinations

Nominal Pipe Size (in.) (mm)		5/8 in. (16 mm)	3/4 in. (19 mm)	7/8 in. (22 mm)	1 in. (25 mm)
in.	mm				
4 (100)	100	2	—	—	—
6 (150)	150	2	—	—	—
8 (200)	200	3	2	—	—
10 (250)	250	4	3	2	—
12 (300)	300	6	4	3	2
14 (350)	350	8	5	4	3
16 (400)	400	10	7	5	4

Note: This table has been derived using pressure of 225 psi (15.5 bar) and design stress of 25,000 psi (172.4 MPa).

10.6.2.1.2.3

Where using bolting rods, the diameter of mechanical joint bolts shall limit the diameter of rods to 3/4 in. (20 mm).

10.6.2.1.2.4

Threaded sections of rods shall not be formed or bent.

10.6.2.1.2.5

Where using clamps, rods shall be used in pairs for each clamp.

10.6.2.1.2.6

Assemblies in which a restraint is made by means of two clamps canted on the barrel of the pipe shall be permitted to use one rod per clamp if approved for the specific installation by the AHJ.

10.6.2.1.2.7

Where using combinations of rods, the rods shall be symmetrically spaced.

10.6.2.1.3 Clamp Bolts.

Clamp bolts shall have the following diameters:

- (1) 5/8 in. (16 mm) for pipe 4 in. (100 mm), 6 in. (150 mm), and 8 in. (200 mm)
- (2) 3/4 in. (20 mm) for 10 in. (250 mm) pipe
- (3) 7/8 in. (22 mm) for 12 in. (300 mm) pipe

10.6.2.1.4 Washers.**10.6.2.1.4.1**

Washers shall be permitted to be cast iron or steel and round or square.

10.6.2.1.4.2

Cast iron washers shall have the following dimensions:

- (1) 5/8 in. × 3 in. (16 mm × 75 mm) for 4 in. (100 mm), 6 in. (150 mm), 8 in. (200 mm), and 10 in. (250 mm) pipe
- (2) 3/4 in. × 3 1/2 in. (20 mm × 90 mm) for 12 in. (300 mm) pipe

10.6.2.1.4.3

Steel washers shall have the following dimensions:

- (1) 1/2 in. × 3 in. (13 mm × 75 mm) for 4 in. (100 mm), 6 in. (150 mm), 8 in. (200 mm), and 10 in. (250 mm) pipe
- (2) 1/2 in. × 3.5 in. (13 mm × 90 mm) for 12 in. (300 mm) pipe

10.6.2.1.4.4

The diameter of holes shall be $\frac{1}{8}$ in. (3 mm) larger than that of bolts or rods.

10.6.2.2 Sizes of Restraint Straps for Tees.**10.6.2.2.1**

Restraint straps for tees shall have the following dimensions:

- (1) $\frac{5}{8}$ in. (16 mm) thick and $2\frac{1}{2}$ in. (65 mm) wide for 4 in. (100 mm), 6 in. (150 mm), 8 in. (200 mm), and 10 in. (250 mm) pipe
- (2) $\frac{5}{8}$ in. (16 mm) thick and 3 in. (75 mm) wide for 12 in. (300 mm) pipe

10.6.2.2.2

The diameter of rod holes shall be $\frac{1}{16}$ in. (1.6 mm) larger than that of rods.

10.6.2.2.3

Figure 10.6.2.2.3 and Table 10.6.2.2.3 shall be used in sizing the restraint straps for both mechanical and push-on joint tee fittings.

Figure 10.6.2.2.3 Restraint Straps for Tees.

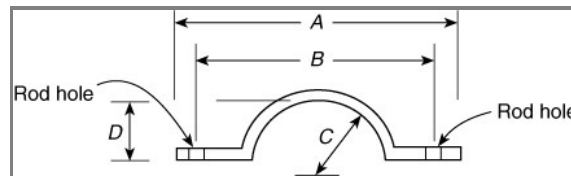

Table 10.6.2.2.3 Restraint Straps for Tees

Nominal Pipe Size (in.)(mm)		A		B		C		D	
in.	mm	in.	mm	in.	mm	in.	mm	in.	mm
4 (100)	100	12 $\frac{1}{2}$	315	10 $\frac{1}{8}$	255	2 $\frac{1}{2}$	65	1 $\frac{3}{4}$	45
6 (150)	150	14 $\frac{1}{2}$	365	12 $\frac{1}{8}$	305	3 $\frac{9}{16}$	90	2 $\frac{13}{16}$	70
8 (200)	200	16 $\frac{3}{4}$	420	14 $\frac{3}{8}$	360	4 $\frac{21}{32}$	115	3 $\frac{29}{32}$	100
10 (250)	250	19 $\frac{1}{16}$	475	16 $\frac{11}{16}$	415	5 $\frac{3}{4}$	145	5	125
12 (300)	300	22 $\frac{5}{16}$	560	19 $\frac{3}{16}$	480	6 $\frac{3}{4}$	170	5 $\frac{7}{8}$	145

10.6.2.3 Sizes of Plug Strap for Bell End of Pipe.**10.6.2.3.1**

The strap shall be $\frac{3}{4}$ in. (20 mm) thick and $2\frac{1}{2}$ in. (65 mm) wide.

10.6.2.3.2

The strap length shall be the same as dimension A for tee straps as shown in Figure 10.6.2.2.3.

10.6.2.3.3

The distance between the centers of rod holes shall be the same as dimension B for tee straps as shown in Figure 10.6.2.2.3.

10.6.2.4 Material.

Clamps, rods, rod couplings or turnbuckles, bolts, washers, restraint straps, and plug straps shall be of a material that has physical and chemical characteristics that indicate its deterioration under stress can be predicted with reliability.

10.6.2.5 Corrosion Resistance.

After installation, rods, nuts, bolts, washers, clamps, and other restraining devices shall be cleaned and thoroughly coated with a bituminous or other acceptable corrosion-retarding material.

10.6.2.5.1

The requirements of 10.6.2.5 shall not apply to epoxy-coated fittings, valves, glands, or other accessories.

Supplemental Information

File Name	Description	Approved
FR-25_A.10.6.2.5_legislative_changes.docx	annex changes. For staff use	

Submitter Information Verification

Committee: AUT-PRI

Submittal Date: Fri Aug 16 09:58:49 EDT 2019

Committee Statement

Committee Statement: Clarifies restrained joint systems

Annex: Moved to a more appropriate section.

Response Message: FR-25-NFPA 24-2019 PI 52 is part of FR 25 remove word "acceptable"

[Public Input No. 52-NFPA 24-2019 \[Section No. 10.6.2.5\]](#)

**First Revision No. 27-NFPA 24-2019 [Section No. 10.7.1.1.1]****10.7.1.1.1**

The restraint specified in 10.7.1.1 shall be to natural rock or to suitable piles or piers built on the downhill side of the bell.

Submitter Information Verification

Committee: AUT-PRI

Submittal Date: Fri Aug 16 10:11:27 EDT 2019

Committee Statement

Committee Statement: This proposal is to eliminate the word “suitable”, which is not enforceable.

Additionally, the option to restrain the pipe with piles is proposed, as an option to building piers.

Response Message: FR-27-NFPA 24-2019

[Public Input No. 27-NFPA 24-2019 \[Section No. 10.7.1.1.1\]](#)



First Revision No. 28-NFPA 24-2019 [Section No. 10.8.5]

10.8.5

All piping, fittings, valves, and hydrants shall be examined for cracks or other defects while suspended above the trench and lowered into the trench using ~~appropriate~~ equipment designed for such use .

Submitter Information Verification

Committee: AUT-PRI

Submittal Date: Fri Aug 16 10:11:49 EDT 2019

Committee Statement

Committee Statement: This proposal is to eliminate the word "appropriate", which is not enforceable.

Response Message: FR-28-NFPA 24-2019

[Public Input No. 28-NFPA 24-2019 \[Section No. 10.8.5\]](#)



First Revision No. 29-NFPA 24-2019 [Section No. 10.10.1]

10.10.1* Approval of Underground Piping.

The installing contractor shall be responsible for the following:

- (1) Notifying the AHJ and the owner's representative of the time and date testing is to be performed
- (2) Performing all required acceptance tests
- (3) Completing and signing the a contractor's material and test certificate(s) shown in Figure 10.10.1 documenting all required test criteria

Figure 10.10.1 Sample of Contractor's Material and Test Certificate for Underground Piping.

Contractor's Material and Test Certificate for Underground Piping	
<p>PROCEDURE Upon completion of work, inspection and tests shall be made by the contractor's representative and witnessed by an owner's representative. All defects shall be corrected and system left in service before contractor's personnel finally leave the job. A certificate shall be filled out and signed by both representatives. Copies shall be prepared for approving authorities, owners, and contractor. It is understood the owner's representative's signature in no way prejudices any claim against contractor for faulty material, poor workmanship, or failure to comply with approving authority's requirements or local ordinances.</p>	
Property name	Date
Property address	
Accepted by approving authority (name)	
Address	
Plans	Installation conforms to accepted plans <input type="checkbox"/> Yes <input type="checkbox"/> No
	Equipment used is approved <input type="checkbox"/> Yes <input type="checkbox"/> No If no, state deviations
Instructions	Has person in charge of the equipment been instructed as to location of control valves and care and maintenance of this new equipment? <input type="checkbox"/> Yes <input type="checkbox"/> No If no, explain
	Have copies of appropriate instructions and care and maintenance charts been provided to the owner or owner's representative? <input type="checkbox"/> Yes <input type="checkbox"/> No If no, explain
Location	
Supplies buildings	
Underground pipes and joints	Pipe types and class <input type="text"/> Type joint <input type="text"/>
	Pipe conforms to _____ standard <input type="checkbox"/> Yes <input type="checkbox"/> No
	Fittings conform to _____ standard <input type="checkbox"/> Yes <input type="checkbox"/> No If no, explain
	Joints needing anchorage clamped, strapped, or blocked in accordance with _____ standard <input type="checkbox"/> Yes <input type="checkbox"/> No If no, explain
Test description	Flushing: Flow the required rate until water is verified to be clear of debris at outlets such as hydrants and blow-offs. Flush at one of the flow rates as specified in 10.10.2.1.3.
	Hydrostatic: All piping and attached appurtenances subjected to system working pressure shall be hydrostatically tested at 200 psi (13.8 bar) or 50 psi (3.4 bar) in excess of the system working pressure, whichever is greater, and shall maintain that pressure ± 5 psi (0.34 bar) for 2 hours. Hydrostatic Sealing Allowance: Where additional water is added to the system to maintain the test pressure required by 10.10.2.2.1, the amount of water shall be measured and shall not exceed the limits of the following equation (for metric equation, see 10.10.2.2.5): $L = \frac{SD \cdot PF}{148,000}$ L = testing allowance (makeup water), in gallons per hour (gpm) S = length of pipe tested, in feet (ft) D = nominal diameter of the pipe, in inches (in) P = average test pressure during the hydrostatic test, in pounds per square inch (gauge) (bar)
Flushing tests	New underground piping flushed according to standard by (company) <input type="checkbox"/> Yes <input type="checkbox"/> No If no, explain
	How flushing flow was obtained <input type="checkbox"/> Public water <input type="checkbox"/> Tank or reservoir <input type="checkbox"/> Fire pump <input type="checkbox"/> Hydrant butt <input type="checkbox"/> Open pipe Lead-in flushed according to _____ standard by (company) <input type="checkbox"/> Yes <input type="checkbox"/> No If no, explain
Flushing tests	How flushing flow was obtained <input type="checkbox"/> Public water <input type="checkbox"/> Tank or reservoir <input type="checkbox"/> Fire pump <input type="checkbox"/> Y connection to flange and spigot <input type="checkbox"/> Open pipe
© 2018 National Fire Protection Association NFPA 24 (p. 1 of 2)	

Hydrostatic test	All new underground piping hydrostatically tested at _____ psi (bar) for _____ hours	Joints covered <input type="checkbox"/> Yes <input type="checkbox"/> No
Leakage test	Total amount of leakage measured _____ gallons (liters) _____ hours	
	Allowable leakage _____ gallons (liters) _____ hours	
Forward flow test of backflow preventer	Forward flow test performed in accordance with 10.10.2.5.2: <input type="checkbox"/> Yes <input type="checkbox"/> No	
Hydrants	Number installed _____ Type and make _____ All operate satisfactorily <input type="checkbox"/> Yes <input type="checkbox"/> No	
Control valves	Water control valves left wide open <input type="checkbox"/> Yes <input type="checkbox"/> No If no, state reason _____	
Remarks	Have threads of fire department connections and hydrants interchangeable with those of fire department answering alarm? <input type="checkbox"/> Yes <input type="checkbox"/> No	
	Date left in service _____	
Signatures	Name of installing contractor _____	
	For property owner (signed) _____ Title _____ Date _____	Tests witnessed by
	For installing contractor (signed) _____ Title _____ Date _____	
Additional explanation and notes		
© 2018 National Fire Protection Association NFPA 24 (p. 2 of 2)		

A.10.10.1

See [Figure A.10.10.1](#).

Figure A.10.10.1 Sample of Contractor's Material and Test Certificate for Underground Piping.

Contractor's Material and Test Certificate for Underground Piping			
PROCEDURE Upon completion of work, inspection and tests shall be made by the contractor's representative and witnessed by an owner's representative. All defects shall be corrected and system left in service before contractor's personnel finally leave the job. A certificate shall be filled out and signed by both representatives. Copies shall be prepared for approving authorities, owners, and contractor. It is understood the owner's representative's signature in no way prejudices any claim against contractor for faulty material, poor workmanship, or failure to comply with approving authority's requirements or local ordinances.			
Property name _____		Date _____	
Property address _____			
Accepted by approving authorities (names) _____			
Plans	Address _____		
	Installation conforms to accepted plans _____	<input type="checkbox"/> Yes <input type="checkbox"/> No	
	Equipment used is approved _____ If no, state deviations _____	<input type="checkbox"/> Yes <input type="checkbox"/> No	
Instructions	Has person in charge of the equipment been instructed as to location of control valves and care and maintenance of this new equipment? If no, explain _____		
	Have copies of appropriate instructions and care and maintenance charts been provided to the owner or owner's representative? If no, explain _____		
Location	Supplier buildings _____		
	Pipe types and class _____	Type joint _____	
Underground pipes and joints	Pipe conforms to _____ standard _____	<input type="checkbox"/> Yes <input type="checkbox"/> No	
	Fittings conform to _____ standard _____ If no, explain _____	<input type="checkbox"/> Yes <input type="checkbox"/> No	
	Joints needing anchorage clamped, strapped, or blocked in accordance with _____ standard _____ If no, explain _____	<input type="checkbox"/> Yes <input type="checkbox"/> No	
Test description	Flushing: Flow the required rate until water is verified to be clear of debris at outlets such as hydrants and blow-offs. Flush at one of the flow rates as specified in 10.10.2.1.3. Hydrostatic: All piping and attached appurtenances subjected to system working pressure shall be hydrostatically tested at 200 psi (13.8 bar) or 50 psi (3.4 bar) in excess of the system working pressure, whichever is greater, and shall maintain that pressure 45 psi (3.1 bar) for 2 hours. Hydrostatic Testing Allowance: Where additional water is added to the system to maintain the test pressures required by 10.10.2.2.1, the amount of water shall be measured and shall not exceed the limits of the following equation for metric equation, see 10.10.2.2.6: $L = \frac{SD\sqrt{P}}{148,000}$ L = testing allowance (makeup water) in gallons per hour (gpm) S = length of pipe tested, in feet (m) D = nominal diameter of the pipe, in inches (mm) P = average test pressure during the hydrostatic test, in pounds per square inch (gauge) (bar)		
	New underground piping flushed according to standard by (company) _____ <input type="checkbox"/> Yes <input type="checkbox"/> No If no, explain _____		
Flushing tests	How flushing flow was obtained <input type="checkbox"/> Public water <input type="checkbox"/> Tank or reservoir <input type="checkbox"/> Fire pump <input type="checkbox"/> Hydrant but <input type="checkbox"/> Open pipe	Through what type opening <input type="checkbox"/> Hydrant but <input type="checkbox"/> Open pipe	
	Lead-ins flushed according to _____ standard by (company) _____ <input type="checkbox"/> Yes <input type="checkbox"/> No If no, explain _____		
	How flushing flow was obtained <input type="checkbox"/> Public water <input type="checkbox"/> Tank or reservoir <input type="checkbox"/> Fire pump <input type="checkbox"/> Y connection to flange and spigot <input type="checkbox"/> Open pipe		
© 2021 National Fire Protection Association NFPA 24 (p. 1 of 2)			
Hydrostatic test	All new underground piping hydrostatically tested at _____ psi (bar) for _____ hours	Joints covered <input type="checkbox"/> Yes <input type="checkbox"/> No	
Leakage test	Total amount of leakage measured _____ gallons (liters) _____ hours		
	Allowable leakage _____ gallons (liters) _____ hours		
Forward flow test of backflow preventer	Forward flow test performed in accordance with 10.10.2.5.2: _____ <input type="checkbox"/> Yes <input type="checkbox"/> No		
Hydrants	Number installed _____ Type and make _____	All operate satisfactorily <input type="checkbox"/> Yes <input type="checkbox"/> No	
Control valves	Water control valves left wide open _____ If no, state reason _____		
	Hose threads of fire department connections and hydrants interchangeable with those of fire department answering alarm _____ <input type="checkbox"/> Yes <input type="checkbox"/> No		
Remarks	Date left in service _____		
	Name of installing contractor _____		
Signatures	Tests witnessed by _____		
	For property owner (signed) _____ Title _____ Date _____		
	For installing contractor (signed) _____ Title _____ Date _____		
Additional explanation and notes _____			
© 2021 National Fire Protection Association NFPA 24 (p. 2 of 2)			

Submitter Information Verification

Committee: AUT-PRI

Submission Date: Fri Aug 16 10:13:57 EDT 2019

Committee Statement

Committee Statement: The current test certificates have not been updated for many cycles. It appears that the current code requires contractors to use the form found in figure 10.10.1 without modification. Several companies have moved to digital forms which are easier to read and edit on a screen and allow for digital signatures. Many of these companies have made modifications to their digital forms to provide various improvements to the current certificate:

1. Added important information found in the acceptance chapter that is not found on the form (for example, backfilling of trench)

2. Reconfiguring the form based on the party responsible for the data entry. The form requires input that is typically supplied by multiple parties. (for example, the designer, the project manager, and the fitter). The portion to be supplied by each party is scattered throughout the document making it difficult to fill out correctly. Usually this form is partially filled out by the designer (material and design criteria), then the project manager provides additional information (welding, O&Ms, etc.), and then the fitter supplies the testing results.

3. Reconfiguring the form based on the natural sequence of the testing. Most systems are hydrostatically tested weeks before the alarms are installed and ready for testing. Most system are trip and alarm tested before owner training is scheduled. Following the natural order makes the form more self-documenting, provides better instruction, and ensures completion.

4. Modify for multiple signatures. There is only one spot on this form for a signature even though multiple activities are covered by these forms which often take place by different people at separate occasions. Often, AHJs and GCs require paperwork to be submitted after each activity, resulting in the submission of incomplete forms, which looks bad and can expose one to liability.

5. A smart, digital form or software package could collect just the relevant information needed for acceptance, reducing the number of blank fields and duplicate entries. Modern software can not only make completing the form easier, but can also distribute the completed form for digital signatures, and archive the certificates in cloud storage.

6. Add additional instruction or legal language. The one-size-fits-all form prevents contractors from including important instruction or legal verbiage that may protect them from future legal action.

By moving this form to the annex, contractors will have the ability to tailor a form to be pertinent to the particular project. (This may be a Task Group project to update and modernize these forms.

This concept if accepted needs to be correlated with NFPA 24 and NFPA 13. Similar PI have been submitted to NFPA 13

Response Message: FR-29-NFPA 24-2019

[Public Input No. 48-NFPA 24-2019 \[Section No. 10.10.1\]](#)

[Public Input No. 50-NFPA 24-2019 \[Global Input\]](#)



First Revision No. 30-NFPA 24-2019 [Section No. 10.10.2.1.3 [Excluding any Sub-Sections]]

The minimum rate of flow shall be in accordance with Table 10.10.2.1.3.

Table 10.10.2.1.3 Flow Required to Produce Velocity of 10 ft/sec (3.0 m/sec) in Pipes

Nominal Pipe Size (in.)	Flow Rate (gpm)	Nominal Pipe Size (mm)	Flow Rate (L/min)
2	100	50	380
2½	150	65	570
3	220	80 <u>75</u>	833
4	390	100	1,500
5	610	125	2,300
6	880	150	3,350
8	1,560	200	5,900
10	2,440	250	9,250
12	3,520	300	13,300

Submitter Information Verification

Committee: AUT-PRI

Submittal Date: Fri Aug 16 10:23:13 EDT 2019

Committee Statement

Committee Statement: To align the format of the table with similar tables in NFPA 20

Response Message: FR-30-NFPA 24-2019

[Public Input No. 39-NFPA 24-2019 \[Section No. 10.10.2.1.3 \[Excluding any Sub-Sections\]\]](#)



First Revision No. 31-NFPA 24-2019 [Section No. 10.10.2.1.3.1]

10.10.2.1.3.1

Where the flow rates established in Table 10.10.2.1.3 are not attainable, the maximum allowable flow rate available at the minimum allowable residual pressure to the system shall be acceptable.

Submitter Information Verification

Committee: AUT-PRI

Submittal Date: Fri Aug 16 10:24:58 EDT 2019

Committee Statement

Committee Statement: This proposal is offered to clarify the acceptable flow rate if the values from Table 10.10.2.1.3 cannot be obtained. Many municipalities do not allow residual pressures to fall below 20 psi, so while more flow might be "available" at lesser pressures, the "allowable" flow rate would be somewhat less.

Response Message: FR-31-NFPA 24-

[Public Input No. 29-NFPA 24-2019 \[Section No. 10.10.2.1.3.1\]](#)

[Public Input No. 4-NFPA 24-2018 \[Section No. 10.10.2.1.3.1\]](#)

**First Revision No. 32-NFPA 24-2019 [Section No. 10.10.2.1.4]****10.10.2.1.4***

In lieu of flushing with the waterflow rates prescribed in 10.10.2.1.3 and 10.10.2.1.3.1 , water main cleaning of the piping by the forceful introduction of swabs through the pipe shall be permitted.

A.10.10.2.1.4

An example of a swab would be polyurethane foam. The manufacturer's recommended procedure should be followed when swabbing is used.

10.10.2.1.4.1

Water main swabbing shall be repeated, as necessary, until the last swab that has fully penetrated the pipe is clean and the discharge water is clear.

10.10.2.1.5

Provision shall be made for the proper disposal of water used for flushing or testing to minimize any water damage caused by the discharge .

Submitter Information Verification

Committee: AUT-PRI

Submittal Date: Fri Aug 16 10:28:58 EDT 2019

Committee Statement

Committee Statement: This proposal is for a new Section 10.10.2.1.4 for an alternate cleaning procedure, in lieu of the tradition flushing. Water conservation has become a very large issue in many regions and the water flow rates prescribed by the standard are very high and often not permitted by the municipal authority. Water main swabbing is an excellent alternative to the current flushing requirements. It is more obtrusive than flushing and thus more effective and can use significantly less water to achieve the desired results.

Please note, this is similar to Public Comment 12, from the previous revision cycle, which was held, because at that time it was considered to be new material.

This proposal is also to eliminate the word "proper" from the existing Section 10.10.2.1.4 (now proposed as 10.10.2.1.5), which is not enforceable, and to provide additional text to help clarify what is meant by "disposal".

Response Message: FR-32-NFPA 24-2019 PI 41 is included in FR32

[Public Input No. 30-NFPA 24-2019 \[Section No. 10.10.2.1.4\]](#)

[Public Input No. 41-NFPA 24-2019 \[New Section after 10.10.2.1.4\]](#)



First Revision No. 33-NFPA 24-2019 [Section No. 10.10.2.2.2]

10.10.2.2.2

Acceptable Successful test results shall be determined by indication of either a pressure loss less than gauge pressure of 5 psi (0.3 bar) or by no visual leakage.

Submitter Information Verification

Committee: AUT-PRI

Submittal Date: Fri Aug 16 10:57:52 EDT 2019

Committee Statement

Committee Statement: Editorial

Response Message: FR-33-NFPA 24-2019



First Revision No. 40-NFPA 24-2019 [New Section after 10.10.2.3]

10.10.2.3.1*

For existing system modifications or repairs that cannot be isolated, hydrostatic testing shall be limited to visual evidence of leakage at system, working pressure.

A.10.10.2.3.1

Examples include cut-in tees, repair sleeves, or hot taps.

Submitter Information Verification

Committee: AUT-PRI

Submittal Date: Fri Aug 16 11:52:25 EDT 2019

Committee Statement

Committee Statement: Addresses situations where existing systems cannot be isolated for hydrotesting.

Response Message: FR-40-NFPA 24-2019

**First Revision No. 34-NFPA 24-2019 [Sections 10.10.2.4.2, 10.10.2.4.3]****10.10.2.4.2**

Dry barrel hydrants shall be checked for ~~proper~~ drainage.

10.10.2.4.3

All control valves shall be fully closed and opened under system water pressure to ensure ~~proper~~ operation.

Submitter Information Verification

Committee: AUT-PRI

Submittal Date: Fri Aug 16 10:58:22 EDT 2019

Committee Statement

Committee Statement: This proposal is to eliminate the word “proper”, which is not enforceable.

Response Message: FR-34-NFPA 24-2019 PI 7 is resolved - submitter did not provide proposed language or means to complete the intended task.

[Public Input No. 32-NFPA 24-2019 \[Sections 10.10.2.4.2, 10.10.2.4.3\]](#)

[Public Input No. 7-NFPA 24-2018 \[New Section after 10.10.2.4.3\]](#)



First Revision No. 35-NFPA 24-2019 [Section No. 10.10.2.5.1]

10.10.2.5.1

The backflow prevention assembly shall be forward flow tested ~~to ensure proper operation~~ .

Submitter Information Verification

Committee: AUT-PRI

Submittal Date: Fri Aug 16 11:00:14 EDT 2019

Committee Statement

Committee Statement: This proposal is to eliminate the word "proper", which is not enforceable.

The additional text is proposed, to clarify the goal of the forward flow test.

Response Message: FR-35-NFPA 24-2019

[Public Input No. 33-NFPA 24-2019 \[Section No. 10.10.2.5.1\]](#)



First Revision No. 36-NFPA 24-2019 [New Section after 11.2]

11.1 Hydraulic Calculation Procedures.

Hydraulic calculations of system piping where required shall be in accordance with NFPA 13.

Submitter Information Verification

Committee: AUT-PRI

Submittal Date: Fri Aug 16 11:03:33 EDT 2019

Committee Statement

Committee Statement: This proposal offered to provide additional instruction concerning hydraulic calculation procedures. Currently NFPA 24 does not contain any information concerning C-factors, fitting equivalents, adjustments, etc.

Response Message: FR-36-NFPA 24-2019

Public Input No. 34-NFPA 24-2019 [New Section after 11.2]



First Revision No. 37-NFPA 24-2019 [Section No. 13.3]

13.3 Mains Supplying Fire Protection Systems.

The size of private fire service mains supplying fire protection systems shall be approved by the authority having jurisdiction, and based on the following factors shall be considered :

- (1) Construction and occupancy of the ~~plant~~ building or structure
- (2) Fire flow and pressure of the water required
- (3) Adequacy of the water supply

Submitter Information Verification

Committee: AUT-PRI

Submittal Date: Fri Aug 16 11:13:34 EDT 2019

Committee Statement

Committee Statement: This proposal is to eliminate the word "considered", which is not enforceable.

Response Message: FR-37-NFPA 24-2019

[Public Input No. 35-NFPA 24-2019 \[Section No. 13.3\]](#)



First Revision No. 38-NFPA 24-2019 [Section No. 14.1]

14.1 General.

A private fire service main and its appurtenances installed in accordance with this standard shall be properly inspected, tested, and maintained in accordance with NFPA 25 to provide at least the same level of performance and protection as designed .

Submitter Information Verification

Committee: AUT-PRI

Submittal Date: Fri Aug 16 11:15:14 EDT 2019

Committee Statement

Committee Statement: This proposal is to eliminate the word “properly”, which is not enforceable.

This proposal also suggests revised wording, more in line with the Purpose of NFPA 25, since that standard does not endeavor to verify the adequacy of the design of the system. As explained in Section A.1.1.3.1 of NFPA 25: “The requirement to evaluate the adequacy of the design of the installed system or the capability of the fire protection system to protect the building or its contents, is not a part of the periodic inspection, testing, and maintenance requirements of this standard.”

Response Message: FR-38-NFPA 24-2019

[Public Input No. 36-NFPA 24-2019 \[Section No. 14.1\]](#)



First Revision No. 39-NFPA 24-2019 [Section No. A.10.4.2]

A.10.4.2

As there is normally no circulation of water in private fire mains, they require greater depth of covering than do public mains. Greater depth is required in a loose gravelly soil (or in rock) than in compact soil containing large quantities of clay. The recommended depth of cover above the top of underground yard mains is shown in Figure A.10.4.2(a) Figure A.10.4.2 .

Figure A.10.4.2 Recommended Depth of Cover (in feet) Above Top of Underground Yard Mains.

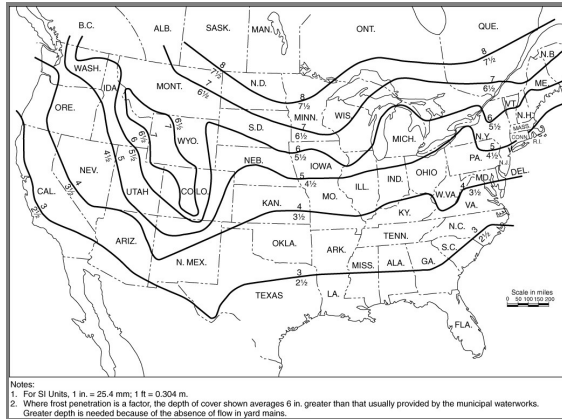

In determining the need to protect aboveground piping from freezing, the lowest mean temperature should be considered as shown in Figure A.10.4.2(b) .

Figure A.10.4.2(b) Isothermal Lines — Lowest One-Day Mean Temperature (°F).

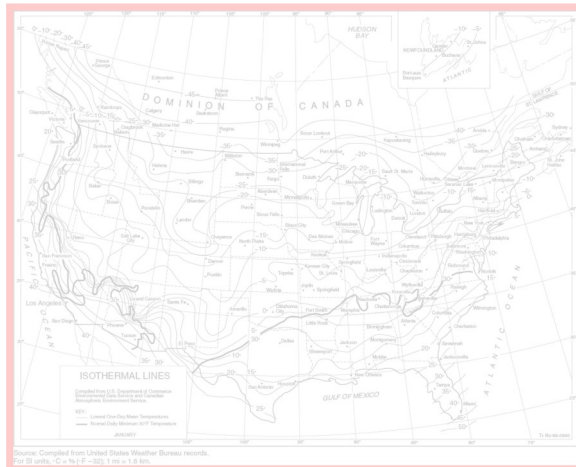

Submitter Information Verification

Committee: AUT-PRI

Submission Date: Fri Aug 16 11:47:48 EDT 2019

Committee Statement

Committee Statement: Determination of freezing is no longer dependent on the isothermal map.

Response Message: FR-39-NFPA 24-2019



First Revision No. 46-NFPA 24-2019 [Section No. A.11.1]

A.11.2

When calculating the actual inside diameter of cement mortar-lined pipe, twice the thickness of the pipe wall and twice the thickness of the lining need to be subtracted from the outside diameter of the pipe. The actual lining thickness should be obtained from the manufacturer.

Table A.11.2(a) and Table A.11.2(b) indicate the minimum lining thickness.

Table A.11.2(a) Minimum Thickness of Lining for Ductile-Iron Pipe and Fittings

Pipe and Fitting Size		-	Thickness of Lining	
in.	mm	-	in.	mm
3-12	80-300	-	$\frac{1}{16}$	1.6
14-24	350-600	-	$\frac{3}{32}$	2
30-64	750-1600	-	$\frac{1}{8}$	3

Source : AWWA C104/A21.4, *Cement Mortar Lining for Ductile-Iron Pipe and Fittings* .

Table A.11.2(b) Minimum Thickness of Lining for Steel Pipe

Nominal Pipe Size		-	Thickness of Lining		-	Tolerance	
in.	mm	-	in.	mm	-	in.	mm
4-10	100-250	-	$\frac{1}{4}$	6	-	$-\frac{1}{16}, +\frac{1}{8}$	-1.6, +3
12-20	300-500	-	$\frac{5}{16}$	8	-	$-\frac{1}{16}, +\frac{1}{8}$	-1.6, +3
24-36	600-900	-	$\frac{3}{8}$	10	-	$-\frac{1}{16}, +\frac{1}{8}$	-1.6, +3
>36	>900	-	$\frac{1}{2}$	13	-	$-\frac{1}{16}, +\frac{3}{16}$	-1.6, +5

Source : AWWA C105/A21.5, *Polyethylene Encasement for Ductile-Iron Pipe Systems* .

Submitter Information Verification

Committee: AUT-PRI

Submission Date: Wed Aug 28 15:49:00 EDT 2019

Committee Statement

Committee Statement: Annex section is deleted since new requirement refers to hydraulic calculation procedures in NFPA 13.

Response Message: FR-46-NFPA 24-2019



First Revision No. 47-NFPA 24-2019 [Section No. E.3]

E.3 References for Extracts in Informational Sections.

NFPA 13, *Standard for the Installation of Sprinkler Systems*, 2019 2022 edition.

NFPA 291, *Recommended Practice for Fire Flow Testing and Marking of Hydrants*, 2019 2022 edition.

Submitter Information Verification

Committee: AUT-PRI

Submittal Date: Tue Sep 24 10:31:02 EDT 2019

Committee Statement

Committee Statement: Updates to current edition.

Response Message: FR-47-NFPA 24-2019